

**SUZUKI**

**SQ420WD**

**SERVICE MANUAL**

**SUZUKI**  
Caring for Customers

99500-68D00-01E

(英)

# IMPORTANT

## WARNING/CAUTION/NOTE

Please read this manual and follow its instructions carefully. To emphasize special information, the words **WARNING**, **CAUTION** and **NOTE** have special meanings. Pay special attention to the messages highlighted by these signal words.

### WARNING:

Indicates a potential hazard that could result in death or injury.

### CAUTION:

Indicates a potential hazard that could result in vehicle damage.

### NOTE:

Indicates special information to make maintenance easier or instructions clearer.

### WARNING:

This service manual is intended for authorized SUZUKI dealers and qualified service mechanics only. Inexperienced mechanics or mechanics without the proper tools and equipment may not be able to properly perform the services described in this manual. Improper repair may result in injury to the mechanic and may render the vehicle unsafe for the driver and passengers.

### WARNING:

For vehicles equipped with a Supplemental Restraint (Air Bag) System:

- Service on and around the air bag system components or wiring must be performed only by an authorized SUZUKI dealer. Refer to "Air Bag System Components and Wiring Location View" under "General Description" in air bag system section in order to confirm whether you are performing service on or near the air bag system components or wiring. Please observe all **WARNINGS** and "Service Precautions" under "On-Vehicle Service" in air bag system section before performing service on or around the air bag system components or wiring. Failure to follow **WARNINGS** could result in unintentional activation of the system or could render the system inoperative. Either of these two conditions may result in severe injury.
- If the air bag system and another vehicle system both need repair, SUZUKI recommends that the air bag system be repaired first, to help avoid unintended air bag system activation.
- Do not modify the steering wheel, instrument panel or any other air bag system component (on or around air bag system components or wiring). Modifications can adversely affect air bag system performance and lead to injury.
- If the vehicle will be exposed to temperatures over 93°C (200°F) (for example, during a paint baking process), remove the air bag system components (air bag (inflator) module, sensing and diagnostic module (SDM), seat belt pretensioner (if equipped) beforehand to avoid component damage or unintended activation.

## FOREWORD

This SERVICE MANUAL is a supplement to SQ416/SQ420/SQ625 SERVICE MANUAL (SERVICE MANUAL 99500-65D00, UNIT REPAIR MANUAL 99501-65D00) and SQ416/SQ420/SQ625 WIRING DIAGRAM MANUAL (99512-65D00-015)

### Applicable model: SQ420WD

It described only different servicing information of SQ420WD as compared with SQ416/SQ420/SQ625.

Therefore, whenever servicing SQ420WD, consult this service manual first.

And for any section, item or description not found in this service manual, refer to the above mentioned manuals.

When replacing parts or servicing by disassembling, it is recommended to use SUZUKI genuine parts, tools and service materials (lubricant, sealants, etc.) as specified in each description.

All information, illustrations and specifications contained in this literature are based on the latest product information available at the time of publication approval. And used as the main subject of description is the vehicle of standard specifications among others.

Therefore, note that illustrations may differ from the vehicle being actually serviced.

The right is reserved to make changes at any time without notice.

### RELATED MANUALS:

Manual Name	Manual No.
SQ416/SQ420/SQ625 Service Manual (Volume 1 and 2)	99500-65D00
SQ416/SQ420/SQ625 Unit Repair Manual ( For Manual Transmission, Automatic Transmission, Transfer and Differential.)	99501-65D00
SQ416/SQ420/SQ625 Wiring Diagram Manual	99512-65D00-015

**SUZUKI MOTOR CORPORATION**

OVERSEAS SERVICE DEPARTMENT

TABLE OF CONTENTS	SECTION
<b>GENERAL INFORMATION</b>	
General Information	0A
Maintenance and Lubrication	0B
<b>HEATING AND AIR CONDITIONING</b>	
Air Conditioning	1B
<b>STEERING, SUSPENSION, WHEELS AND TIRES</b>	
Power Steering (P/S) System	3B1
<b>DRIVE SHAFT/PROPELLER SHAFT</b>	
Front Drive Shaft/Shaft Bearing, Oil Seal	4A2
<b>ENGINE</b>	
General Information and Diagnosis	6
Engine Mechanical (RF)	6A3
Engine Cooling	6B
Engine Fuel	6C
Engine and Emission Control System (Electronically-controlled Diesel Fuel Injection System)	6E3
Cranking System (2.2 kw Reduction Type)	6G
Charging System	6H
Exhaust System	6K
<b>TRANSMISSION, CLUTCH AND DIFFERENTIAL</b>	
Automatic Transmission	7B1
Clutch (Hydraulic Type)	7C1
Differential (Rear)	7F
<b>BODY ELECTRICAL SYSTEM</b>	
Instrumentation/Driver Information	8C
Immobilizer Control System	8G
<b>SERVICE DATA</b>	10

0A
0B
1B
3B1
4A2
6
6A3
6B
6C
6E3
6G
6H
6K
7B1
7C1
7F
8C
8G
10

TABLE OF CONTENTS	SECTION
Wiring Diagram	8A

8A
----

## SECTION 0A

# GENERAL INFORMATION

**NOTE:**

For the descriptions (items) not found in this section, refer to the same section of the Service Manual mentioned in FOREWORD of this manual.

## CONTENTS

<b>IDENTIFICATION INFORMATION</b> .....	0A-1
Engine Identification Number .....	0A-1

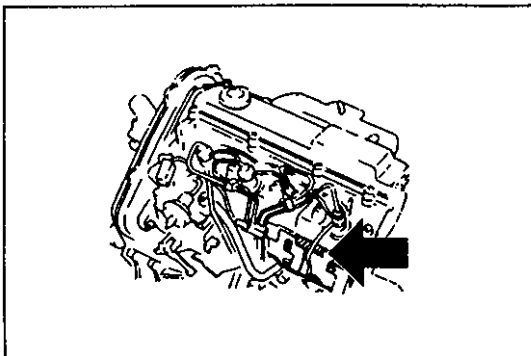

## IDENTIFICATION INFORMATION

### ENGINE IDENTIFICATION NUMBER

The number is punched on the cylinder block.

## SECTION 0B

# MAINTENANCE AND LUBRICATION

**WARNING:**

For vehicles equipped with Supplemental Restraint (Air Bag) System:

- Service on and around the air bag system components or wiring must be performed only by an authorized SUZUKI dealer. Refer to “Air Bag System Components and Wiring Location View” under “General Description” in air bag system section in order to confirm whether you are performing service on or near the air bag system components or wiring. Please observe all WARNINGS and “Service Precautions” under “On-Vehicle Service” in air bag system section before performing service on or around the air bag system components or wiring. Failure to follow WARNINGS could result in unintentional activation of the system or could render the system inoperative. Either of these two conditions may result in severe injury.
- Technical service work must be started at least 90 seconds after the ignition switch is turned to the “LOCK” position and the negative cable is disconnected from the battery. Otherwise, the system may be activated by reserve energy in the Sensing and Diagnostic Module (SDM).

**NOTE:**

For the descriptions (items) not found in this section, refer to the same section of the Service Manual mentioned in FOREWORD of this manual.

## CONTENTS

<b>MAINTENANCE SCHEDULE</b> .....	0B- 2
Maintenance Schedule under Normal Driving Conditions .....	0B- 2
Maintenance Recommended under Severe Driving Conditions .....	0B- 3
<b>MAINTENANCE SERVICE</b> .....	0B- 4
Engine .....	0B- 4
Fuel System .....	0B-10
Electrical System .....	0B-11
<b>RECOMMENDED FLUIDS AND LUBRICANTS</b> .....	0B-11

## MAINTENANCE SCHEDULE

### MAINTENANCE SCHEDULE UNDER NORMAL DRIVING CONDITIONS

Interval: This interval should be judged by odometer reading or months, whichever comes first.	This table includes services as scheduled up to 80,000 km (48,000 miles) mileage. Beyond 80,000 km (48,000 miles), carry out the same services at the same intervals respectively.									
	km (x 1,000)	1	10	20	30	40	50	60	70	80
	miles (x 1,000)	0.6	6	12	18	24	30	36	42	48
	Months	-	6	12	18	24	30	36	42	48
<b>1. ENGINE</b>										
1-1. Drive belt										
1-2. Camshaft timing belt	Replace every 100,000 km or 60,000 miles									
1-3. Valve lash (clearance)	-	-	-		-	-		-	-	-
1-4. Engine oil and oil filter	Replace every 10,000 km or 6,000 miles									
1-5. Engine coolant	-	-	-	-	R	-	-	-	-	R
1-6. Cooling system hoses and connections	-	-		-		-		-	-	
1-7. Exhaust pipes and mountings (except catalyst)	-	-	-	-		-	-	-	-	I&(R)
<b>3. FUEL SYSTEM</b>										
3-1. Air cleaner filter element					R					R
3-2. Fuel tank cap, fuel lines and connections	-	-	-	-		-	-	-	-	I&(R)
3-3. Fuel filter	Replace every 100,000 km or 60,000 miles									
<b>5. ELECTRICAL SYSTEM</b>										
5-1. Wiring harness and connections	-	-	-	-		-	-	-	-	

**NOTE:**

**"R": Replace or change**

**"I": Inspect and correct, replace or lubricate if necessary**

• Item 1-7 (R) is applicable to exhaust mounting rubber only.

• Item 3-2 (R) is applicable to fuel tank cap only.

**NOTE:**

For Item 6. Chassis and Body, refer to the same section of the Service Manual mentioned in FOREWORD of this manual.

## MAINTENANCE RECOMMENDED UNDER SEVERE DRIVING CONDITIONS

If the vehicle is usually used under the conditions corresponding to any severe condition code given below, it is recommended that applicable maintenance operation be performed at the particular interval as given in the chart below.

### Severe condition code

- A – Towing a trailer
- E – Driving in extremely cold weather and/or salted roads
- B – Repeated short trips
- F – Repeated short trips in extremely cold weather
- C – Driving on rough and/or muddy roads
- D – Driving on dusty roads

Severe Condition Code	Maintenance	Maintenance Operation	Maintenance Interval
— — C D — —	Water pump (fan) drive belt	I	Every 12,000 miles (20,000 km) or 12 months
		R	Every 24,000 miles (40,000 km) or 24 months
A B — D E F	Engine oil and oil filter	R	Every 3,000 miles (5,000 km) or 3 months For diesel engine, replace more often.
A B C — E —	Exhaust pipes and mountings	I	Every 6,000 miles (10,000 km) or 6 months
— — — D — —	Air cleaner filter element *1	I	Every 1,500 miles (2,500 km)
		R	Every 12,000 miles (20,000 km) or 12 months
A B C D — —	Brake discs and pads (Front) Brake drums and shoes (Rear)	I	Every 6,000 miles (10,000 km) or 6 months
A B C — E —	Propeller shafts	I	Every 6,000 miles (10,000 km) or 6 months
A — C — — F	Manual transmission, transfer and differential oil	R	Every 12,000 miles (20,000 km) or 12 months
A — C — — F	Automatic transmission fluid	R	Every 12,000 miles (20,000 km) or 12 months
— — C — — —	Drive axle shaft boots	I	Every 6,000 miles (10,000 km) or 6 months
— — C — — —	Bolts and nuts on chassis (suspension)	T	Every 6,000 miles (10,000 km) or 6 months
— — — D E —	Air conditioning filter element *2 (if equipped)	I	Every 6,000 miles (10,000 km) or 6 months
		R	Every 24,000 miles (40,000 km) or 24 months

**NOTE:**

**"I" : Inspect and correct, replace or lubricate if necessary**

**"R": Replace or change**

**"T": Tighten to the specified torque**

- \*1: Inspect or replace more frequently if the vehicle is used under dusty conditions.
- \*2: Clean more frequently if the air flow from air conditioning decreases.

# MAINTENANCE SERVICE

## ENGINE

### ITEM 1-1

#### Drive Belt Inspection and Replacement

##### WARNING:

All inspection and replacement are to be performed with ENGINE NOT RUNNING.

#### Fan belt

##### Inspection

- 1) Disconnect negative cable at battery.
- 2) Inspect belt for cracks, cuts, deformation, wear and cleanliness. If any defect exists, replace.  
Check belt for tension under thumb pressure (about 10 kg or 22 lb.).

##### Belt Tension:

15 — 17 mm (0.59 — 0.67 in.) as deflection (when inspection)

15 — 16 mm (0.59 — 0.63 in.) as deflection (when adjustment)

##### NOTE:

When replacing belt with a new one, adjust belt tension to 8 — 10 mm (0.31 — 0.39 in.).

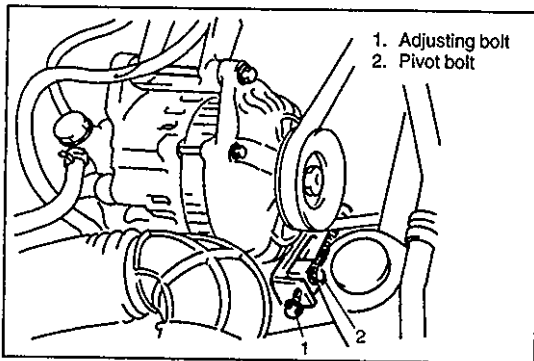
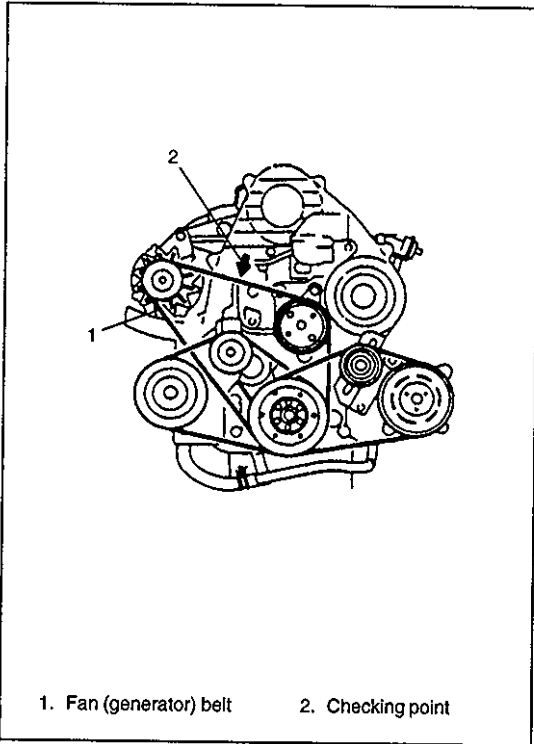

- 3) If belt is too tight or too loose, adjust it to specification by adjusting alternator position.
- 4) Tighten alternator adjusting bolt and pivot bolts.
- 5) Connect negative cable to battery.

#### Replacement

Replace belt. Refer to Section 6B for replacement procedure of pump belt.

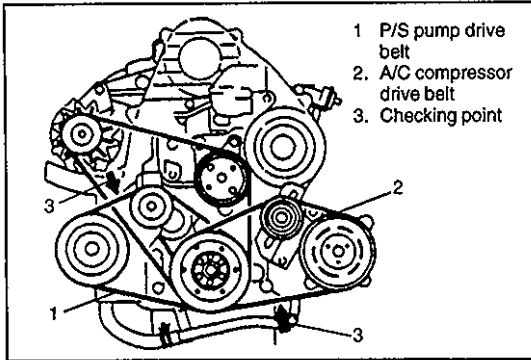

**A/C Compressor and/or Power Steering Pump Drive Belt (If equipped)**

Inspect belt for wear, deterioration and tension.

**Belt Tension:**

For A/C compressor drive belt : 8 — 10 mm (0.31 — 0.39 in.) deflection under 10 kg or 22 lb pressure

For Power steering pump drive belt : 6 — 7 mm (0.24 — 0.27 in.) deflection under (10 kg, 22 lb) pressure

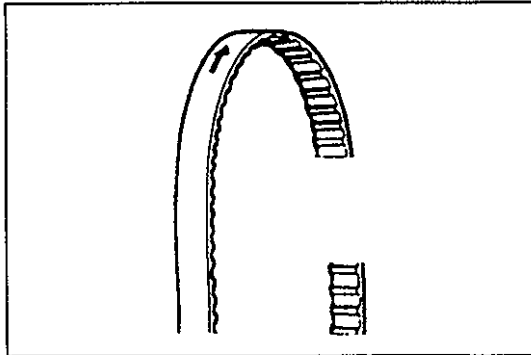

**ITEM 1-2**

**Camshaft Timing Belt Replacement**

Replace timing belt referring to SECTION 6A3.

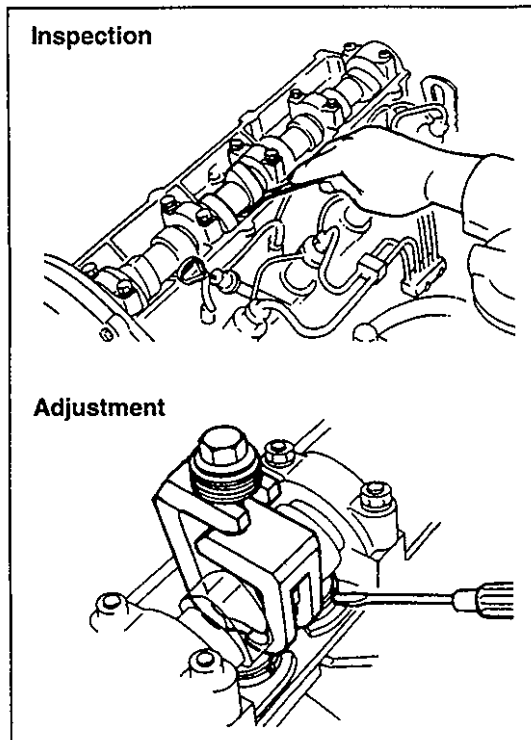

**ITEM 1-3**

**Valve Lash Inspection**

Inspect intake and exhaust valve lash and adjust as necessary referring to SECTION 6A3.

**ITEM 1-4**

**Engine Oil and Oil Filter Change**

Before draining engine oil, check engine for oil leakage. If any evidence of leakage is found, make sure to correct defective part before proceeding to the following work.

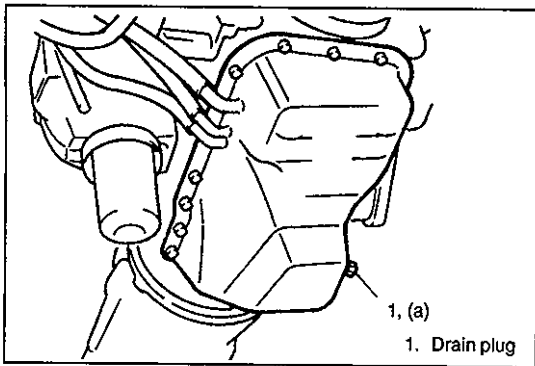

- 1) Drain engine oil by removing drain plug.
- 2) After draining oil, wipe drain plug clean. Reinstall drain plug, and tighten it securely as specified below.

**Tightening Torque**

(a): 35 N·m (3.5 kg-m, 25.5 lb-ft)

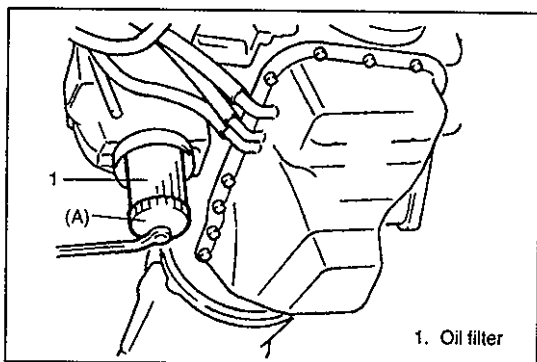

- 3) Loosen oil filter by using oil filter wrench (special tool).

**Special Tool**

(A): 09915-47810

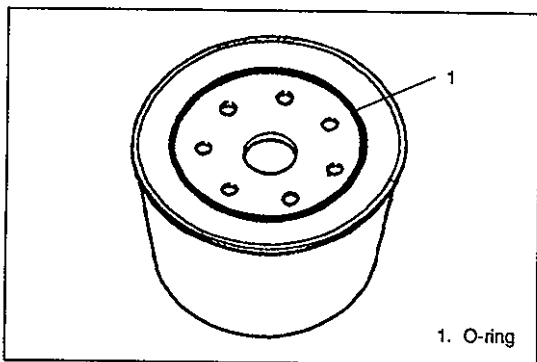

- 4) Apply engine oil to oil filter O-ring.

- 5) Screw new filter on oil filter stand by hand until filter O-ring contacts mounting surface.

**CAUTION:**

To tighten oil filter properly, it is important to accurately identify the position at which filter O-ring first contacts mounting surface.

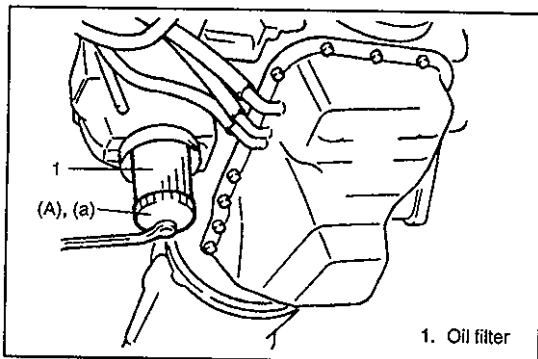

- 6) Tighten filter 7/6 turn from the point of contact with mounting surface using an oil filter wrench.

**Special Tool**

(A): 09915-47810

**Tightening Torque**

(a): 23 N·m (2.3 kg-m, 17 lb-ft)

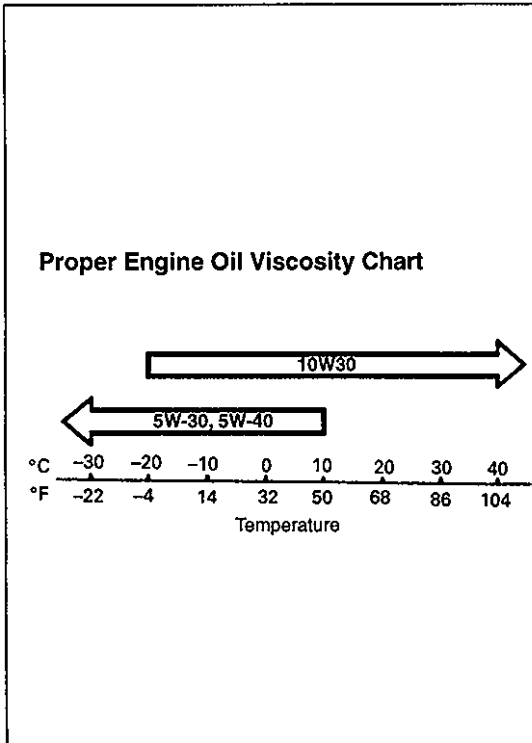

7) Replenish oil until oil level is brought to FULL level mark on dipstick. (about 5.5 liters or 11.6/9.7 US/Imp pt.). Filler inlet is atop the cylinder head cover.

It is recommended to use engine oil of CD, CE or CF-4 class. Select the appropriate oil viscosity according to the chart at the left.

**Engine oil capacity**

Oil pan capacity	About 5.0 liters (10.6/8.8 US/Imp pt.)
Oil filter capacity	About 0.5 liters (1.1/0.9 US/Imp pt.)

**NOTE:**

Engine oil capacity is specified as above.

However, note that amount of oil required when actually changing oil may somewhat differ from the data in above table depending on various conditions (temperature, viscosity, etc.).

8) Start engine and run it for three minutes. Stop it and wait another three minutes before checking oil level. Add oil, as necessary, to bring oil level to FULL level mark on dipstick.

**NOTE:**

Steps 1) – 7) outlined above must be performed with **ENGINE NOT RUNNING**. For step 8), be sure to have adequate ventilation while engine is running.

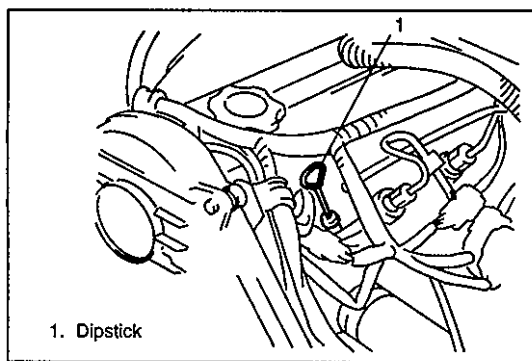

**ITEM 1-5**

**Engine Coolant Change**

**WARNING:**

To help avoid danger of being burned, do not remove radiator cap while engine and radiator are still hot. Scalding fluid and steam can be blown out under pressure if cap is taken off too soon.

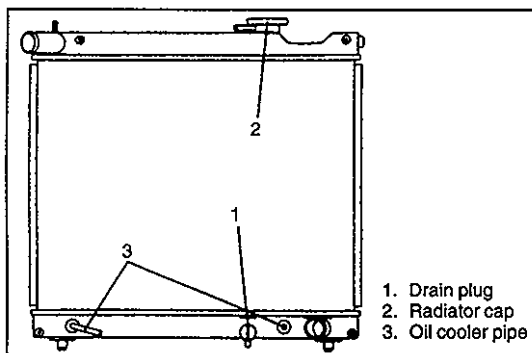

- 1) Remove radiator cap when engine is cool.
- 2) Loosen radiator drain plug to drain coolant.
- 3) Remove reservoir tank, which is on the side of radiator, and drain.
- 4) Tighten plug securely. Also reinstall reservoir tank.

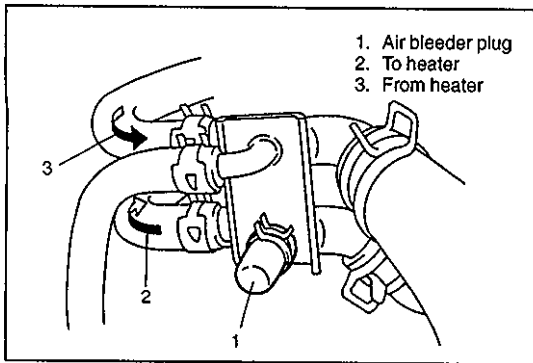

- 5) Fill up radiator with coolant and bleed air by removing air bleeder plugs while cool engine running.

**CAUTION:**

Failure to bleed air causes engine overheat.

**NOTE:**

Connect proper hoses to air bleeder pipe and reservoir tank to prevent coolant from spilling out.

- 6) After bleeding air from bleeder pipes, connect bleeder plugs and clamp them securely.
- 7) Add coolant as necessary until coolant level reaches the filler throat of radiator. Reinstall radiator cap.

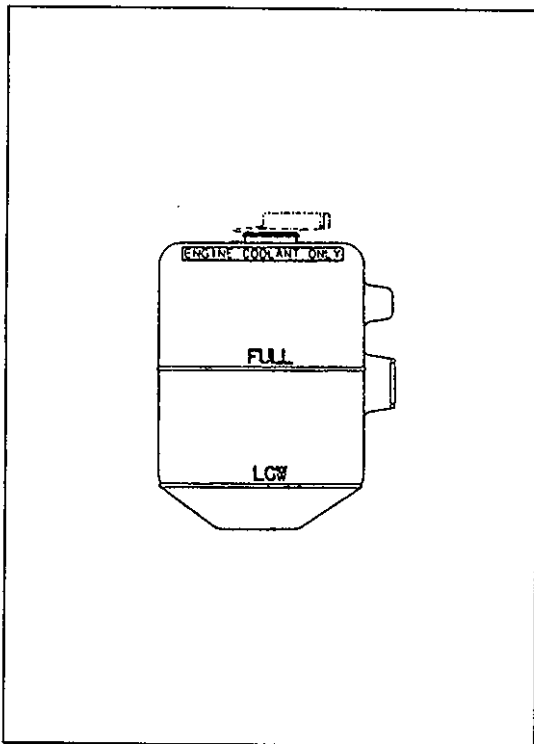

- 8) Add coolant to reservoir tank so that its level aligns with Full mark. Then, reinstall cap aligning arrow marks on the tank and cap.

**NOTE:**

When installing reservoir tank cap, align arrow marks on the tank and cap.

**CAUTION:**

When changing engine coolant, use mixture of 50% water and 50% ANTIFREEZE/ANTICORROSION COOLANT for the market where ambient temperature falls lower than  $-16^{\circ}\text{C}$  ( $3^{\circ}\text{F}$ ) in winter, and mixture of 70% water and 30% ANTIFREEZE/ANTICORROSION COOLANT for the market where ambient temperature doesn't fall lower than  $-16^{\circ}\text{C}$  ( $3^{\circ}\text{F}$ ).

Even in a market where no freezing temperature is anticipated, mixture of 70% water and 30% ANTIFREEZE/ANTICORROSION COOLANT should be used for the purpose of corrosion protection and lubrication.

**ITEM 1-6****Cooling System Hoses and Connections****Inspection**

- 1) Visually inspect cooling system hoses for any evidence of leakage and cracks. Examine them for damage, and check connection clamps for tightness.
- 2) Replace all hoses which show evidence of leakage, cracks or other damage. Replace all clamps which cannot maintain proper tightness.

**ITEM 1-7****Exhaust Pipes and Mountings****Inspection****WARNING:**

**To avoid danger of being burned, do not touch exhaust system when it is still hot.**

**Any service on exhaust system should be performed when it is cool.**

When carrying out periodic maintenance, or the vehicle is raised for other service, check exhaust system as follows:

- Check rubber mountings for damage, deterioration, and out of position.
- Check exhaust system for leakage, loose connections, dents, and damages.

If bolts or nuts are loose, tighten them to specification.

Refer to SECTION 6A3 for torque specification of bolts and nuts.

- Check nearby body areas for damaged, missing, or mispositioned parts, open seams, holes, loose connections or other defects which could permit exhaust fumes to seep into vehicle.
- Make sure that exhaust system components have enough clearance from underbody to avoid overheating and possible damage to floor or carpet.
- Any defects should be fixed at once.

**Mounting replacement**

Replace muffler rubber mountings with new ones periodically. Refer to Section 6K for installation.

## FUEL SYSTEM

### ITEM 3-1

#### Air Cleaner Filter Element

##### Inspection and cleaning

- 1) Remove air cleaner case clamps.
- 2) Take cleaner element out of air cleaner case.
- 3) Check air cleaner element for dirt. Replace excessively dirty element.
- 4) Blow off dust by compressed air from air outlet side of element.
- 5) Install air cleaner element into case.
- 6) Install air cleaner case cap and clamp it securely.

##### Replacement

Replace air cleaner element with new one according to above steps 1), 2) and 5), 6).

### ITEM 3-2

#### Fuel tank Cap, Fuel Lines and Connections

##### Inspection

- 1) Visually inspect fuel lines and connections for evidence of fuel leakage, hose cracking and damage. Make sure all clamps are secure.  
Repair leaky joints, if any.  
Replace hoses that are suspected of being cracked.

- 2) Visually inspect gasket of fuel tank cap. If it is damaged or deteriorated, replace it with new one.

##### Fuel tank cap replacement

Replace tank cap with new one periodically.

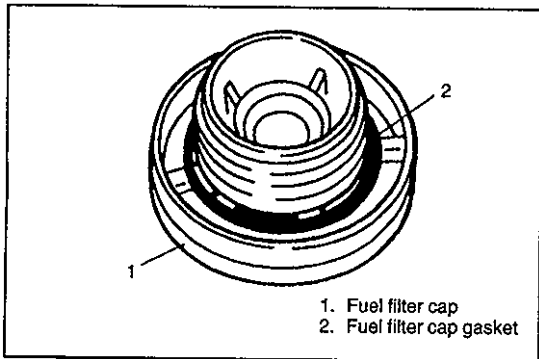
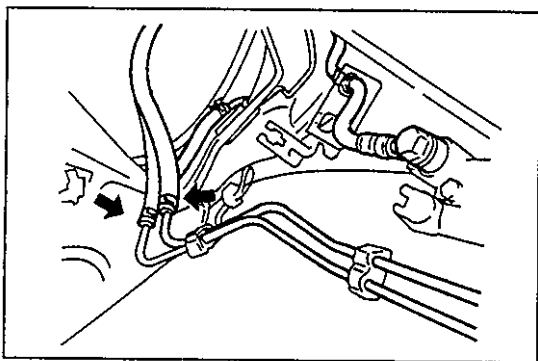
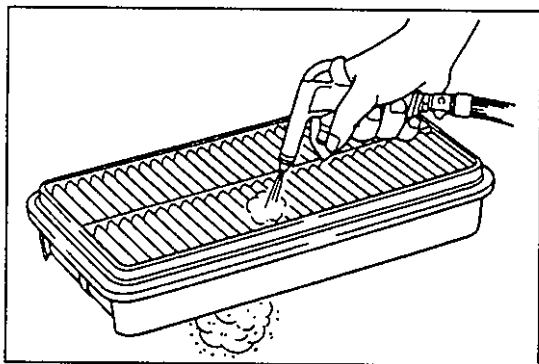
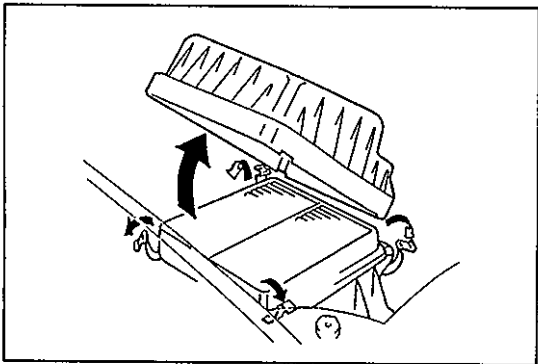

**ITEM 3-3**

**Fuel Filter Replacement**

**WARNING:**

**This work must be performed in a well ventilated area and away from any open flames (such as gas hot water heaters).**

Fuel filter is located at the left side of strut tower bar.

Replace fuel filter with new one periodically, referring to Section 6C for proper procedure.

**ELECTRICAL SYSTEM**

**ITEM 5-1**

**Wiring Harness and Connections Inspection**

- 1) Visually inspect all wires in engine compartment for evidence of breakage.  
Inspect condition of insulation (cracks). All clips and clamps should have solid connection to wires.
- 2) Replace any wires in a deteriorated or otherwise defective condition.

**RECOMMENDED FLUIDS AND LUBRICANTS**

Engine oil	CD, CE or CF-4 class (Refer to engine oil viscosity chart in item 1-4)
Engine coolant (Ethylene glycolbase coolant)	"Antifreeze/Anticorrosion coolant"
Brake fluid	Specified fluid indicated on reservoir tank cap
Manual transmission oil	Refer to Section 7A1.
Transfer oil	
Differential oil (front & rear)	Refer to Section 7E or 7F.
Automatic transmission fluid and Power steering fluid	An equivalent of DEXRON®-II or DEXRON®-III
Clutch linkage pivot points	Water resistance chassis grease (SUZUKI SUPER GREASE A 99000-25010)
Door hinges	Engine oil or water resistance chassis grease
Hood latch assembly	
Key lock cylinder	Spray lubricant

## SECTION 1B

## AIR CONDITIONING (OPTIONAL)

1B

**WARNING:**

For vehicles equipped with Supplemental Restraint (Air Bag) System:

- Service on and around the air bag system components or wiring must be performed only by an authorized SUZUKI dealer. Refer to "Air Bag System Components and Wiring Location View" under "General Description" in air bag system section in order to confirm whether you are performing service on or near the air bag system components or wiring. Please observe all WARNINGS and "Service Precautions" under "On-Vehicle Service" in air bag system section before performing service on or around the air bag system components or wiring. Failure to follow WARNINGS could result in unintentional activation of the system or could render the system inoperative. Either of these two conditions may result in severe injury.
- Technical service work must be started at least 90 seconds after the ignition switch is turned to the "LOCK" position and the negative cable is disconnected from the battery. Otherwise, the system may be activated by reserve energy in the Sensing and Diagnostic Module (SDM).

**CAUTION:**

The air conditioning system of this vehicle uses refrigerant HFC-134a (R-134a).

None of refrigerant, compressor oil and component parts is interchangeable between two types of A/C: one using refrigerant CFC-12 (R-12) and the other using refrigerant HFC-134a (R-134a).

Be sure to check which refrigerant is used before any service work including inspection and maintenance. For identification between these two types, refer to the same section of the Service Manual mentioned in FOREWORD of this manual.

When replenishing or changing refrigerant and compressor oil and when replacing parts, make sure that the material or the part to be used is appropriate to the A/C installed in the vehicle being serviced. Use of incorrect one will result in leakage of refrigerant, damage in parts or other faulty condition.

**NOTE:**

For the descriptions (items) not found in this section, refer to the same section of the Service Manual mentioned in FOREWORD of this manual.

## CONTENTS

<b>GENERAL DESCRIPTION</b> .....	1B- 2
Component Location in Engine Room .....	1B- 2
<b>WIRING CIRCUIT</b> .....	1B- 3
<b>ON-VEHICLE SERVICE</b> .....	1B- 4
Compression System .....	1B- 4

## GENERAL DESCRIPTION

### COMPONENT LOCATION IN ENGINE ROOM

RF LH steering vehicle

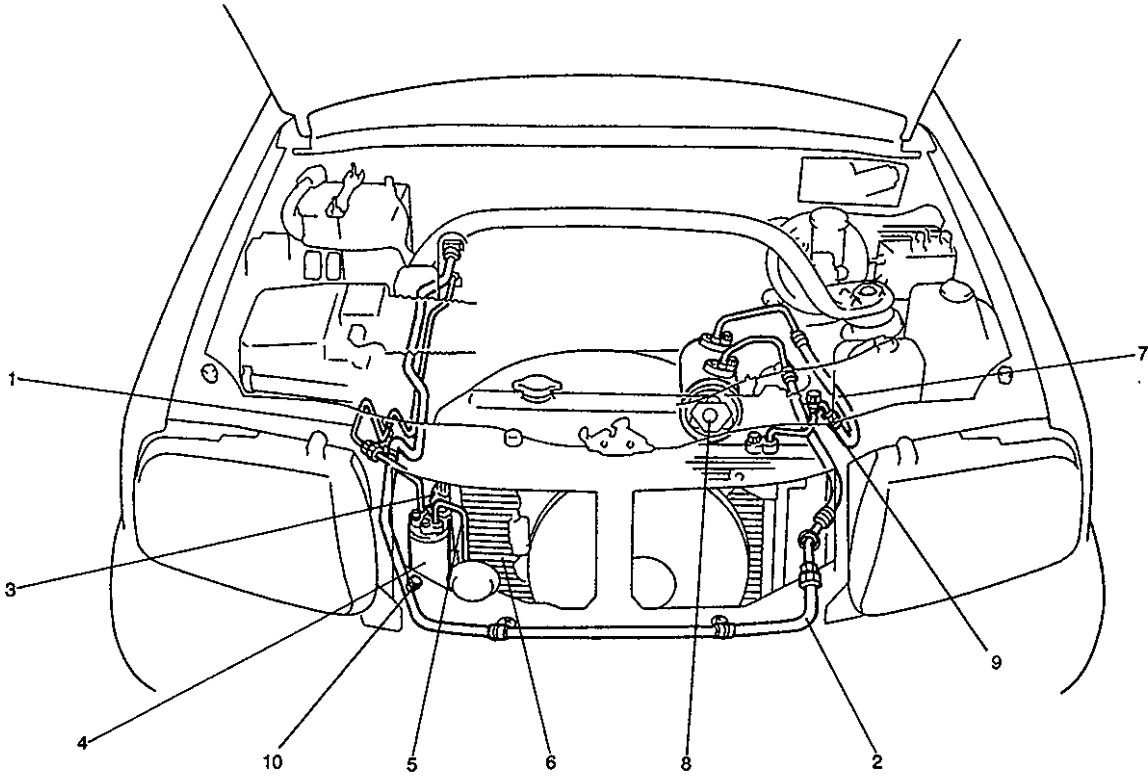

1. Receiver/Dryer outlet pipe
2. Compressor suction hose/pipe
3. Dual pressure switch
4. Receiver/Dryer
5. Condenser outlet pipe
6. Condenser
7. Compressor delivery hose
8. Compressor
9. High pressure service valve
10. Low pressure service valve

# WIRING CIRCUIT

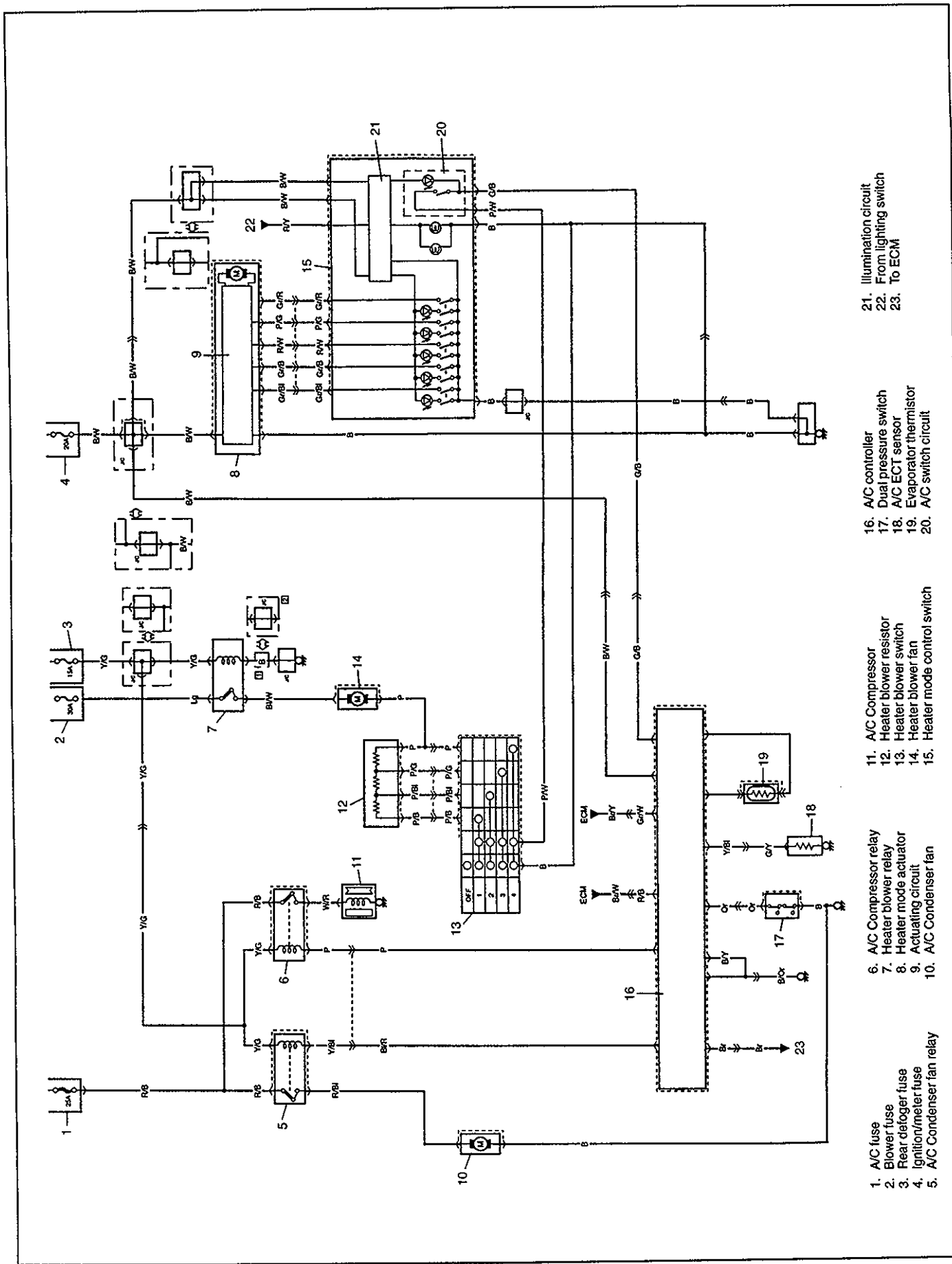

- 1. A/C fuse
- 2. Blower fuse
- 3. Rear defogger fuse
- 4. Ignition/meter fuse
- 5. A/C Condenser fan relay
- 6. A/C Compressor relay
- 7. Heater blower relay
- 8. Heater mode actuator
- 9. Actuating circuit
- 10. A/C Condenser fan
- 11. A/C Compressor
- 12. Heater blower resistor
- 13. Heater blower switch
- 14. Heater mode fan
- 15. Heater mode control switch
- 16. A/C controller
- 17. Dual pressure switch
- 18. A/C ECT sensor
- 19. Evaporator thermistor
- 20. A/C switch circuit
- 21. Illumination circuit
- 22. From lighting switch
- 23. To ECM

LH Steering vehicle shown

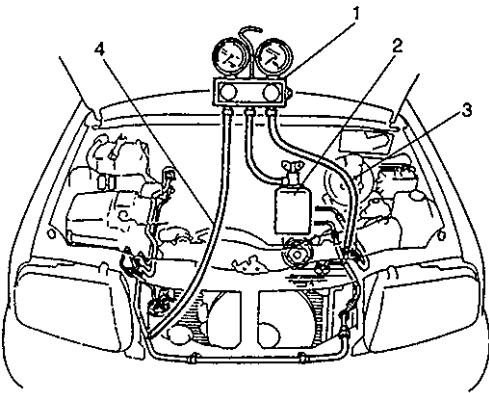

1. Manifold gauge set
2. Refrigerant container
3. High pressure side (Delivery side hose)
4. Low pressure side (Suction side hose)

## ON-VEHICLE SERVICE

### COMPRESSION SYSTEM

#### COMPRESSOR

##### INSPECTION

- 1) Install manifold gauge set as illustrated.
- 2) Close Hi and Lo hand valves.
- 3) Run engine at fast idle.
- 4) Check compressor for following:
  - a. High pressure gauge reading is not low and low pressure gauge reading is not higher than normal.
  - b. Metallic sound.
  - c. Leakage from shaft seal.

If any of the above checks indicated a defect, repair compressor.

##### REMOVAL

- 1) Run engine at idle with A/C ON for 10 minutes.
- 2) Disconnect negative cable at battery.
- 3) Recover refrigerant from refrigeration system using recovery and recycling equipment.

##### NOTE:

The amount of compressor oil removed must be measured and the same amount must be poured when installing the compressor.

- 4) Disconnect thermal protector lead wire.
- 5) Disconnect suction and discharge hoses from compressor.

##### NOTE:

Cap open fitting immediately to keep moisture out of system.

- 6) Remove compressor drive belt by loosening tension pulley bolt.
- 7) Remove compressor with clutch assembly from its mount.
- 8) Remove compressor bracket.
- 9) Drain oil from compressor, and measure its amount.

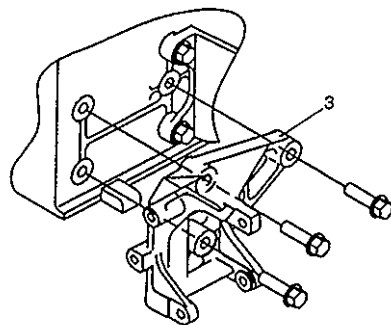
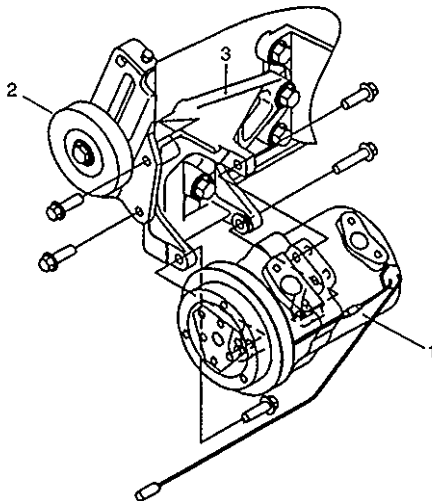

1. A/C compressor
2. Tension pulley
3. Bracket

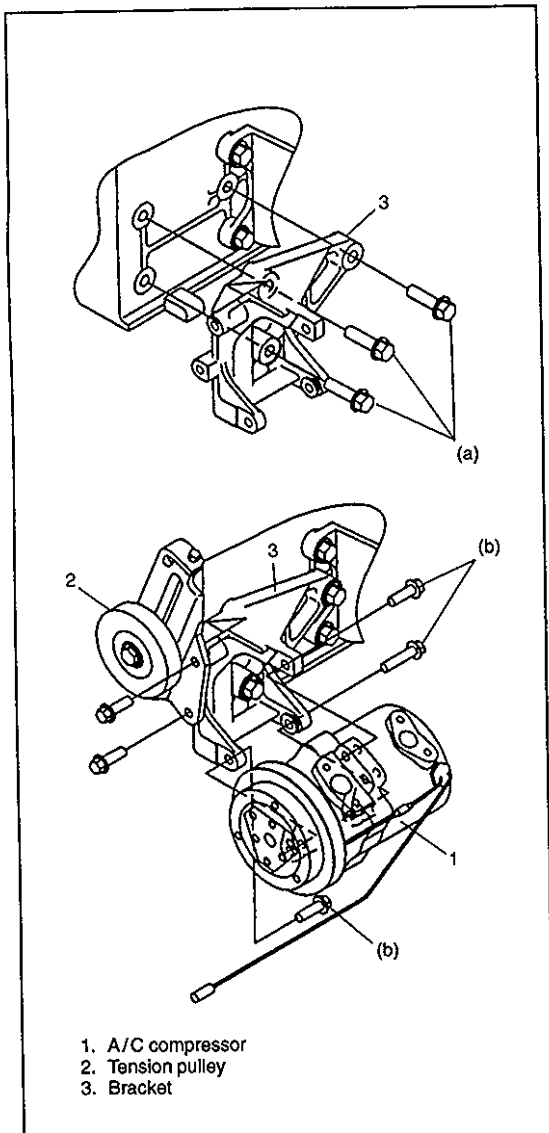

## INSTALLATION

- 1) Pour new compressor oil. The amount must be the same with the amount measured in REMOVAL.

### NOTE:

Compressor assembly supplied from factory is filled up with following amount of oil.

**Amount of oil in compressor: 120 cm<sup>3</sup> (120 cc, 7.5 in<sup>3</sup>)**

- 2) Install compressor bracket to cylinder block.

### Tightening Torque

**(a): 50 N·m (5.0 kg-m, 36.5 lb-ft)**

- 3) Install compressor to its bracket.

### Tightening Torque

**(b): 23 N·m (2.3 kg-m, 17.0 lb-ft)**

- 4) Connect suction and discharge hoses to compressor.
- 5) Install compressor drive belt. Refer to "Inspection" under "Drive belt" later in this section for installation and belt tension.
- 6) Connect thermal protector lead wire.
- 7) Evacuate and charge system according to previously described procedure.

### CAUTION:

**Be sure to use HFC-134a (R-134a) compressor oil.**

## DRIVE BELT

### INSPECTION

- Check that belt is free from any damage and properly fitted in pulley groove.
- Check belt tension by measuring how much it deflects when pushed at intermediate point between pulleys with about 10 kg (22 lb) force.

**Deflection of drive belt: 8 – 10 mm (0.31 – 0.39 in.)**

- 1) To adjust drive belt tension, loosen tension pulley bolts and turn tension pulley adjustment bolt.
- 2) Adjust belt tension to above specification. Then tighten tension pulley bolts to specified torque.

**Tightening Torque for tension pulley nut:**

**50 N·m (5.0 kg-m, 36.5 lb-ft)**

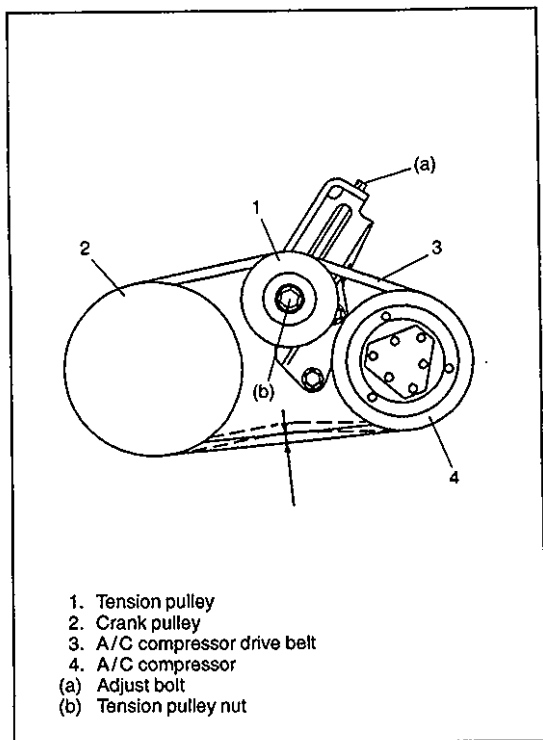

## SECTION 3B1

## POWER STEERING (P/S) SYSTEM

**WARNING:**

For vehicles equipped with Supplemental Restraint (Air Bag) System:

- Service on and around the air bag system components or wiring must be performed only by an authorized SUZUKI dealer. Refer to "Air Bag System Components and Wiring Location View" under "General Description" in air bag system section in order to confirm whether you are performing service on or near the air bag system components or wiring. Please observe all WARNINGS and "Service Precautions" under "On-Vehicle Service" in air bag system section before performing service on or around the air bag system components or wiring. Failure to follow WARNINGS could result in unintentional activation of the system or could render the system inoperative. Either of these two conditions may result in severe injury.
- Technical service work must be started at least 90 seconds after the ignition switch is turned to the "LOCK" position and the negative cable is disconnected from the battery. Otherwise, the system may be activated by reserve energy in the Sensing and Diagnostic Module (SDM).

**NOTE:**

- For the descriptions (items) not found in this section, refer to the same section of the Service Manual mentioned in FOREWORD of this manual.
- Some parts in the Power Steering Gear Box cannot be disassembled or adjusted. For detailed information, refer to the description of POWER STEERING GEAR BOX COMPONENTS under REMOVE AND INSTALL POWER STEERING GEAR BOX.
- All steering gear fasteners are important attaching parts in that they could affect the performance of vital parts and systems, and/or could result in major repair expense. They must be replaced with one of the same part number or with an equivalent part if replacement becomes necessary. Do not use a replacement part of lesser quality or substitute design. Torque values must be used as specified during reassembly to assure proper retention of these parts.

## CONTENTS

<b>DIAGNOSIS</b> .....	3B1-2
Steering Belt Check and Adjustment .....	3B1-2
Fluid Leakage Check .....	3B1-2
Hydraulic Pressure in P/S Circuit Check .....	3B1-3
Air Bleeding Procedure .....	3B1-4
<b>ON-VEHICLE SERVICE</b> .....	3B1-5
Power Steering Pump .....	3B1-5
<b>TIGHTENING TORQUE SPECIFICATIONS</b> .....	3B1-7
<b>REQUIRED SERVICE MATERIALS</b> .....	3B1-7
<b>SPECIAL TOOLS</b> .....	3B1-7

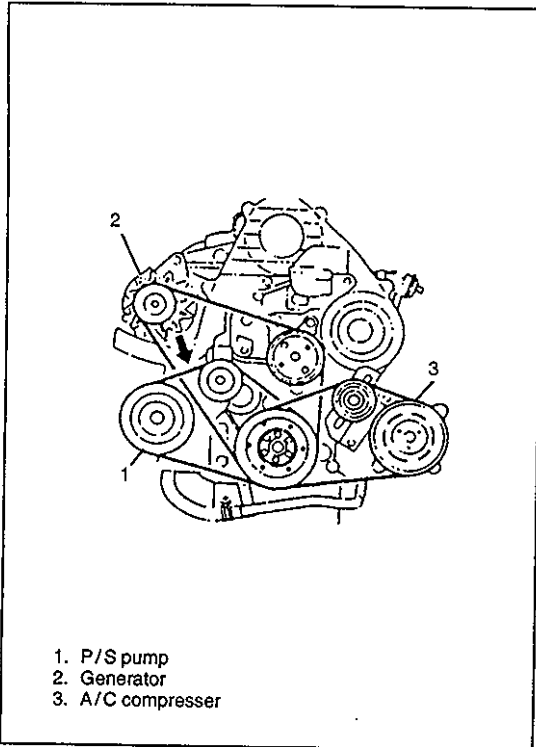

## DIAGNOSIS

### STEERING BELT CHECK AND ADJUSTMENT

- Check that belt is free from any damage and properly fitted in pulley groove.
- Check belt tension by measuring how much it deflects when pushed at intermediate point between pulleys with about 10 kg (22 lb) force.

**Deflection of P/S belt: 6 – 7 mm (0.24 – 0.28 in.)**

- Loosen adjuster bolt, and adjust belt deflection by sliding adjuster.

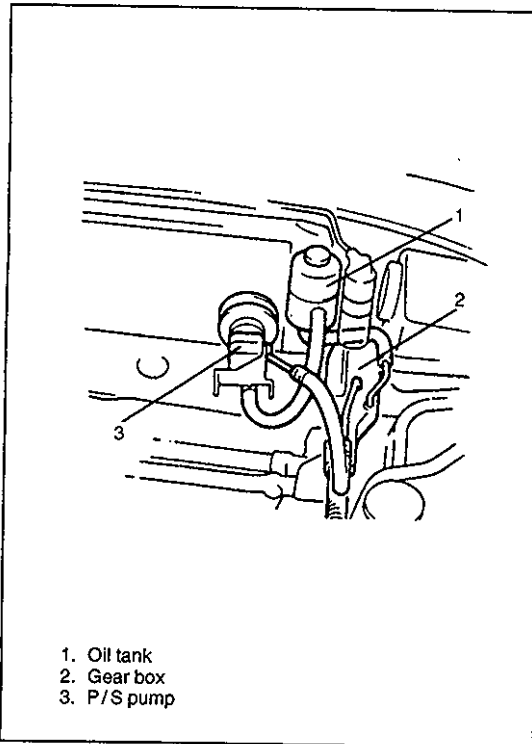

### FLUID LEAKAGE CHECK

Start engine and turn steering wheel fully to the right and left so that maximum hydraulic pressure is provided. Then visually check gear box, P/S pump and oil tank themselves and each joint of their connecting pipes for leakage.

#### CAUTION:

**Never keep steering wheel turned fully for longer than 10 seconds.**

## HYDRAULIC PRESSURE IN P/S CIRCUIT CHECK

- 1) After cleaning joint of high pressure hose and P/S pump thoroughly, disconnect hose from pump and install special tool (oil pressure gauge, attachment and hose). Tighten each flare nut to specified torque.

### CAUTION:

Take care not to cause damage to A/C condenser during service operation, if equipped.

### Special Tool

(A): 09915-77410 (Oil pressure gauge)

(B): 09915-77420

- 2) Check each connection for fluid leakage and bleed air. (Refer to AIR BLEEDING PROCEDURE.)

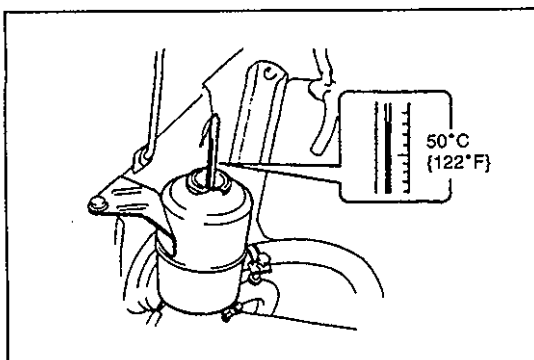
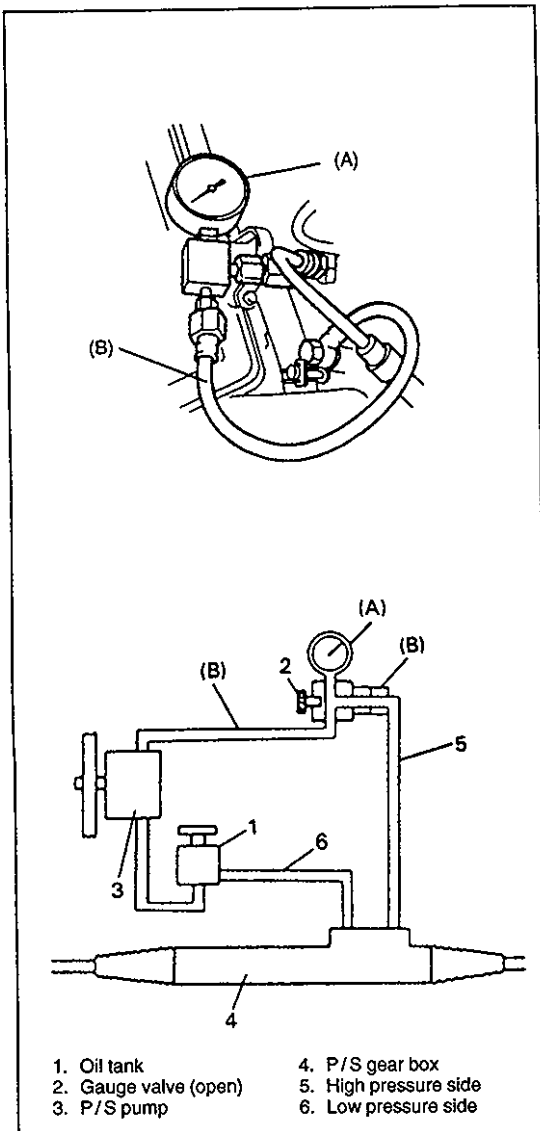

- 3) With engine idling, turn steering wheel and warm up engine till temperature of fluid in tank rises to 50 – 60°C (122 – 140°F).

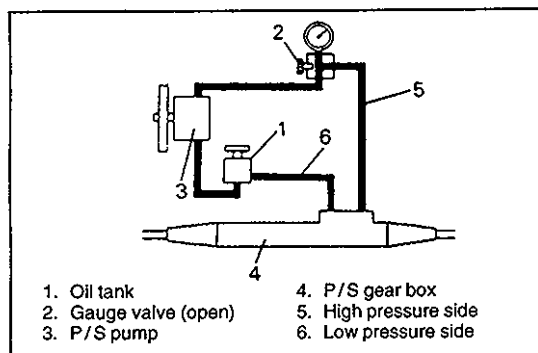

- 4) Check line pressure by measuring hydraulic pressure with engine idling and hands off steering wheel.

**Line pressure: Lower than 1000 kPa (10 kg/cm<sup>2</sup>, 142 psi)**

When line pressure is higher than specified values, check control valve and piping for clogging.

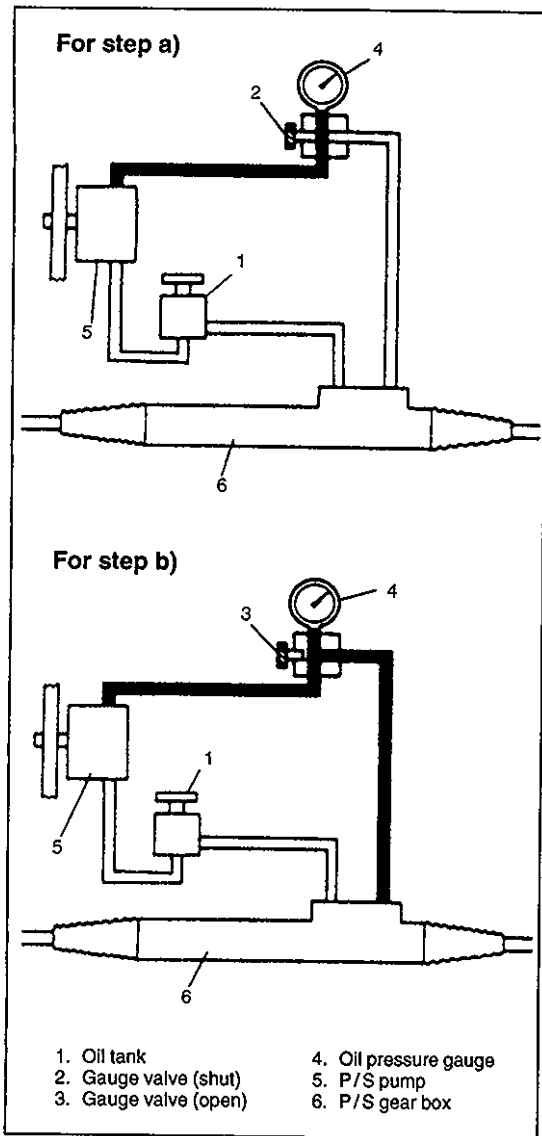

## 5) Check relief pressure

- a) Increase engine speed to about 1,500 r/min (rpm). Close gauge valve gradually while watching pressure increase indicated by gauge and take reading of relief pressure (maximum hydraulic pressure).

**Relief pressure:**

7000 – 8000 kPa (70 – 80 kg/cm<sup>2</sup>, 995 – 1138 psi)

- When it is higher than specified values, possible cause is malfunction of relief valve.
- When it is lower than specified values, possible cause is either failure of P/S pump or settling of relief valve spring.

**CAUTION:**

**Be sure not to close gauge valve for longer than 10 seconds.**

- b) Next, open gauge valve fully and increase engine speed to about 1,500 r/min (rpm). Then turn steering wheel to the left or right fully and take reading of relief pressure.

**Relief pressure:**

7000 – 8000 kPa (70 – 80 kg/cm<sup>2</sup>, 995 – 1138 psi)

- When it is higher than specified values, possible cause is malfunction of relief valve.
- When it is lower than specified values, possible cause is failure in steering gear box. Replace gear box.

**CAUTION:**

**Be sure not to hold steering wheel at fully turned position for longer than 10 seconds.**

## AIR BLEEDING PROCEDURE

- 1) Jack up the front end of vehicle and apply safety stands.
- 2) Fill oil tank with fluid up to specified level.

**NOTE:**

**Before starting engine, place transmission gear shift lever in "Neutral" (shift selector lever to "P" range for A/T model), and set parking brake.**

- 3) After running engine at idling speed for 3 to 5 seconds, stop it and add fluid to satisfy specification.
- 4) With engine stopped, turn steering wheel to the right and left as far as it stops, repeat it a few times and fill fluid to specified level.
- 5) With engine running at idling speed, repeat stop-to-stop turn of steering wheel till all foams in oil tank are gone.

**NOTE:**

**Make sure to bleed air completely. If air remains in fluid, P/S pump may make humming noise or steering wheel may feel heavy.**

- 6) Finally check to make sure that fluid is filled to specified level.

## ON-VEHICLE SERVICE

### POWER STEERING PUMP

#### Removal

- 1) Remove power steering belt.
- 2) Disconnect high pressure hose and low pressure hose.

#### CAUTION:

- Before disconnecting high pressure hose and low pressure hose, clean them completely.
- After power steering pump removal, plug ports to prevent dust and other foreign objects from entering.

- 3) Disconnect pressure switch lead harness.
- 4) Loosen oil pump fixing bolts (3 points).

#### Installation

- 1) Install in reverse order of removal.
- 2) After installation, fill with automatic transmission fluid (DEXRON®-II, DEXRON®-IIE and DEXRON®-III), and Bleed air from system (Refer to AIR BLEEDING PROCEDURE)

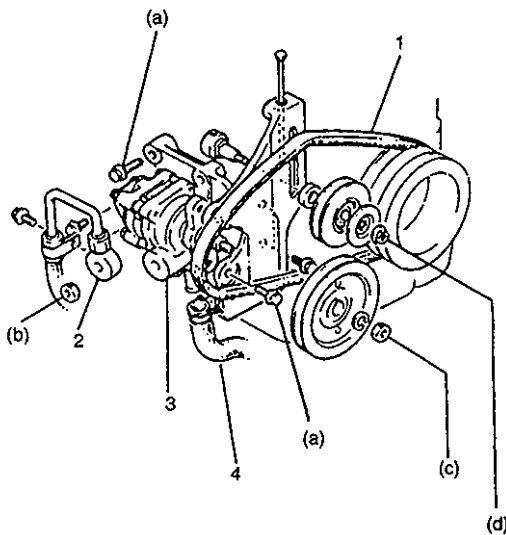

1. Power steering belt
2. High pressure hose
3. Power steering pump
4. Low pressure hose

#### Tightening Torque

- (a): 43 N·m (4.3 kg·m, 31.5 lb-ft)  
 (b): 20 N·m (2.0 kg·m, 14.5 lb-ft)  
 (c): 50 N·m (5.0 kg·m, 36.5 lb-ft)  
 (d): 34 N·m (3.4 kg·m, 24.5 lb-ft)

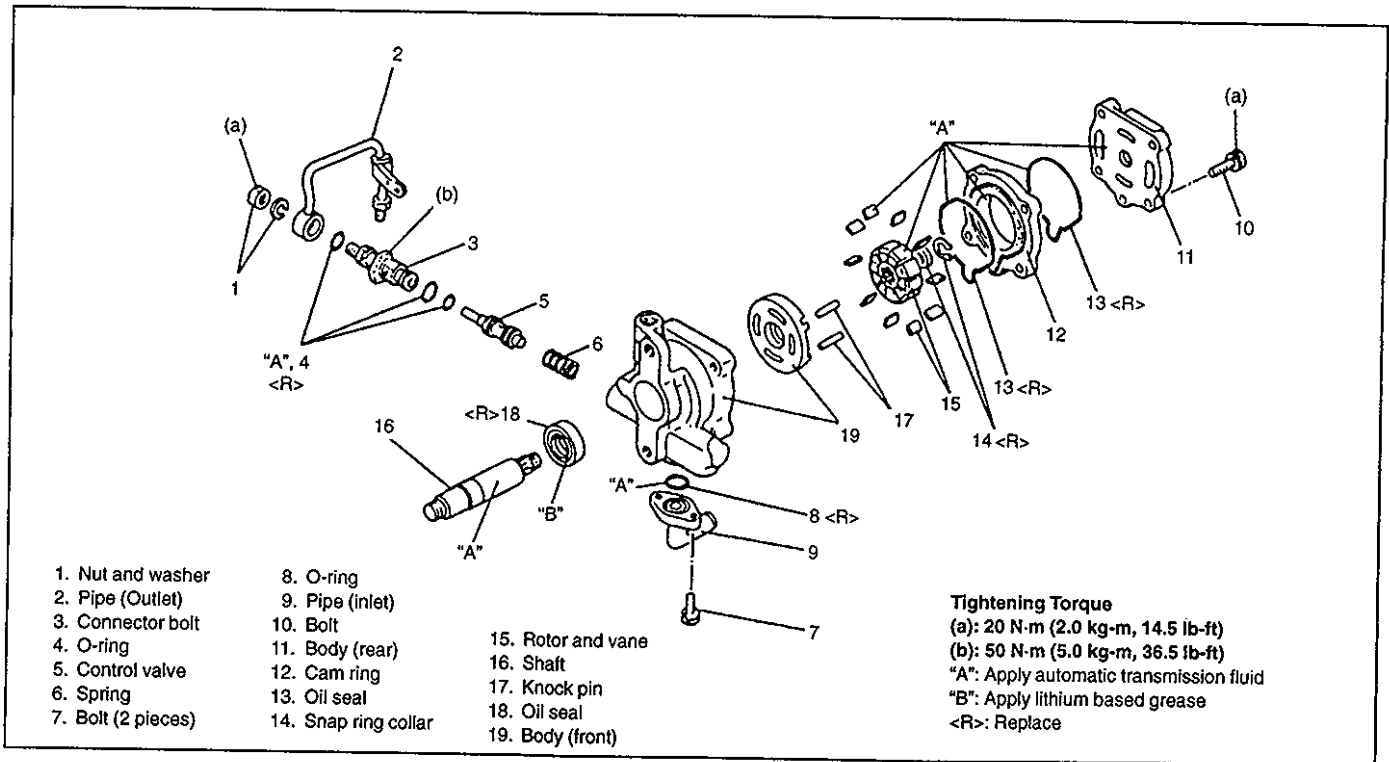

### DISASSEMBLY

Disassemble in order shown in figure.

### ASSEMBLY

Assemble in reverse order of disassembly, using caution as follows.

#### Oil seal

**CAUTION:**

Place body on top of a soft cloth as shown.

Apply ATF to new oil seal, and press in oil seal to body by using a suitable pipe.

#### Rotor and vane

**CAUTION:**

- Verify vane direction (rounded side faces cam ring).
- Verify that vane spins smoothly.
- Apply ATF onto vane.

#### Cam ring and knock pin

**CAUTION:**

- Verify direction of cam ring, align ports, and install onto knock pins.
- Apply ATF onto new O-ring, then install.

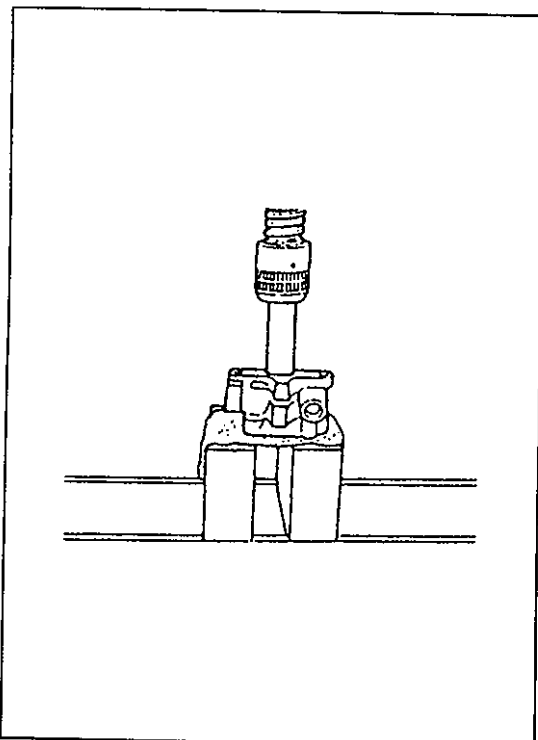

## TIGHTENING TORQUE SPECIFICATIONS

Fastening parts	Tightening torque		
	N·m	kg·m	lb·ft
Pump bracket bolt	43	4.3	31.0
Pump pulley nut	50	5.0	36.5
Tensioner pulley nut	34	3.4	25.0
Outlet pipe nut	20	2.0	14.5
Outlet pipe connector bolt	50	5.0	36.5
Pump body bolts	20	2.0	14.5

## REQUIRED SERVICE MATERIALS

MATERIALS	RECOMMENDED SUZUKI PRODUCT	USE
Power steering fluid	An equivalent of DEXRON®-II, DEXRON®-IIE or DEXRON®-III,	<ul style="list-style-type: none"> <li>● To fill oil tank</li> <li>● Parts lubrication when installing</li> </ul>

## SPECIAL TOOLS

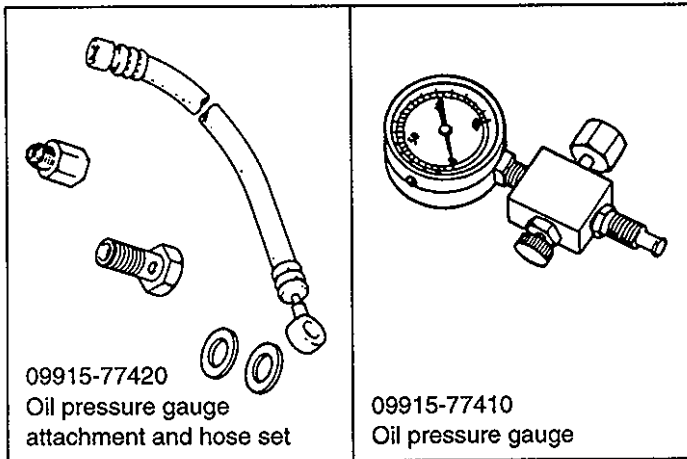

## SECTION 4A2

FRONT DRIVE SHAFT/SHAFT BEARING,  
OIL SEAL

4A2

**NOTE:**

For the descriptions (items) not found in this section, refer to the same section of the Service Manual mentioned in FOREWORD of this manual.

## CONTENTS

ON-VEHICLE SERVICE .....	4A2- 1
Drive Shaft .....	4A2- 1

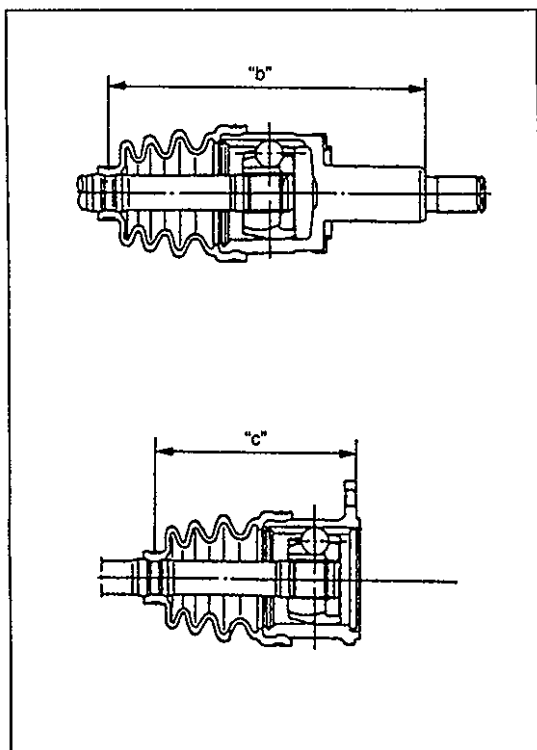

## ON-VEHICLE SERVICE

## DRIVE SHAFT

## ASSEMBLY

Use the procedure described in the same section of Service Manual mentioned in FOREWORD of this manual but note the following point.

- Fitting boot to outer race, adjust so that measurements "b" and "c" become as indicated in figure.

Length "b": 196.8 – 206.8 mm (7.75 – 8.14 in.) (For M/T)

: 203.2 – 213.2 mm (8.00 – 8.40 in.) (For A/T)

"c": 127.5 – 137.5 mm (5.02 – 5.41 in.) (For M/T)

: 125.5 – 135.5 mm (4.94 – 5.33 in.) (For A/T)

Before fixing boot band, insert screwdriver into boot on joint side and allow air to enter boot so that air pressure in boot becomes the same as atmospheric pressure.

## SECTION 6

# ENGINE (RF ENGINE)

**WARNING:**

For vehicles equipped with Supplemental Restraint (Air Bag) System:

- Service on and around the air bag system components or wiring must be performed only by an authorized SUZUKI dealer. Refer to “Air Bag System Components and Wiring Location View” under “General Description” in air bag system section in order to confirm whether you are performing service on or near the air bag system components or wiring. Please observe all WARNINGS and “Service Precautions” under “On-Vehicle Service” in air bag system section before performing service on or around the air bag system components or wiring. Failure to follow WARNINGS could result in unintentional activation of the system or could render the system inoperative. Either of these two conditions may result in severe injury.
- Technical service work must be started at least 90 seconds after the ignition switch is turned to the “LOCK” position and the negative cable is disconnected from the battery. Otherwise, the system may be activated by reserve energy in the Sensing and Diagnostic Module (SDM).

## CONTENTS

<b>GENERAL INFORMATION</b> .....	6- 2
Statement on Cleanliness and Care .....	6- 2
General Information on Engine Service .....	6- 2
<b>ENGINE DIAGNOSIS</b> .....	6- 4
On-Board Diagnostic System .....	6- 4
Precaution in Diagnosing Troubles .....	6- 4
Engine Diagnostic Flow Table .....	6- 5
Engine Diagnosis Table .....	6-10
<b>ENGINE MECHANICAL</b> .....	6A3- 1
<b>ENGINE COOLING</b> .....	6B- 1
<b>ENGINE FUEL</b> .....	6C- 1
<b>ENGINE AND EMISSION CONTROL SYSTEM</b> .....	6E3- 1
<b>CRANKING SYSTEM</b> .....	6G- 1
<b>CHARGING SYSTEM</b> .....	6H- 1
<b>EXHAUST SYSTEM</b> .....	6K- 1

## GENERAL INFORMATION

### STATEMENT ON CLEANLINESS AND CARE

An automobile engine is a combination of many machined, honed, polished and lapped surfaces with tolerances that are measured in the thousands of a millimeter (ten thousands of an inch). Accordingly, when any internal engine parts are serviced, care and cleanliness are important. Throughout this section, it should be understood that proper cleaning and protection of machined surfaces and friction areas is part of the repair procedure. This is considered standard shop practice even if not specifically stated.

- A liberal coating of engine oil should be applied to friction areas during assembly to protect and lubricate the surfaces on initial operation.
- Whenever valve train components, pistons, piston rings, connecting rods, rod bearings, and crankshaft journal bearings are removed for service, they should be retained in order. At the time of installation, they should be installed in the same locations and with the same mating surfaces as when removed.
- Battery cables should be disconnected before any major work is performed on the engine. Failure to disconnect cables may result in damage to wire harness or other electrical parts.

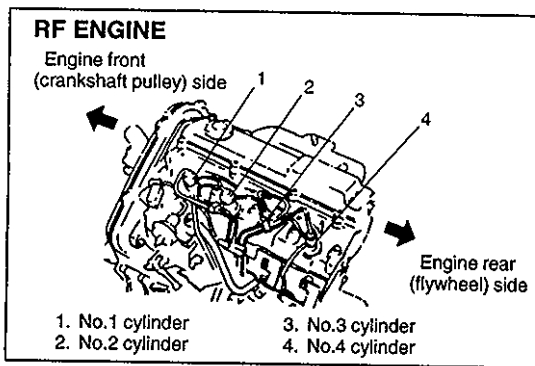

- Throughout this manual, the four cylinders of the engine are identified by numbers: No.1, No.2, No.3 and No.4 as counted from crankshaft pulley side to flywheel side.

### GENERAL INFORMATION ON ENGINE SERVICE

THE FOLLOWING INFORMATION ON ENGINE SERVICE SHOULD BE NOTED CAREFULLY, AS IT IS IMPORTANT IN PREVENTING DAMAGE, AND IN CONTRIBUTING TO RELIABLE ENGINE PERFORMANCE.

- When raising or supporting engine for any reason, do not use a jack under oil pan. Due to small clearance between oil pan and oil pump strainer, jacking against oil pan may cause it to be bent against strainer resulting in damaged oil pick-up unit.
- It should be kept in mind, while working on engine, that 12-volt electrical system is capable of violent and damaging short circuits.  
When performing any work where electrical terminals could possibly be grounded, ground cable of the battery should be disconnected at battery.
- Any time the air cleaner, air intake hose, throttle body or intake manifold is removed, the intake opening should be covered. This will protect against accidental entrance of foreign material which could follow intake passage into cylinder and cause extensive damage when engine is started.

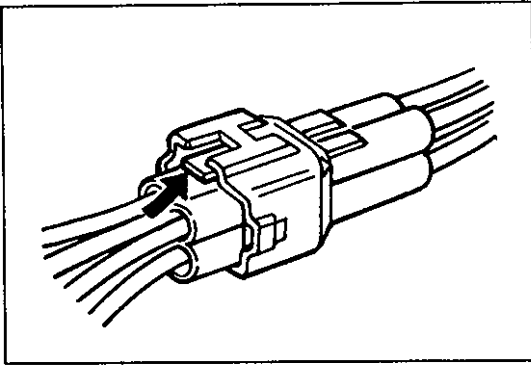

- When disconnecting couplers, don't pull wire harness but make sure to hold coupler itself. With lock type coupler, be sure to unlock before disconnection. Attempt to disconnect coupler without unlocking may result in damage to coupler. When connecting lock type coupler, insert it till clicking sound is heard and connect it securely.

## PRECAUTION ON FUEL SYSTEM SERVICE

- Work must be done with no smoking, in a well-ventilated area and away from any open flames.
- As fuel feed line (between fuel pump and fuel pressure regulator) is still under high fuel pressure even after engine was stopped, loosening or disconnecting fuel feed line directly may cause dangerous spout of fuel to occur where loosened or disconnected. A small amount of fuel may be released after the fuel line is disconnected.

In order to reduce the chance of personal injury, cover the fitting to be disconnected with a shop cloth. Put that cloth in an approved container when disconnection is completed.

- Never run engine with fuel pump relay disconnected when engine and exhaust system are hot.
- Fuel or fuel vapor hose connection varies with each type of pipe. When reconnecting fuel or fuel vapor hose, be sure to connect and clamp each hose correctly referring to left figure. After connecting, make sure that the hose has no twist or kink.
- When installing fuel union bolt gasket, always use new gasket and tighten union bolt to specified torque. See Section 6C for specified torque.
- When installing fuel filter cartridge or sediment level sensor, lubricate its O-ring with spindle oil or fuel.
- When connecting fuel injection pipe flare nut, first tighten flare nut by hand and then tighten it to specified torque.

With short pipe, fit hose as far as it reaches pipe joint as shown.

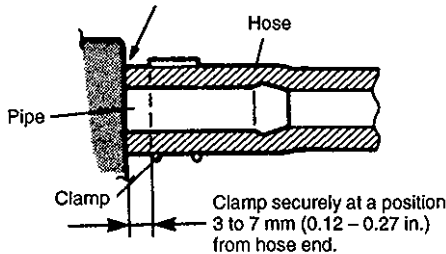

With following type pipe, fit hose as far as its peripheral projection as shown.

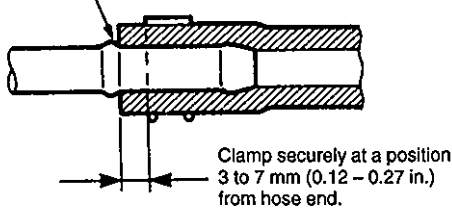

With bent pipe, fit hose as far as its bent part as shown or till pipe is about 20 to 30 mm (0.79 - 1.18 in.) into the hose.

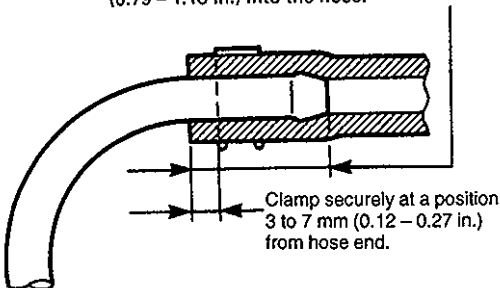

With straight pipe, fit hose till pipe is about 20 to 30 mm (0.79 - 1.18 in.) into the hose.

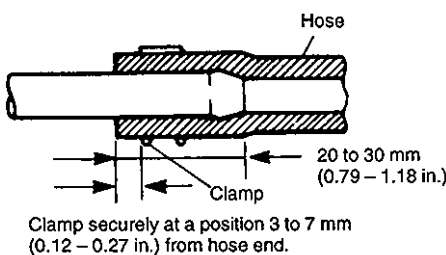

## **ENGINE DIAGNOSIS**

This vehicle is equipped with an engine and emission control system, which controls the A/F mixture, ignition timing, emission, etc. suitably to engine conditions by ECM. ECM has an On-Board Diagnostic system which detects a malfunction in this system.

When diagnosing a trouble in the engine including this system, be sure to have understanding of the outline of "On-Board Diagnostic system" and each item in "Precaution in Diagnosing Trouble" and follow "ENGINE DIAGNOSTIC FLOW TABLE" given below to obtain correct result smoothly.

### **ON-BOARD DIAGNOSTIC SYSTEM**

Refer to "On-Board Diagnostic System" in Section 6E3.

### **PRECAUTION IN DIAGNOSING TROUBLES**

Be sure to read "Precaution in Diagnosing Troubles" in Section 6E3.

## ENGINE DIAGNOSTIC FLOW TABLE

Refer to the following pages for the details of each step.

STEP	ACTION	YES	NO
1	Customer Complaint Analysis 1) Perform customer complaint analysis. Was customer complaint analysis performed?	Go to Step 2.	Perform customer complaint analysis.
2	Diagnostic Trouble Code (DTC) Check, Record and Clearance 1) Check for DTC referring to "DTC Check" in Section 6E3. Is there any malfunction DTC(s)?	1) Print DTC or write it down and clear it by referring to "DTC Clearance" in Section 6E3. 2) Go to Step 3.	Go to Step 4.
3	Visual Inspection 1) Perform Visual inspection referring to the "Visual Inspection" in this section. Is there any faulty condition?	1) Repair or replace malfunction part. 2) Go to Step 11.	Go to Step 5.
4	Visual Inspection 1) Perform visual inspection referring to the "Visual Inspection" in this section. Is there any faulty condition?		Go to Step 8.
5	Trouble Symptom Confirmation 1) Confirm trouble symptom referring to the "Trouble Symptom Confirmation" in this section. Is trouble symptom identified?	Go to Step 6.	Go to Step 7.
6	Rechecking and Record of DTC 1) Recheck for DTC referring to "DTC Check" in Section 6E3. Is there any DTC(s)?	Go to Step 9.	Go to Step 8.
7	Rechecking and Record of DTC 1) Recheck for DTC referring to "DTC Check" in Section 6E3. Is there any malfunction DTC(s)?		Go to Step 10.
8	Engine Basic Inspection and Engine Diagnosis Table 1) Check and repair according to "Engine Basic Check" and "Engine Diagnosis Table" in this section. Are check and repair complete?	Go to Step 11.	1) Check and repair malfunction part(s). 2) Go to Step 11.
9	Trouble shooting for DTC 1) Check and repair according to applicable DTC diag. flow table in Section 6E3. Are check and repair complete?		
10	Check for Intermittent Problems 1) Check for intermittent problems referring to "Check for Intermittent Problem" in this section. Is there any faulty condition?	1) Repair or replace malfunction part(s). 2) Go to Step 11.	Go to Step 11.
11	Final Confirmation Test 1) Clear DTC if any. 2) Perform final confirmation test referring to "Final Confirmation Test" in this section. Is there any problem symptom, malfunction DTC or abnormal condition?	Go to Step 6.	End.

**1. CUSTOMER COMPLAINT ANALYSIS**

Record details of the problem (failure, complaint) and how it occurred as described by the customer. For this purpose, use of such an inspection form will facilitate collecting information to the point required for proper analysis and diagnosis.

**CUSTOMER PROBLEM INSPECTION FORM (EXAMPLE)**

User name:	Model:	VIN:	
Date of issue:	Date of Reg.:	Date of problem:	Mileage:

**PROBLEM SYMPTOMS**

<input type="checkbox"/> <b>Difficult Starting</b> <input type="checkbox"/> No cranking <input type="checkbox"/> No initial combustion <input type="checkbox"/> No combustion <input type="checkbox"/> Poor starting at ( <input type="checkbox"/> cold <input type="checkbox"/> warm <input type="checkbox"/> always) <input type="checkbox"/> Other _____	<input type="checkbox"/> <b>Poor Driveability</b> <input type="checkbox"/> Hesitation on acceleration <input type="checkbox"/> Back fire/ <input type="checkbox"/> After fire <input type="checkbox"/> Lack of power <input type="checkbox"/> Surging <input type="checkbox"/> Abnormal knocking <input type="checkbox"/> Other _____
<input type="checkbox"/> <b>Poor idling</b> <input type="checkbox"/> Poor fast idle <input type="checkbox"/> Abnormal idling speed ( <input type="checkbox"/> High <input type="checkbox"/> Low) (     r/min.) <input type="checkbox"/> Unstable <input type="checkbox"/> Hunting (     r/min. to     r/min.) <input type="checkbox"/> Other _____	<input type="checkbox"/> <b>Engine Stall when</b> <input type="checkbox"/> Immediately after start <input type="checkbox"/> Accelerator pedal is depressed <input type="checkbox"/> Accelerator pedal is released <input type="checkbox"/> Load is applied <input type="checkbox"/> A/C <input type="checkbox"/> Electric load <input type="checkbox"/> P/S <input type="checkbox"/> Other _____ <input type="checkbox"/> Other _____
<input type="checkbox"/> OTHERS:	

**VEHICLE/ENVIRONMENTAL CONDITION WHEN PROBLEM OCCURS****Environmental Condition**

Weather	<input type="checkbox"/> Fair <input type="checkbox"/> Cloudy <input type="checkbox"/> Rain <input type="checkbox"/> Snow <input type="checkbox"/> Always <input type="checkbox"/> Other _____
Temperature	<input type="checkbox"/> Hot <input type="checkbox"/> Warm <input type="checkbox"/> Cool <input type="checkbox"/> Cold (   °F/   °C) <input type="checkbox"/> Always
Frequency	<input type="checkbox"/> Always <input type="checkbox"/> Sometimes (   times/   day, month) <input type="checkbox"/> Only once <input type="checkbox"/> Under certain condition
Road	<input type="checkbox"/> Urban <input type="checkbox"/> Suburb <input type="checkbox"/> Highway <input type="checkbox"/> Mountainous ( <input type="checkbox"/> Uphill <input type="checkbox"/> Downhill) <input type="checkbox"/> Tarmacadam <input type="checkbox"/> Gravel <input type="checkbox"/> Other _____

**Vehicle Condition**

Engine Condition	<input type="checkbox"/> Cold <input type="checkbox"/> Warming up phase <input type="checkbox"/> Warmed up <input type="checkbox"/> Always <input type="checkbox"/> Other at starting <input type="checkbox"/> Immediately after start <input type="checkbox"/> Racing without load <input type="checkbox"/> Engine speed (     r/min)
Vehicle condition	<input type="checkbox"/> During driving: <input type="checkbox"/> Constant speed <input type="checkbox"/> Accelerating <input type="checkbox"/> Decelerating <input type="checkbox"/> Right hand corner <input type="checkbox"/> left hand corner <input type="checkbox"/> When shifting (Lever position   ) <input type="checkbox"/> At stop <input type="checkbox"/> Vehicle speed when problem occurs (   km/h,   Mile/h) <input type="checkbox"/> Other _____

Malfunction indicator lamp condition	<input type="checkbox"/> Always ON <input type="checkbox"/> Sometimes ON <input type="checkbox"/> Always OFF <input type="checkbox"/> Good condition
Diagnostic trouble code	First check: <input type="checkbox"/> No code <input type="checkbox"/> Normal code <input type="checkbox"/> Malfunction code (     )
	Second check: <input type="checkbox"/> No code <input type="checkbox"/> Normal code <input type="checkbox"/> Malfunction code (     )

**NOTE:**

The above form is a standard sample. It should be modified according to conditions characteristic of each market.

**2. DIAGNOSTIC TROUBLE CODE (DTC) CHECK, RECORD AND CLEARANCE**

First, check DTC referring to "DTC Check" in Section 6E3. If DTC is indicated, print it or write it down and then clear it by referring to "DTC Clearance" in Section 6E3. DTC indicates malfunction that occurred in the system but does not indicate whether it exists now or it occurred in the past and the normal condition has been restored now. To check which case applies, check the symptom in question according to Step 5 and recheck DTC according to Step 6 or 7.

Attempt to diagnose a trouble based on DTC in this step only or failure to clear the DTC in this step will lead to incorrect diagnosis, trouble diagnosis of a normal circuit or difficulty in troubleshooting.

**NOTE:**

**If only Automatic transmission related DTC is indicated in this step, perform trouble diagnosis according to "Diagnosis" in Section 7B1.**

**3. and 4. VISUAL INSPECTION**

Be sure to perform visual check of the following items that support proper function of the engine.

INSPECTION ITEM	REFERRING SECTION
● Engine oil --- level, leakage	Section 0B
● Engine coolant --- level, leakage	Section 0B
● Fuel --- level, leakage	Section 0B
● A/T fluid --- level, leakage	Section 0B
● Air cleaner element --- dirt, clogging	Section 0B
● Battery --- fluid level, corrosion of terminal	
● Water pump belt and/or cooling fan belt --- tension, damage	Section 0B
● Throttle cable --- play, installation	Section 6E3
● A/T throttle cable --- play, installation	
● Vacuum hoses of air intake system --- disconnection, looseness, deterioration, bend	
● Connectors of electric wire harness --- disconnection, friction	
● Fuses --- burning	Section 8
● Parts --- installation, bolt --- looseness	
● Parts --- deformation	
● Other parts that can be checked visually	
Also check following items at engine start, if possible	
● Malfunction indicator lamp (glow light)	Section 6E3
● Charge warning lamp	Section 6H
● Engine oil pressure warning lamp	Section 8
● Engine coolant temp. meter	Section 8
● Fuel lever meter	Section 8
● Abnormal air being inhaled from air intake system	} Operation
● Exhaust system --- leakage of exhaust gas, noise	
● Other parts that can be checked visually	

**5. TROUBLE SYMPTOM CONFIRMATION**

Based on information obtained in Step 1 Customer complaint analysis and Step 2 DTC check, confirm trouble symptoms. Also, reconfirm DTC according to "DTC Confirmation Procedure" in Section 6E3.

**6. and 7. RECHECKING AND RECORD OF DTC**

Refer to "DTC Check" in section 6E3 for checking procedure.

**8. ENGINE BASIC INSPECTION AND ENGINE DIAGNOSIS TABLE**

Perform basic engine check according to the "Engine Basic Inspection Flow Table" first. When the end of the flow table has been reached, check the parts of the system suspected as a possible cause referring to "ENGINE DIAGNOSIS TABLE" and based on symptoms appearing on the vehicle (symptoms obtained through steps of customer complaint analysis, trouble symptom confirmation and/or basic engine check) and repair or replace faulty parts, if any.

**ENGINE BASIC INSPECTION FLOW TABLE**

STEP	ACTION	YES	NO
1	Was "ENGINE DIAG. FLOW TABLE" performed?	Go to Step 2.	Go to "ENGINE DIAG. FLOW TABLE".
2	Check battery voltage. Is it 11 V or more?	Go to Step 3.	Charge or replace battery.
3	Is engine cranked?	Go to Step 4.	Go to "DIAGNOSIS" in Section 6G.
4	Does engine start?	Go to Step 5.	Go to Step 7.
5	Check engine idle speed referring to "Idle Speed Adjustment" in Section 6E3. Is check result as specified?	Go to Step 6.	Go to "ENGINE DIAGNOSIS TABLE" in this section.
6	Check injection timing referring to "Injection Timing Adjustment" in Section 6E3. Is check result as specified?	Go to "ENGINE DIAGNOSIS TABLE" in this section.	Adjust injection timing.
7	<b>Fuel injection condition inspection</b> Loosen fuel injection nozzle side flare nut at each cylinder one by one in order and crank the engine. Is fuel injected intermittently at each cylinder?	Go to Step 8.	Check fuel injection pipe for clogs. If fuel injection pipe is OK, replace fuel injection pump.
8	<b>Cylinder Balance Test</b> While idling engine, slowly loosen/tighten fuel injection nozzle side flare nut at each cylinder one by one in order, and check for change in engine speed and vibration. Does Idle speed drop and engine vibration change equally at all cylinders?  <b>NOTE:</b> • If idle speed will not drop or drops less at one cylinder, distribution at cylinder is weak. • If idle speed stabilizes when a small amount of fuel is released through flare nut, distribution at cylinder is strong.	Go to Step 9.	Perform Compression Inspection. (Refer to Section 6A3.)
9	Check fuel injection nozzle referring to "Fuel Injection Nozzle" in Section 6E3. Is it in good condition?	Go to "ENGINE DIAGNOSIS TABLE" in this section.	Repair or replace.

**9. TROUBLESHOOTING FOR DTC**

Based on the DTC indicated in Step 6 or 7 and referring to the applicable DTC diag. flow table in Section 6E1 or 6E2, locate the cause of the trouble, namely in a sensor, switch, wire harness, connector, actuator, ECM (PCM) or other part and repair or replace faulty parts.

**10. CHECK FOR INTERMITTENT PROBLEM**

Check parts where an intermittent trouble is easy to occur (e.g., wire harness, connector, etc.), referring to "INTERMITTENT AND POOR CONNECTION" in Section 0A and related circuit of DTC recorded in step 2.

**11. FINAL CONFIRMATION TEST**

Confirm that the problem symptom has gone and the engine is free from any abnormal conditions. If what has been repaired is related to the DTC, clear the DTC once, perform DTC confirmation procedure and confirm that no malfunction DTC (a normal code) is indicated.

## ENGINE DIAGNOSIS TABLE

Condition	Possible Cause	Reference Item
<p>Hard starting (Engine cranks OK)</p>	<p><b>Fuel system out of order.</b></p> <ul style="list-style-type: none"> <li>● Lack of fuel in fuel tank</li> <li>● Fuel filter <ul style="list-style-type: none"> <li>– Dirty or clogged</li> <li>– Water or sir mixed in</li> </ul> </li> <li>● Dirty or clogged fuel hose or pipe</li> <li>● Fuel injection pipe <ul style="list-style-type: none"> <li>– Cracks</li> <li>– Fuel leakage from joints</li> </ul> </li> <li>● Fuel injection nozzle <ul style="list-style-type: none"> <li>– Incorrect valve opening pressure</li> <li>– Seized needle valve</li> <li>– Improperly installed nozzle holder</li> <li>– Faulty nozzle gasket</li> </ul> </li> </ul> <p><b>Engine and emission control system out of order.</b></p> <ul style="list-style-type: none"> <li>● Faulty ECM</li> <li>● Faulty ECM 15A fuse</li> <li>● Faulty main relay</li> <li>● Faulty spill valve relay</li> <li>● Faulty fuel injection pump <ul style="list-style-type: none"> <li>– Incorrect injection timing</li> <li>– Air mixed in</li> <li>– Pump internal damage</li> <li>– Faulty NE sensor</li> <li>– Faulty spill valve</li> <li>– Faulty <math>\theta</math> compensation resistance</li> <li>– Faulty <math>\gamma</math> compensation resistance</li> <li>– Faulty timer control valve</li> </ul> </li> </ul> <p><b>Glow system out of order.</b></p> <ul style="list-style-type: none"> <li>● Faulty glow plug</li> <li>● Faulty glow relay</li> <li>● Faulty glow fusible link</li> </ul> <p><b>Low compression.</b></p> <ul style="list-style-type: none"> <li>● Incorrect valve lash</li> <li>● Compression leak from valve seat</li> </ul> <ul style="list-style-type: none"> <li>● Sticky valve stem</li> </ul> <ul style="list-style-type: none"> <li>● Weak or damaged valve springs</li> <li>● Compression leak at cylinder head gasket</li> <li>● Sticking or damaged piston ring</li> <li>● Worn piston, ring or cylinder</li> </ul> <p><b>Immobilizer control system out of order.</b></p> <p><b>Others</b></p> <ul style="list-style-type: none"> <li>● Broken valve timing belt</li> </ul>	<p>Refill.</p> <p>Replace. Repair. Clean.</p> <p>Replace. Correct.</p> <p>Adjust. Replace. Repair. Replace.</p> <p>Inspect and replace. Replace. Inspect and replace. Inspect and replace.</p> <p>Adjust. Air bleeding of fuel system. Replace. Inspect and replace. Inspect and replace. Inspect and replace. Inspect and replace. Inspect and replace.</p> <p>Inspect and replace. Inspect and replace. Inspect and replace.</p> <p>Adjust. Remove cylinder head and lap valves. Correct or replace valve and valve guide. Replace valve springs. Repair or replace.</p> <p>Replace piston rings. Replace ring and piston. Rebore or replace cylinder. Refer to Section 8G.</p> <p>Replace timing belt and repair valve train.</p>

Condition	Possible Cause	Reference Item
Improper engine idling or engine fails to idle	<p><b>Intake system out of order.</b></p> <ul style="list-style-type: none"> <li>● Clogged air cleaner element</li> <li>● Intake shutter solenoid valve</li> </ul> <p><b>Fuel system out of order.</b></p> <ul style="list-style-type: none"> <li>● Shortage of fuel in fuel tank</li> <li>● Fuel filter <ul style="list-style-type: none"> <li>– Dirty or clogged</li> <li>– Water or sir mixed in</li> </ul> </li> <li>● Dirty or clogged fuel hose or pipe</li> <li>● Fuel injection pipe <ul style="list-style-type: none"> <li>– Cracks</li> <li>– Fuel leakage from joints</li> </ul> </li> <li>● Fuel injection nozzle <ul style="list-style-type: none"> <li>– Incorrect valve opening pressure</li> <li>– Seized needle valve</li> <li>– Improperly installed nozzle holder</li> <li>– Faulty nozzle gasket</li> </ul> </li> </ul> <p><b>Engine overheating.</b></p> <p><b>Engine and emission control system out of order.</b></p> <ul style="list-style-type: none"> <li>● Faulty ECM</li> <li>● Faulty ECM 15A fuse</li> <li>● Faulty main relay</li> <li>● Faulty spill valve relay</li> <li>● Faulty fuel injection pump <ul style="list-style-type: none"> <li>– Incorrect injection timing</li> <li>– Air mixed in</li> <li>– Pump internal damage</li> <li>– Faulty NE sensor</li> <li>– Faulty spill valve</li> <li>– Faulty <math>\theta</math> compensation resistance</li> <li>– Faulty <math>\gamma</math> compensation resistance</li> <li>– Faulty timer control valve</li> </ul> </li> <li>● Faulty VSS</li> <li>● Faulty CKP sensor</li> <li>● Faulty ECT sensor</li> </ul> <p><b>Glow system out of order.</b></p> <ul style="list-style-type: none"> <li>● Faulty glow plug</li> <li>● Faulty glow relay</li> </ul> <p><b>EGR system out of order.</b></p> <ul style="list-style-type: none"> <li>● Faulty EGR solenoid valve</li> <li>● Faulty EGR valve</li> </ul> <p><b>Low compression.</b></p> <p><b>Others</b></p> <ul style="list-style-type: none"> <li>● Faulty A/T shift switch</li> <li>● Faulty A/C signal</li> </ul>	<p>Clean or replace. Inspect and replace.</p> <p>Refill.</p> <p>Replace. Repair. Clean.</p> <p>Replace. Repair.</p> <p>Adjust. Replace. Repair. Replace. Refer to "Overheating" section.</p> <p>Inspect and replace. Replace. Inspect and replace. Inspect and replace.</p> <p>Adjust. Repair. Inspect and replace. Inspect and replace. Inspect and replace. Inspect and replace. Inspect and replace. Inspect and replace. Inspect and replace. Inspect and replace. Inspect and replace.</p> <p>Inspect and replace. Inspect and replace.</p> <p>Inspect and repair or replace EGR system. Inspect and repair or replace EGR system.</p> <p>Previously outlined.</p> <p>Inspect and replace. Inspect and replace.</p>

Condition	Possible Cause	Reference Item
<b>Abnormal knocking</b>	<p><b>Fuel system out of order.</b></p> <ul style="list-style-type: none"> <li>● Fuel injection pipe <ul style="list-style-type: none"> <li>– Cracks</li> <li>– Fuel leakage from joints</li> </ul> </li> <li>● Fuel injection nozzle <ul style="list-style-type: none"> <li>– Incorrect valve opening pressure</li> <li>– Seized needle valve</li> <li>– Improperly installed nozzle holder</li> <li>– Faulty nozzle gasket</li> </ul> </li> </ul> <p><b>Engine and emission control system out of order.</b></p> <ul style="list-style-type: none"> <li>● Faulty ECM</li> <li>● Faulty fuel injection pump <ul style="list-style-type: none"> <li>– Faulty <math>\gamma</math> compensation resistance</li> <li>– Faulty timer control valve</li> </ul> </li> <li>● Faulty boost sensor</li> <li>● Faulty CKP sensor</li> <li>● Faulty ECT sensor</li> </ul>	<p>Replace. Repair.</p> <p>Adjust. Replace. Repair. Replace.</p> <p>Inspect and replace. Inspect and replace. Inspect and replace. Inspect and replace. Inspect and replace. Inspect and replace.</p>
<b>Engine hesitates when accelerating</b>	<p><b>Intake system out of order.</b></p> <ul style="list-style-type: none"> <li>● Clogged air cleaner element</li> <li>● Faulty turbocharger.</li> </ul> <p><b>Fuel system out of order.</b></p> <ul style="list-style-type: none"> <li>● Fuel filter <ul style="list-style-type: none"> <li>– Dirty or clogged</li> <li>– Water or air mixed in</li> </ul> </li> <li>● Dirty or clogged fuel hose or pipe</li> <li>● Fuel injection pipe <ul style="list-style-type: none"> <li>– Cracks</li> <li>– Fuel leakage from joints</li> </ul> </li> <li>● Fuel injection nozzle <ul style="list-style-type: none"> <li>– Incorrect valve opening pressure</li> <li>– Seized needle valve</li> <li>– Improperly installed nozzle holder</li> <li>– Faulty nozzle gasket</li> </ul> </li> </ul> <p><b>Engine overheating.</b></p> <p><b>Engine and emission control system out of order.</b></p> <ul style="list-style-type: none"> <li>● Faulty ECM</li> <li>● Faulty fuel injection pump <ul style="list-style-type: none"> <li>– Incorrect injection timing</li> <li>– Air mixed in</li> <li>– Pump internal damage</li> <li>– Faulty <math>\theta</math> compensation resistance</li> <li>– Faulty <math>\gamma</math> compensation resistance</li> <li>– Faulty timer control valve</li> </ul> </li> <li>● Faulty TP sensor</li> <li>● Faulty boost sensor</li> <li>● Faulty CKP sensor</li> <li>● Faulty ECT sensor</li> <li>● Faulty IAT sensor</li> </ul> <p><b>EGR system out of order.</b></p> <ul style="list-style-type: none"> <li>● Faulty EGR solenoid valve</li> </ul> <p>● Faulty EGR valve</p> <p><b>Low compression.</b></p>	<p>Clean or replace. Replace.</p> <p>Replace. Repair. Clean or replace.</p> <p>Replace. Repair.</p> <p>Adjust. Replace. Repair. Replace. Refer to "Overheating" section.</p> <p>Inspect and replace.</p> <p>Adjust. Repair. Inspect and replace. Inspect and replace. Inspect and replace. Inspect and replace. Inspect and replace. Inspect and replace. Inspect and replace. Inspect and replace.</p> <p>Inspect and repair or replace EGR system. Inspect and repair or replace EGR system. Previously outlined.</p>

Condition	Possible Cause	Reference Item
<b>Hunts while driving</b>	<p><b>Fuel system out of order.</b></p> <ul style="list-style-type: none"> <li>● Fuel filter <ul style="list-style-type: none"> <li>– Dirty or clogged</li> <li>– Water or air mixed in</li> </ul> </li> <li>● Fuel injection nozzle <ul style="list-style-type: none"> <li>– Incorrect valve opening pressure</li> <li>– Seized needle valve</li> <li>– Improperly installed nozzle holder</li> <li>– Faulty nozzle gasket</li> </ul> </li> </ul> <p><b>Engine and emission control system out of order.</b></p> <ul style="list-style-type: none"> <li>● Faulty ECM</li> <li>● Faulty fuel injection pump <ul style="list-style-type: none"> <li>– Pump internal damage</li> <li>– Faulty timer control valve</li> </ul> </li> <li>● Faulty TP sensor</li> </ul> <p><b>EGR system out of order.</b></p> <ul style="list-style-type: none"> <li>● Faulty EGR solenoid valve</li> <li>● Faulty EGR valve</li> </ul>	<p>Replace. Repair.</p> <p>Adjust. Replace. Repair. Replace.</p> <p>Inspect and replace.</p> <p>Replace. Inspect and replace. Inspect and replace.</p> <p>Inspect and repair or replace EGR system. Inspect and repair or replace EGR system.</p>
<b>Overheating</b>	<ul style="list-style-type: none"> <li>● Insufficient coolant</li> <li>● Loose water pump belt</li> <li>● Inoperative thermostat</li> <li>● Poor water pump performance</li> <li>● Clogged or leaky radiator</li> <li>● Improper engine oil grade</li> <li>● Clogged oil filter or oil strainer</li> <li>● Not enough oil</li> <li>● Poor oil pump performance</li> <li>● Oil leakage</li> <li>● Dragging brakes</li> <li>● Slipping clutch</li> <li>● Blown cylinder head gasket</li> </ul>	<p>Replenish. Adjust. Replace. Replace. Flush, repair or replace. Replace with proper grade oil. Replace or clean (oil strainer). Replenish. Repair or replace. Repair. Repair or replace. Repair or replace. Replace.</p>

Condition	Possible Cause	Reference Item
<b>Excessive engine oil consumption</b>	<b>Oil leakage</b> <ul style="list-style-type: none"> <li>● Loose oil drain plug</li> <li>● Loose oil pan bolts</li> <li>● Deteriorated or broken oil pan sealant</li> <li>● Leaky crankshaft oil seal</li> <li>● Leaky cylinder head cover gasket</li> <li>● Improper tightening of oil filter</li> <li>● Loose oil pressure switch</li> <li>● Blown cylinder head gasket</li> <li>● Leaky crankshaft pulley oil seal</li> </ul> <b>Oil entering combustion chamber</b> <ul style="list-style-type: none"> <li>● Sticky piston ring</li> <li>● Worn piston and cylinder</li>   <li>● Worn piston ring groove and ring</li> <li>● Improper location of piston ring gap</li> <li>● Worn or damaged valve stem seal</li> <li>● Worn valve stem</li> </ul>	Tighten. Tighten. Replace sealant. Replace. Replace. Tighten. Tighten. Replace. Replace.  Remove carbon and replace rings. Replace or rebore cylinder, and replace piston. Replace piston and ring. Reposition ring gap. Replace. Replace.
<b>Low oil pressure</b>	<ul style="list-style-type: none"> <li>● Improper oil viscosity</li> <li>● Malfunctioning oil pressure switch</li> <li>● Not enough oil</li> <li>● Clogged oil strainer</li> <li>● Functional deterioration of oil pump</li> <li>● Worn oil pump relief valve</li> <li>● Excessive clearance in various sliding parts</li> </ul>	Use oil of proper viscosity. Replace. Replenish. Clean. Replace. Replace. Replace worn parts.
<b>Engine noise</b> Note: Before checking the mechanical noise, make sure that: <ul style="list-style-type: none"> <li>● Injection timing is properly adjusted.</li> <li>● Specified fuel is used.</li> </ul>	<b>Valve noise.</b> <ul style="list-style-type: none"> <li>● Improper valve lash</li> <li>● Worn valve stem and guide</li> <li>● Weak or broken valve spring</li> <li>● Warped or bent valve</li> </ul> <b>Piston, ring and cylinder noise.</b> <ul style="list-style-type: none"> <li>● Worn piston, ring and cylinder bore</li> </ul> <b>Connecting rod noise.</b> <ul style="list-style-type: none"> <li>● Worn crankpin bearing</li> <li>● Worn crankpin</li>   <li>● Loose connecting rod nuts</li> </ul> <b>Low oil pressure.</b> <b>Crankshaft noise.</b> <ul style="list-style-type: none"> <li>● Worn crankshaft journal bearing</li> <li>● Worn crankshaft journal</li>   <li>● Loose lower crankcase (bearing cap) bolts</li> <li>● Excessive crankshaft thrust play</li> </ul> <b>Engine and emission control system out of order.</b>	Adjust. Replace. Replace. Replace.  Rebore or replace cylinder. Replace piston and ring.  Replace. Repair by grinding or replace crankshaft. Tighten nuts to specification. Previously outlined.  Replace. Repair by grinding or replace crankshaft. Tighten bolts to specification.  Replace thrust bearing. Refer to Section 6E3.

Condition	Possible Cause	Reference Item
<b>White smoke</b>	<p><b>Intake system out of order.</b></p> <ul style="list-style-type: none"> <li>● Clogged air cleaner element</li> <li>● Intake shutter solenoid valve</li> </ul> <p><b>Fuel system out of order.</b></p> <ul style="list-style-type: none"> <li>● Fuel injection nozzle <ul style="list-style-type: none"> <li>– Incorrect valve opening pressure</li> <li>– Seized needle valve</li> <li>– Improperly installed nozzle holder</li> <li>– Faulty nozzle gasket</li> </ul> </li> </ul> <p><b>Engine and emission control system out of order.</b></p> <ul style="list-style-type: none"> <li>● Faulty ECM</li> <li>● Faulty fuel injection pump <ul style="list-style-type: none"> <li>– Pump internal damage</li> <li>– Faulty spill valve</li> <li>– Faulty <math>\gamma</math> compensation resistance</li> <li>– Faulty timer control valve</li> </ul> </li> <li>● Faulty boost sensor</li> <li>● Faulty TP sensor</li> <li>● Faulty CKP sensor</li> </ul> <p><b>Glow system out of order.</b></p> <ul style="list-style-type: none"> <li>● Faulty glow plug</li> <li>● Faulty glow relay</li> <li>● Faulty glow fusible link</li> </ul>	<p>Clean or replace. Inspect and replace.</p> <p>Adjust. Replace. Repair. Replace.</p> <p>Inspect and replace.</p> <p>Replace. Inspect and replace. Inspect and replace. Inspect and replace. Inspect and replace. Inspect and replace.</p> <p>Inspect and replace. Inspect and replace. Inspect and replace.</p>
<b>Black smoke</b>	<p><b>Intake system out of order.</b></p> <ul style="list-style-type: none"> <li>● Faulty turbocharger</li> </ul> <p><b>Fuel system out of order.</b></p> <ul style="list-style-type: none"> <li>● Fuel injection nozzle <ul style="list-style-type: none"> <li>– Incorrect valve opening pressure</li> <li>– Seized needle valve</li> <li>– Improperly installed nozzle holder</li> <li>– Faulty nozzle gasket</li> </ul> </li> </ul> <p><b>Engine and emission control system out of order.</b></p> <ul style="list-style-type: none"> <li>● Faulty ECM</li> <li>● Faulty fuel injection pump <ul style="list-style-type: none"> <li>– Incorrect injection timing.</li> <li>– Pump internal damage</li> <li>– Faulty spill valve</li> </ul> </li> <li>● Faulty TP sensor</li> </ul> <p><b>EGR system out of order.</b></p> <ul style="list-style-type: none"> <li>● Faulty EGR solenoid valve</li> </ul> <ul style="list-style-type: none"> <li>● Faulty EGR valve</li> </ul>	<p>Inspect and replace.</p> <p>Adjust. Replace. Repair. Replace.</p> <p>Inspect and replace.</p> <p>Adjust. Replace. Inspect and replace. Inspect and replace.</p> <p>Inspect and repair or replace EGR system. Inspect and repair or replace EGR system.</p>

## SECTION 6A3

# ENGINE MECHANICAL (RF ENGINE)

**WARNING:**

For vehicles equipped with Supplemental Restraint (Air Bag) System:

- Service on and around the air bag system components or wiring must be performed only by an authorized SUZUKI dealer. Refer to “Air Bag System Components and Wiring Location View” under “General Description” in air bag system section in order to confirm whether you are performing service on or near the air bag system components or wiring. Please observe all WARNINGS and “Service Precautions” under “On-Vehicle Service” in air bag system section before performing service on or around the air bag system components or wiring. Failure to follow WARNINGS could result in unintentional activation of the system or could render the system inoperative. Either of these two conditions may result in severe injury.
- Technical service work must be started at least 90 seconds after the ignition switch is turned to the “LOCK” position and the negative cable is disconnected from the battery. Otherwise, the system may be activated by reserve energy in the Sensing and Diagnostic Module (SDM).

6A3

## CONTENTS

<b>MAINTENANCE</b> .....	6A3- 2
Oil Level Check, Oil Change and Oil Filter Change .....	6A3- 2
Compression Check .....	6A3- 2
Oil Pressure Check .....	6A3- 3
Valve Lash (Clearance) .....	6A3- 4
<b>REPAIR</b> .....	6A3- 5
Air Cleaner Element .....	6A3- 5
Intake and Exhaust System .....	6A3- 6
Timing Belt, Pulley and Belt Tensioner .....	6A3- 8
Valve, Cylinder Head and Camshaft .....	6A3-16
Oil Filter, Oil Pressure Switch, Oil Cooler and Engine Hanger .....	6A3-31
Oil Pan, Oil Pump and Drive Plate .....	6A3-33
Engine Assembly .....	6A3-41
Cylinder Block, Piston, Connecting Rod and Crankshaft .....	6A3-46
<b>SPECIAL TOOLS</b> .....	6A3-58
<b>REQUIRED SERVICE MATERIALS</b> .....	6A3-59

## MAINTENANCE

### OIL LEVEL CHECK, OIL CHANGE AND OIL FILTER CHANGE

Refer to SECTION 0B in this manual.

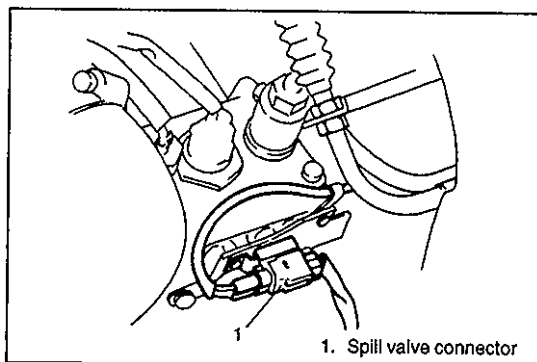

### COMPRESSION CHECK

- 1) Warm up engine.
- 2) Stop engine after warming up.
- 3) Disconnect spill valve connector.
- 4) Remove intercooler.
- 5) Remove all fuel injection pipes, nozzles, washers and corrugate washers.
- 6) Install special tool to injection nozzle hole.

#### Special Tool

(A): 09912-57820

(B): 09912-57830

- 7) Crank engine and inspect compression pressure.

#### Compression pressure specification

(at cranking engine (engine speed is about 200 rpm)):

Standard: 3.0 MPa (30 kg/cm<sup>2</sup>, 427 psi)

Minimum: 2.7 MPa (27 kg/cm<sup>2</sup>, 348 psi)

Maximum difference between cylinders:

0.3 MPa (3 kg/cm<sup>2</sup>, 43 psi)

- 8) Check each cylinder as above.

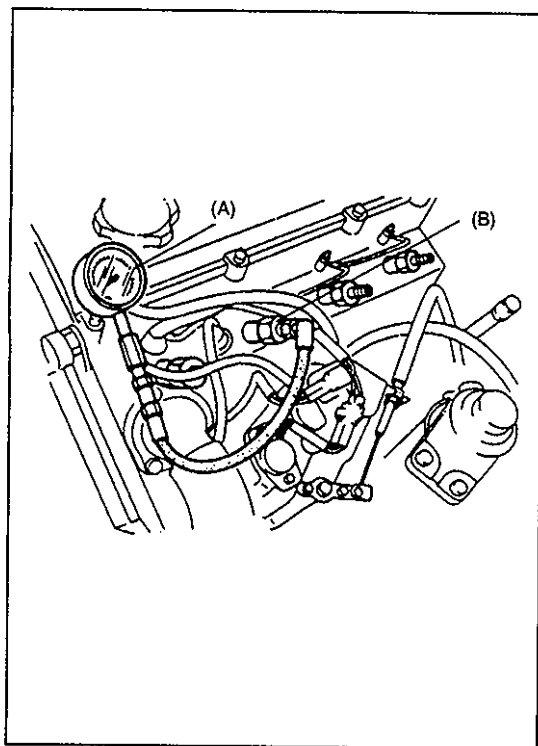

- 9) If compression in one or more cylinders is low, pour a small amount of engine oil into the cylinder and recheck compression.

- If compression increases, piston, piston rings or cylinder wall may be worn.
- If compression stays low, valve may be stuck or seating improperly.
- If compression in adjacent cylinders stays low, cylinder head gasket may be damaged or cylinder head distorted.

- 10) Removal special tool and install all fuel injection pipes, nozzles, washers and corrugate washers.
- 11) Install intercooler.
- 12) Connect spill valve connector.

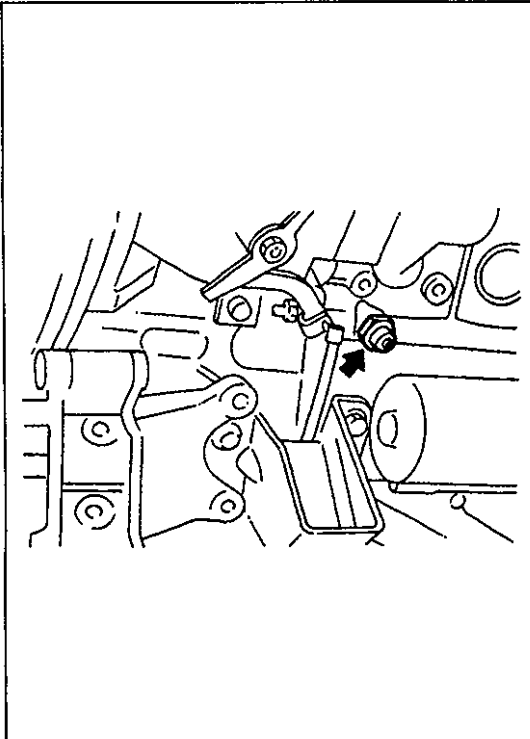

## OIL PRESSURE CHECK

### CAUTION:

Prior to checking oil pressure, check following items.

- Oil level in oil pan
- Oil quality
- Oil leaks

### WARNING:

When engine and engine oil are hot, they can badly burn. Don't burn yourself with either.

- 1) Remove oil pressure switch from cylinder block.

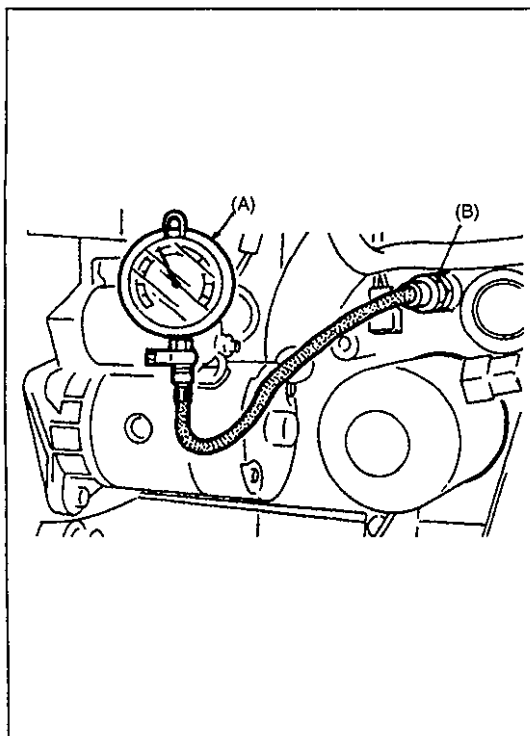

- 2) Install special tool to oil pressure switch hole.

### Special Tool

(A): 09915-77310

(B): 09915-78210

- 3) Start engine and warm it up to normal operating temperature.
- 4) After warming up, raise engine speed to 3,000 rpm and measure oil pressure.

### Oil pressure specification:

350 kPa (3.5 kg/cm<sup>2</sup>, 11 psi)

- 5) Stop engine and remove oil pressure gauge.

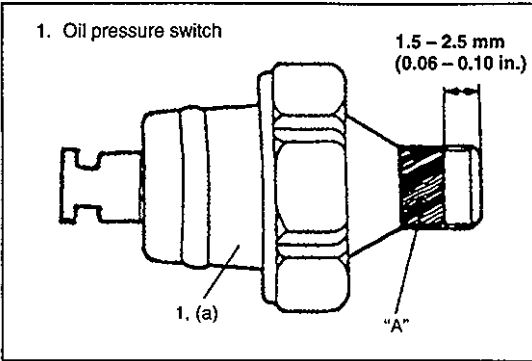

6) Before reinstalling oil pressure switch, be sure to wrap its screw threads with sealant and tighten switch to specified torque.

“A”: SUZUKI BOND 1207C, 99000-31150

**Tightening Torque**

(a): 15 N·m (1.5 kg-m, 11 lb-ft)

7) Start engine and check oil pressure switch for oil leakage.

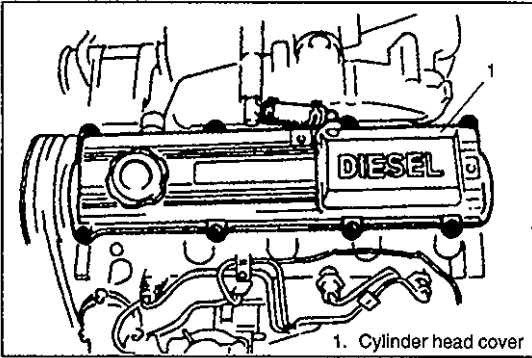

**VALVE LASH (CLEARANCE)**

- 1) Remove cylinder head cover.
- 2) Remove RH timing belt cover.

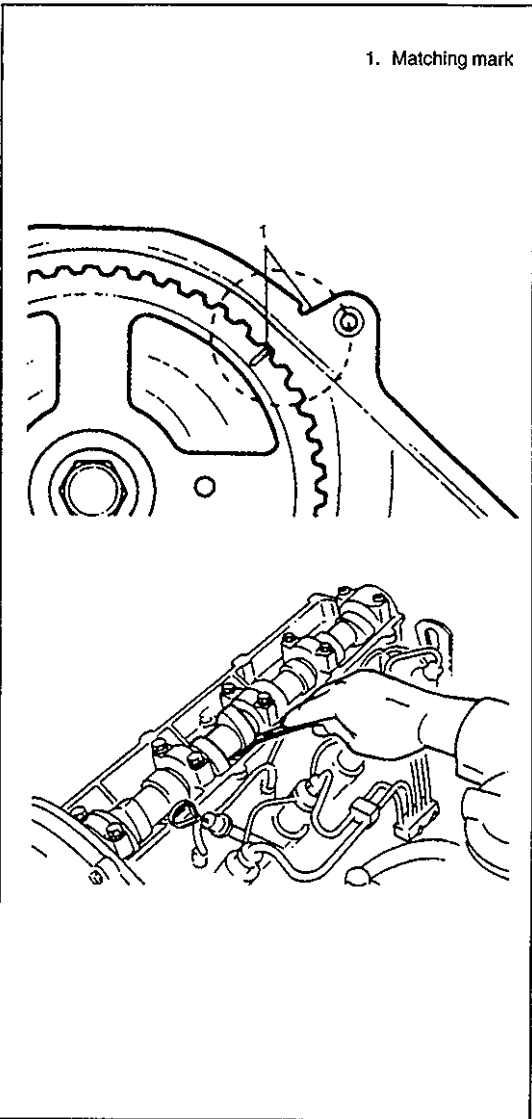

- 3) Set No.1 cylinder to compression TDC.
- 4) Measure valve clearance at No.1, No.2 (intake), and No.1, No.3 (exhaust) cylinders.

○: Adjustable

	No.1		No.2		No.3		No.4	
	IN	EX	IN	EX	IN	EX	IN	EX
No.1 cylinder compression TDC	○	○	○			○		
No.1 cylinder exhaust TDC				○	○		○	○

**Valve clearance (Engine Cold):**

IN: 0.25 ± 0.05 mm (0.010 ± 0.002 in.)

EX: 0.35 ± 0.05 mm (0.014 ± 0.002 in.)

**Reference:**

**Valve clearance (Engine Hot):**

IN: 0.30 mm (0.012 in.)

EX: 0.40 mm (0.016 in.)

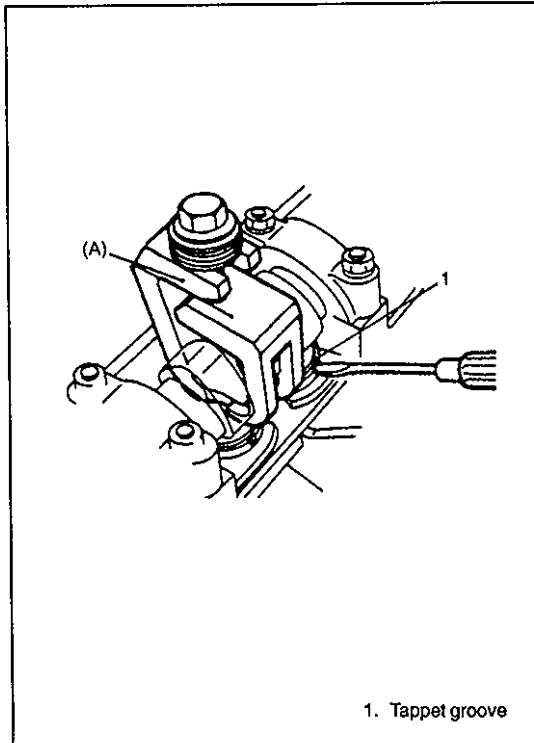

- 5) If valve clearance is not within the specification adjust valve clearance.
- i) Face intake cam lobe straight upward.
  - ii) Move tappet so that its notch is at manifold side.
  - iii) Press tappet down until adjustment disk is accessible with special tool.

#### Special Tool

(A): 09916-67810

- iv) Take out adjustment disk.
- v) Select an appropriate disk depending on valve clearance measured, and install it.

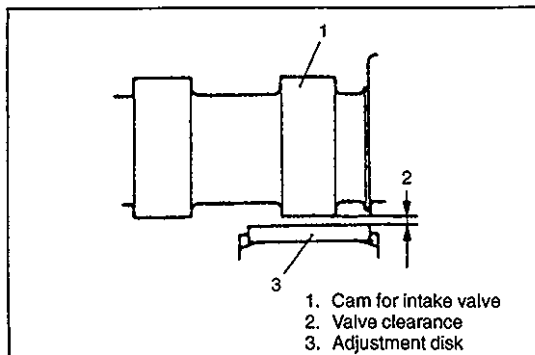

#### CAUTION:

- Disk thickness is indicated by the number marked on disk.
- Adjustment disks are available with 37 different thickness from 3.40 mm (0.13 in.) to 4.60 mm (0.18 in.).

- 6) Install cylinder head cover.

**Tightening Torque for Cylinder Head Cover Bolt:**  
10 N·m (1.0 kg-m, 7 lb-ft)

## REPAIR

### AIR CLEANER ELEMENT

#### REMOVAL

Remove air cleaner element from case.

#### INSTALLATION

For installation, reverse removal procedure.

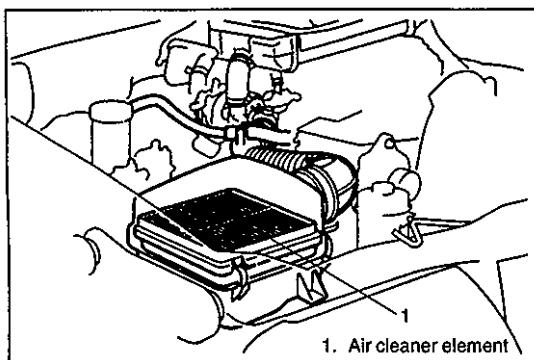

#### CLEAN

Blow off dust by compressed air from air outlet side of element.

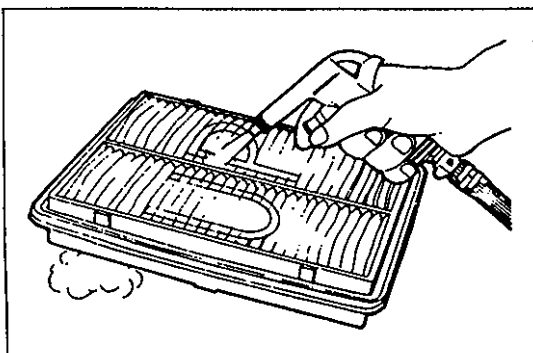

# INTAKE AND EXHAUST SYSTEM

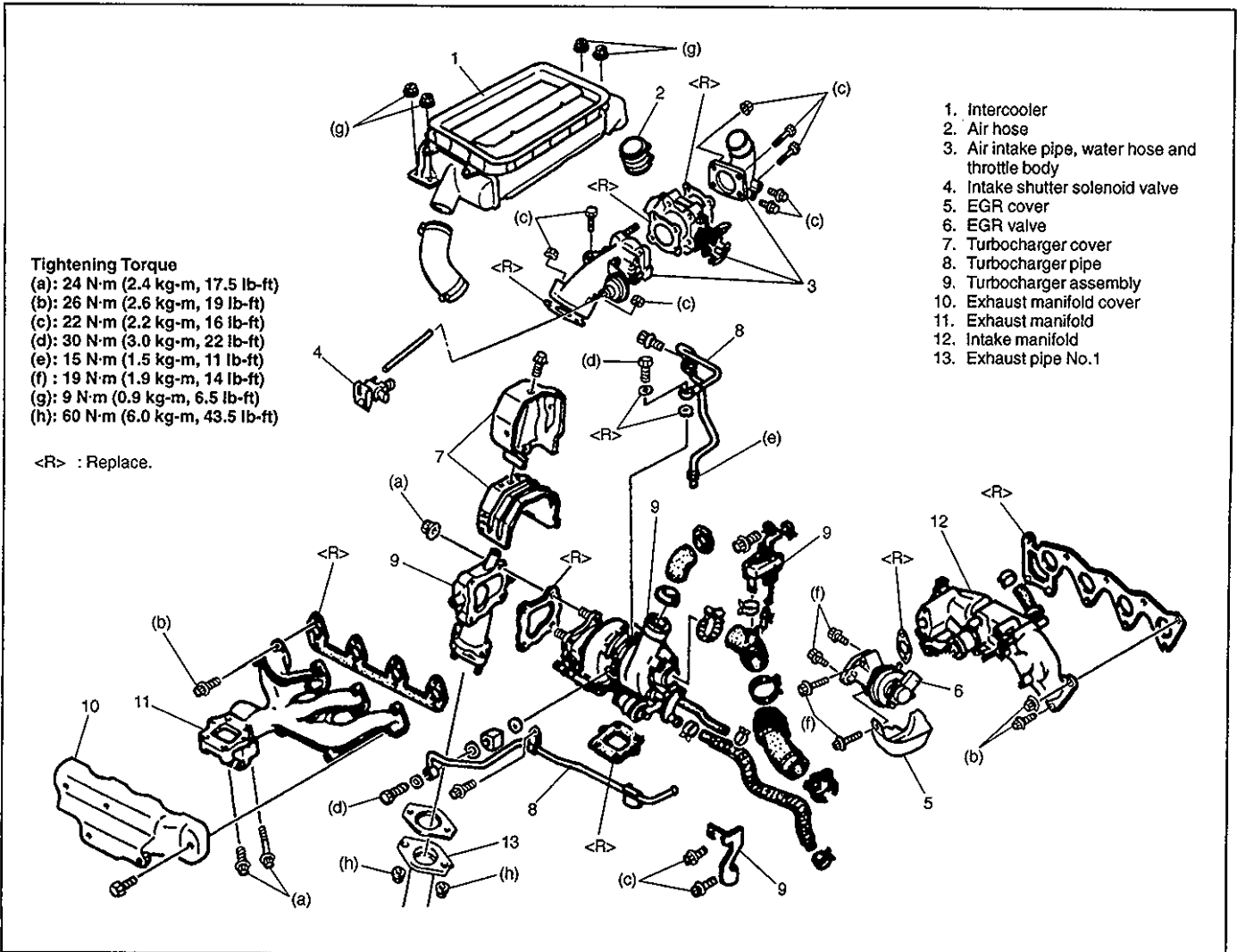

## REMOVAL/INSTALLATION

Remove in order shown in figure above.

For installation, reverse removal procedure and noting followings.

- Be careful of following points after turbocharger removal.
  - Do not hold actuator rod or hose when carrying turbocharger.
  - Cover turbocharger air inlet/outlet, exhaust inlet/outlet to prevent dirt or other material from entering.
  - Use specified new studs when installing turbocharger.
  - Idle engine for over 10 sec. after it is started. Rapid increase in engine speed can damage metal part of the turbocharger.
  - Because turbocharger rotates at high speed and high temperature, do not allow foreign material from entering the oil line and deformation of the oil pipe.
  - Avoid sudden engine racing and acceleration just after the engine is started or when vehicle has not been driven for extended period.
- After installation, verify that there is no fuel leakage, coolant leakage, oil leakage and exhaust gas leakage at each connection.

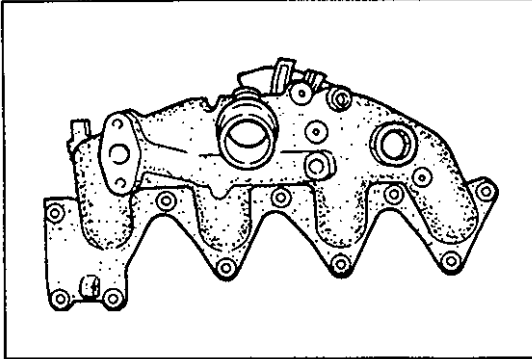

## INSPECTION

### Intake Manifold

- Check for damage and cracks.

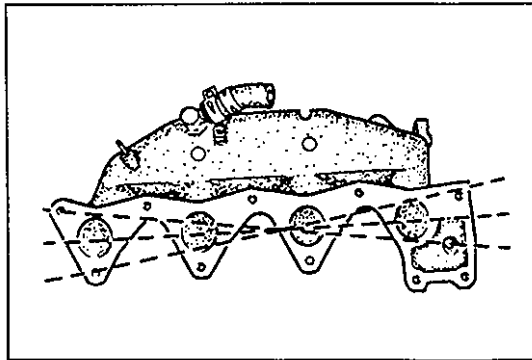

- Check flatness of intake manifold contact surface as shown.

**Distortion: 0.30 mm (2.17 in.) max.**

Replace intake manifold, if necessary.

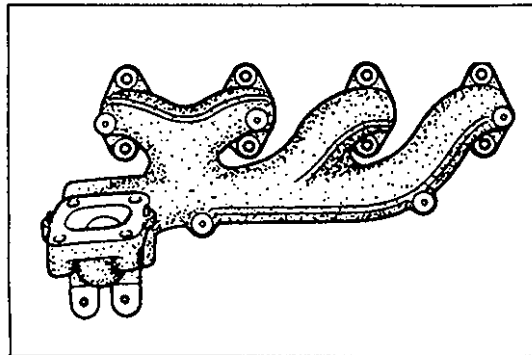

### Exhaust Manifold

- Check for damage and cracks.

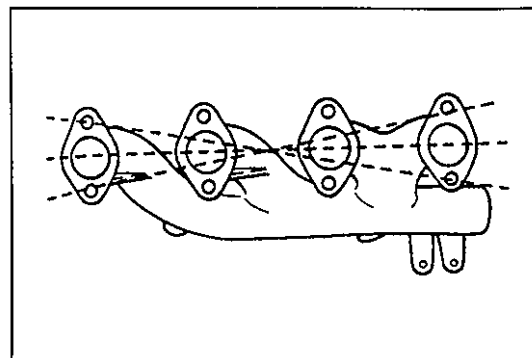

- Check flatness of exhaust manifold contact surface as shown.

**Distortion: 0.30 mm (2.17 in.) max.**

Replace exhaust manifold, if necessary.

### Turbocharger

Refer to SECTION 6E3.

### Wastegate Valve

Refer to SECTION 6E3.

## TIMING BELT, PULLEY AND BELT TENSIONER

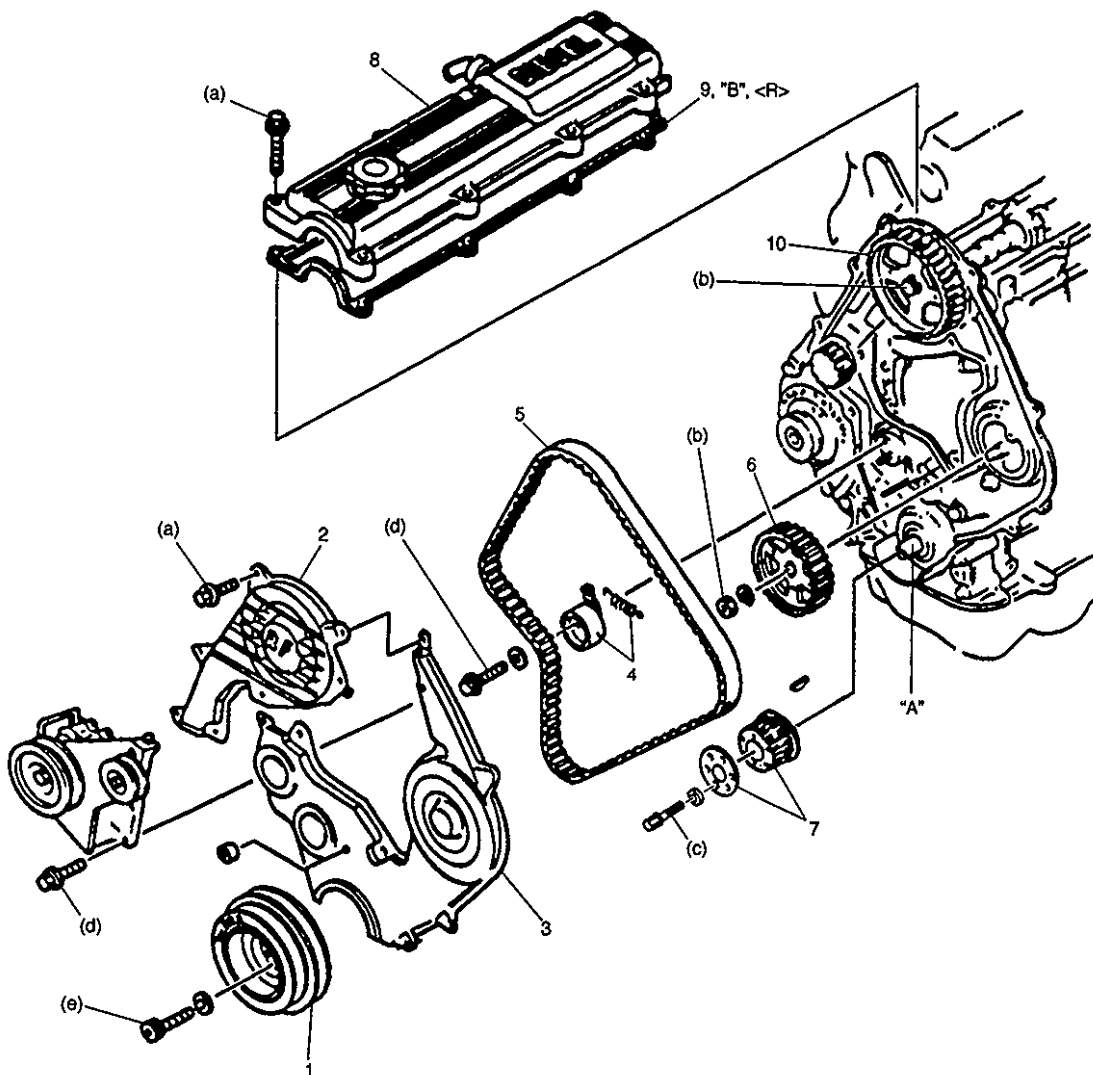

- |                                     |  |
|-------------------------------------|--|
| 1. Crankshaft pulley                | 6. Fuel injection pump pulley            |
| 2. Timing belt right cover          | 7. Timing belt crank pulley, guide plate |
| 3. Timing belt left cover           | 8. Cylinder head cover                   |
| 4. Timing belt tensioner and spring | 9. Gasket                                |
| 5. Timing belt                      | 10. Camshaft pulley                      |

**Tightening Torque**

- (a): 10 N·m (1.0 kg-m, 7 lb-ft)  
 (b): 60 N·m (6.0 kg-m, 43.5 lb-ft)  
 (c): 175 N·m (17.5 kg-m, 126.5 lb-ft)  
 (d): 40 N·m (4.0 kg-m, 29 lb-ft)  
 (e): 28 N·m (2.8 kg-m, 20 lb-ft)

"A" : Apply engine oil.

"B" : Apply SUZUKI BOND No. 1207C, 99000-31150.

<R>: Replace.

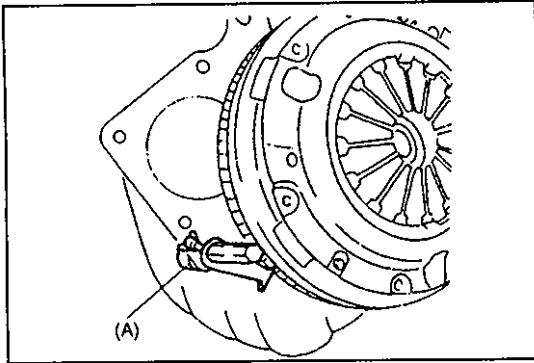

## REMOVAL

### Crankshaft Pulley

- 1) Hold drive plate by using special tool.

#### Special Tool

(A): 09924-17810

- 2) Loosen pulley lock bolt.
- 3) Remove crankshaft pulley and plate.

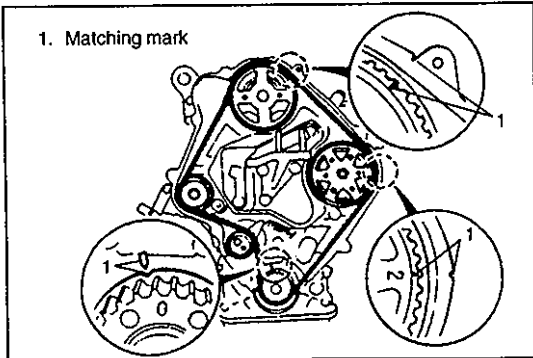

### Timing Belt

- 1) Turn crankshaft clockwise and align each pulley to the respective alignment mark.

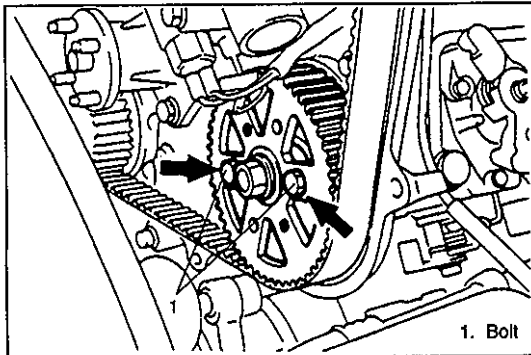

- 2) Insert two bolts (M8 × 1.25) in fuel injection pump pulley as shown, fastened to fuel injection pump bracket threads, so that pulley is fixed.

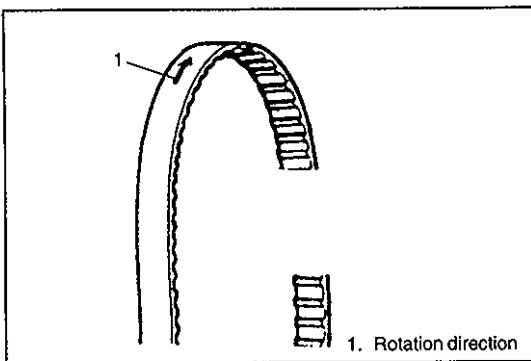

#### NOTE:

When reusing timing belt, it must be reinstalled in the same direction as it is before removal. For this purpose, be sure to mark rotation direction on belt before removing it.

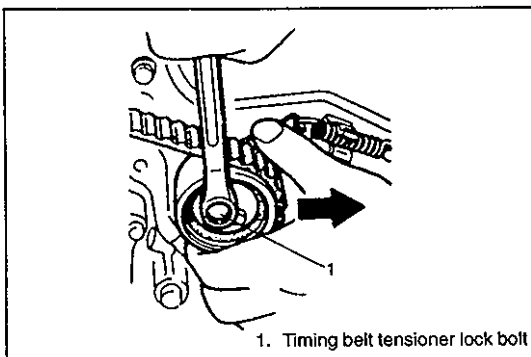

- 3) Loosen belt tensioner lock bolt and pull tensioner lever fully inward by hand. In this condition, tighten lock bolt.

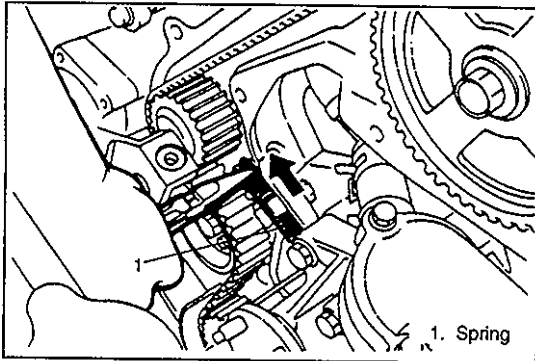

- 4) Remove tensioner spring from tensioner lever by using pliers.
- 5) Loosen belt tensioner lock bolt and remove timing belt from each pulley.

**CAUTION:**

Following will damage belt and shorten its life; Forcefully twisting it, turning it inside out, bending it, or allowing oil or grease on it.

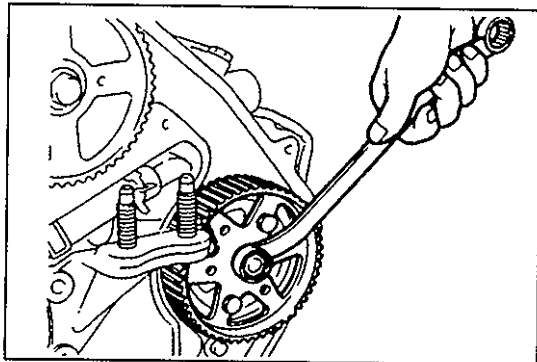

**Injection Pump Pulley**

- 1) Loosen injection pump pulley lock bolt.

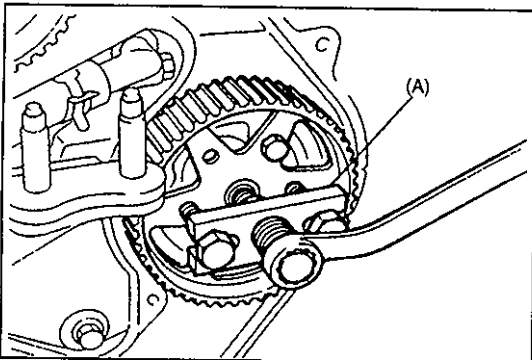

- 2) Separate injection pump pulley from injection pump shaft by using special tool.

**Special Tool**

**(A): 09944-36011**

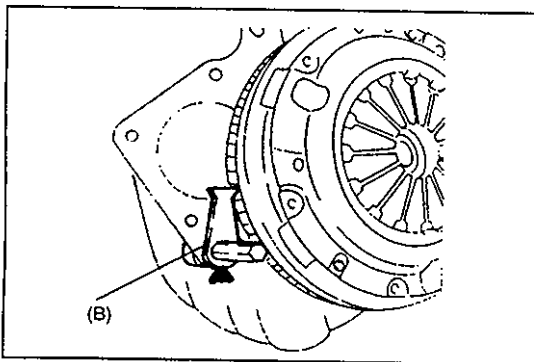

**Timing Belt Pulley**

- 1) Hold flywheel by using special tool.
- 2) Remove timing belt pulley lock bolt.

**Special Tool**

**(B): 09924-17810**

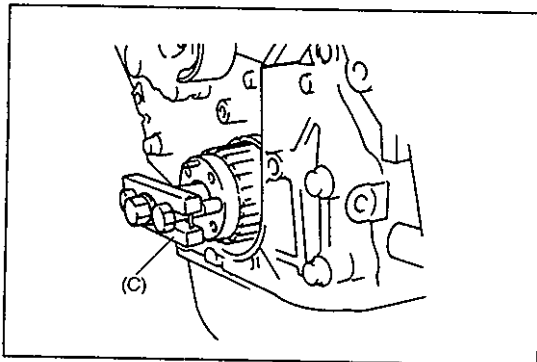

- 3) Install special tool to timing belt pulley.

**Special Tool**

**(C): 09944-36011**

- 4) Remove timing belt pulley.

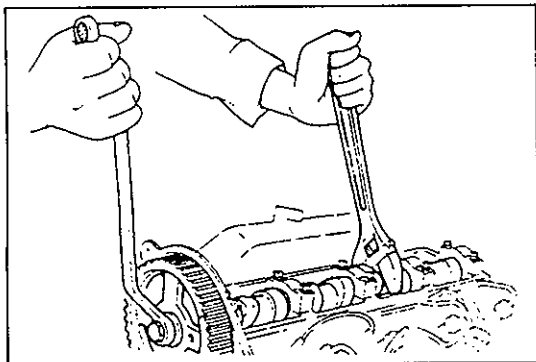

### Camshaft Pulley

- 1) Hold camshaft with a wrench and loosen camshaft pulley lock bolt.

**CAUTION:**

Do not damage cylinder head edge the wrench.

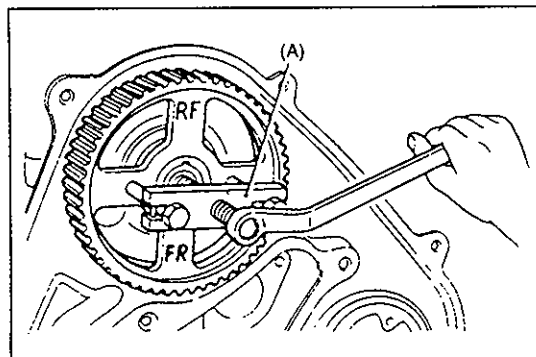

- 2) Separate camshaft pulley from camshaft with special tool.

**Special Tool**

(A): 09944-36011

**CAUTION:**

Do not hit camshaft pulley with a hammer.

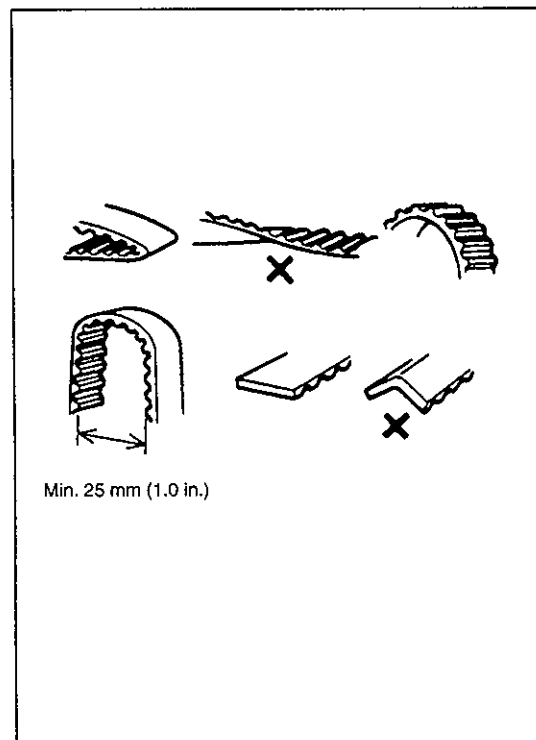

### INSPECTION

#### Timing Belt

Visually check the timing belt for cracks, damage, and wear. Replace if necessary.

**CAUTION:**

Following will damage the belt and shorten its life; Forcefully twisting it, turning it inside out, bending it, or allowing oil or grease on it.

Timing belt replacement intervals:

Refer to SECTION 0B.

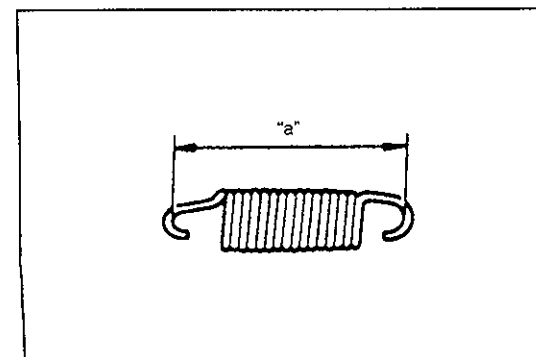

#### Tensioner Spring

Measure tensioner spring free length. Replace spring if it is excessively extended.

Free Length "a": 52.6 mm (2.07 in.)

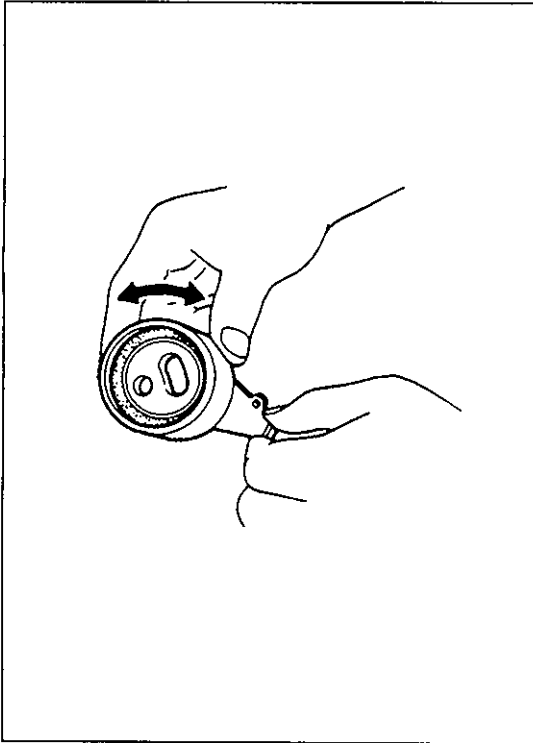

**Tensioner**

- 1) Rotate tensioner by hand and check if it turns smoothly without abnormal noise and looseness. Replace if necessary.
- 2) Visually check tensioner for grease leakage. Replace if necessary.

**CAUTION:**

Do not clean tensioner with cleaning fluids or a steam cleaner. If necessary, use a soft rag to wipe it clean, and avoid scratching it.

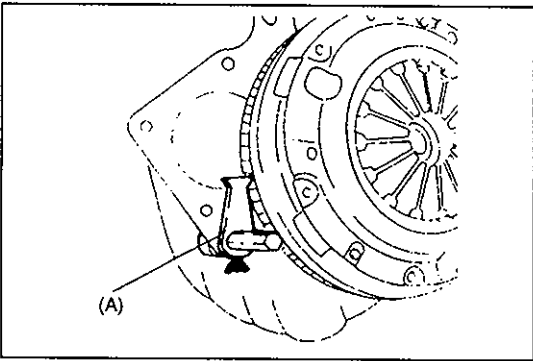

**INSTALLATION**

**Timing Belt Pulley**

- 1) Hold flywheel by using special tool.

**Special Tool**

**(A): 09924-17810**

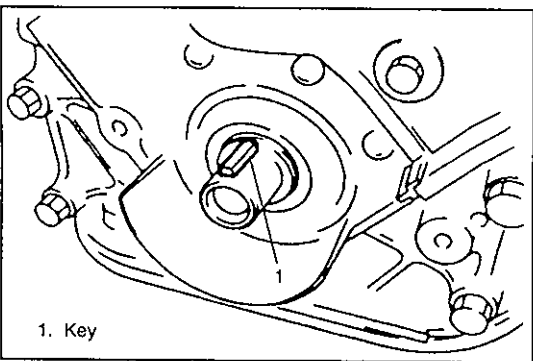

- 2) Install timing belt pulley key.
- 3) Install timing belt pulley.

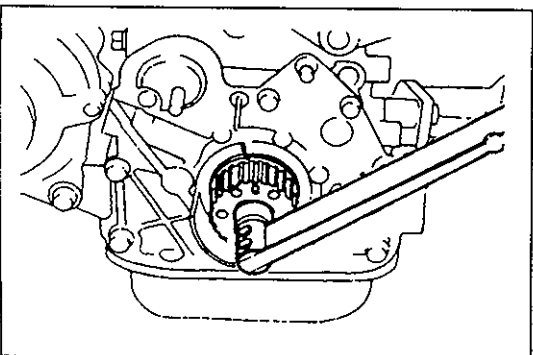

- 4) Tighten timing belt pulley lock bolt.

**Tightening Torque for Lock Bolt:**

**175 N·m (17.5 kg-m, 126.5 lb-ft)**

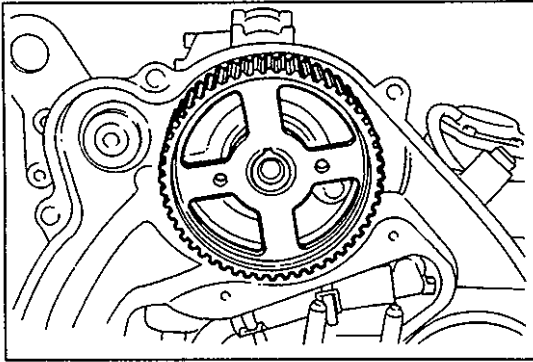

### Camshaft Pulley

- 1) Connect camshaft pulley onto camshaft with semicircular (woodruff) key.

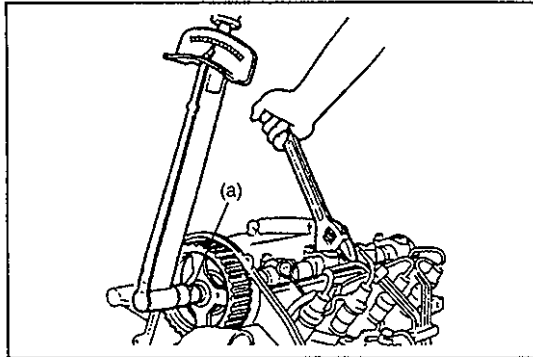

- 2) Hold camshaft with a suitable wrench, and tighten camshaft pulley lock bolt.

### Tightening Torque

(a): 60 N·m (6.0 kg·m, 43.5 lb·ft)

### CAUTION:

Do not damage cylinder head edge the wrench.

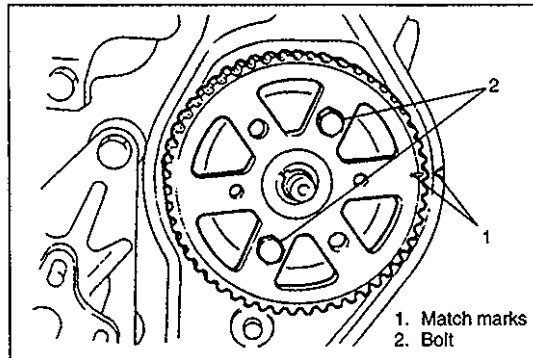

### Injection Pump Pulley

- 1) Install injection pump pulley with semicircular (woodruff) key to injection pump shaft.
- 2) Rotate injection pump pulley until timing marks are aligned.
- 3) Insert two bolts (M8 × 1.25) in injection pump pulley as shown, fastened to injection pump bracket threads, so that pulley is fixed.

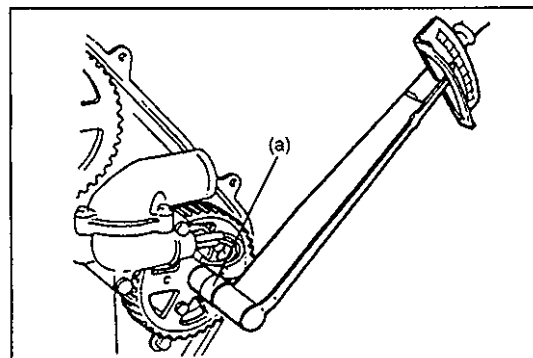

- 4) Tighten lock nut to specified torque.

### Tightening Torque

(a): 60 N·m (6.0 kg·m, 43.5 lb·ft)

- 5) Remove two bolts (M8 × 1.25) in injection pump pulley.

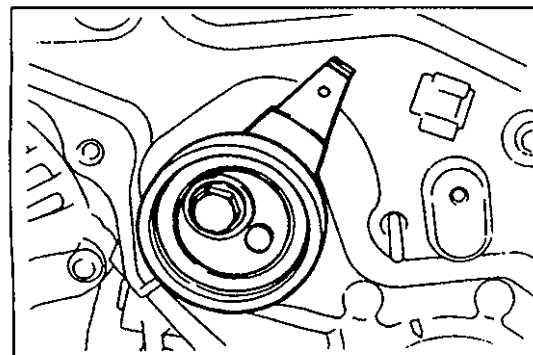

### Tensioner

- 1) Install tensioner spring onto the tensioner.
- 2) Install tensioner assembly.
- 3) Temporarily secure it so tensioner is shifted outward.

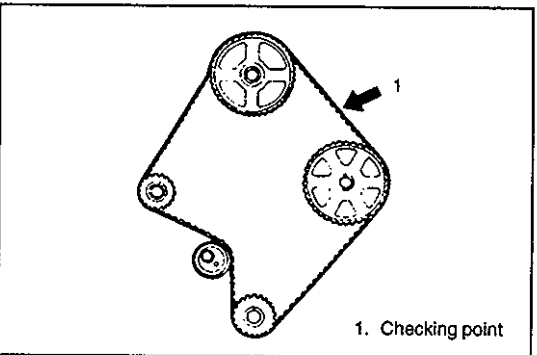
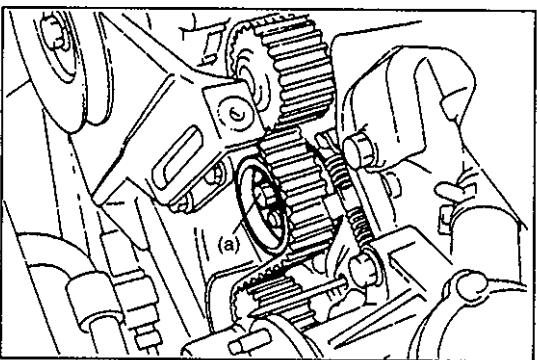
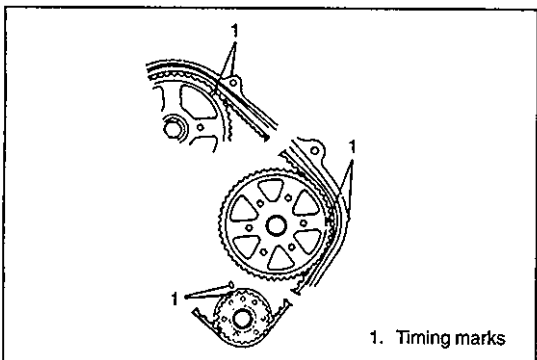
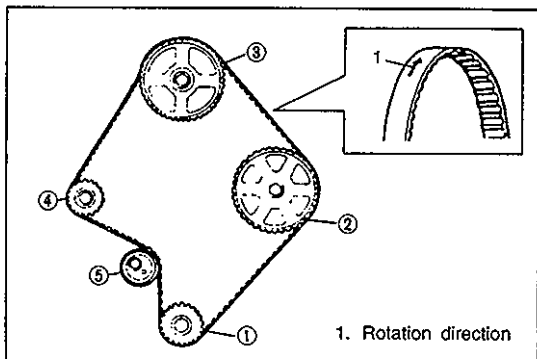
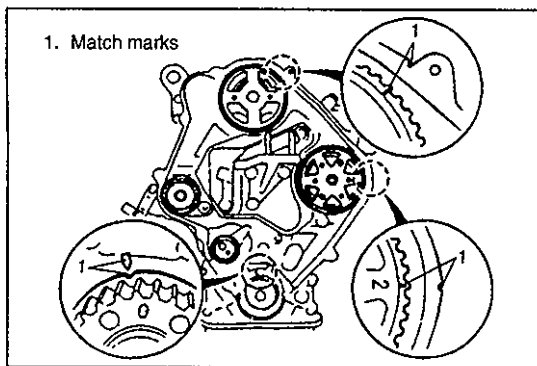

## Timing Belt

1) Check that timing marks of timing belt pulley, camshaft pulley and injection pump pulley align with timing marks on seal plate.

2) Install timing belt in sequence shown in figure.

### CAUTION:

Timing belt must be reinstalled in same direction of rotation for continued durability.

3) Remove two affixing bolts from injection pump pulley.

4) Loosen tensioner lock bolt.

5) Turn crankshaft twice in the direction of rotation (clockwise).

### CAUTION:

Do not rotate in reverse direction.

6) Check that each timing mark is correctly aligned. If not aligned, remove timing belt. Repeat steps 1) – 5).

7) Tighten timing belt tensioner lock bolt.

### Tightening Torque

(a): 40 N·m (4.0 kg·m, 29 lb·ft)

8) Check timing belt tension.

If tension is not correct, loosen tensioner lock bolt and repeat steps 5) – 7), or replace tensioner spring.

**Standard deflection: 9.0 – 11.5 mm (0.36 – 0.45 in.)**  
(by applying force of 98 N (10 kg, 22 lb))

### CAUTION:

Be sure not to apply tension other than that of tensioner spring.

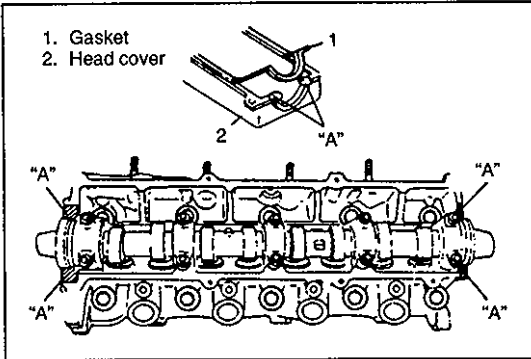

### Cylinder Head Cover

- 1) Apply sealant to shaded areas "A" as shown in figure.
- 2) Install cylinder head cover.

"A": SUZUKI BOND No. 1207C, 99000-31150

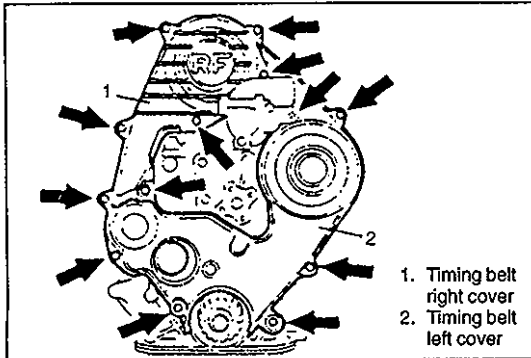

### Timing Belt Cover

Install left and right timing belt cover.

**Tightening Torque for Timing Belt Cover Bolt**  
10 N·m (1.0 kg-m, 7 lb-ft)

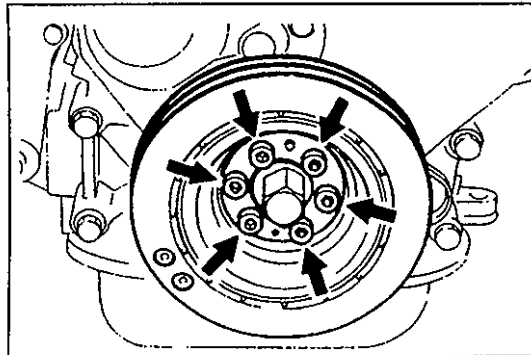

### Crankshaft Pulley

Install crankshaft pulley.

**Tightening Torque for Crankshaft Pulley Bolt**  
28 N·m (2.8 kg-m, 20 lb-ft)

# VALVE, CYLINDER HEAD AND CAMSHAFT

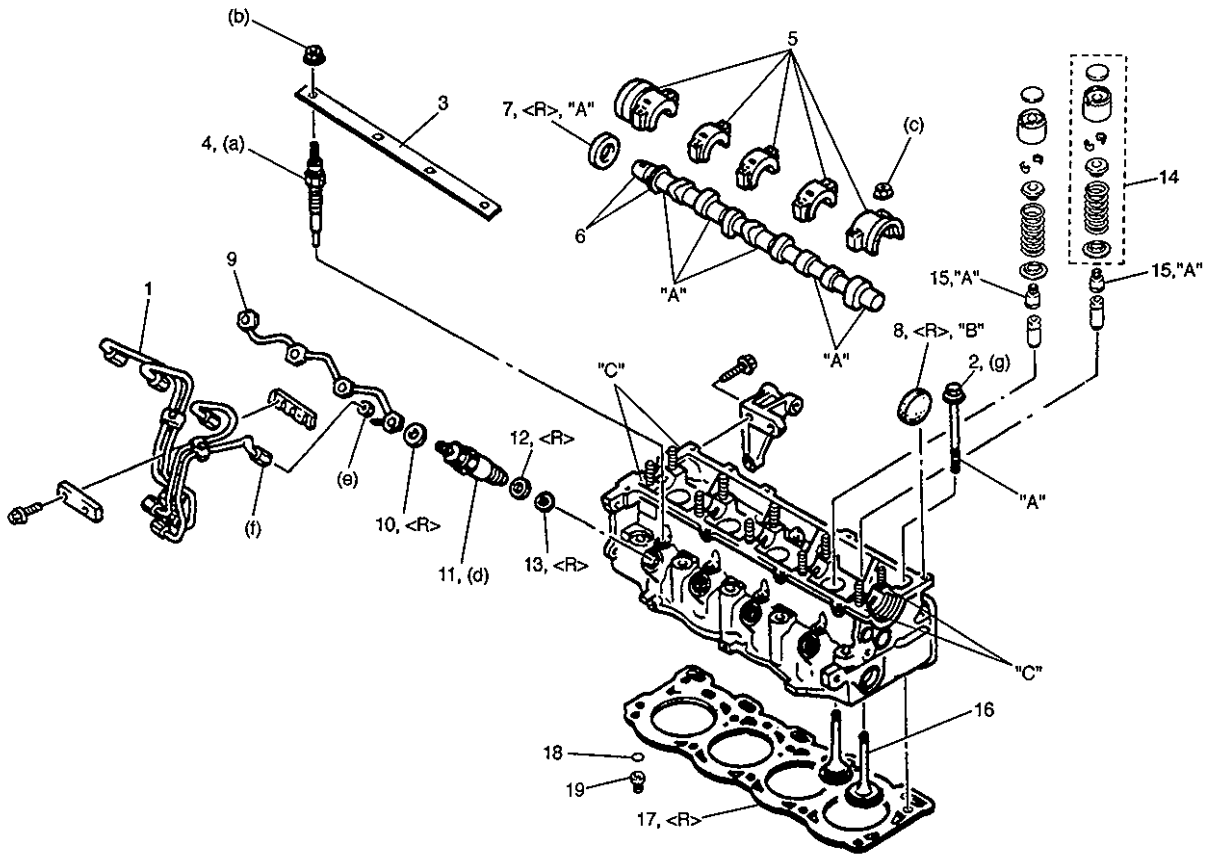

- 1. Fuel injection pipe
- 2. Cylinder head bolt
- 3. Glow cord
- 4. Glow plug
- 5. Camshaft cap
- 6. Camshaft and oil seal
- 7. Oil seal
- 8. Cap
- 9. Fuel leak pipe

- 10. Gasket
- 11. Injection nozzle
- 12. Washer
- 13. Gasket
- 14. Adjusting disk, tappet, valve cotter, valve spring, valve spring seat
- 15. Valve seal
- 16. Valve
- 17. Cylinder head gasket
- 18. O-ring
- 19. Oil control plug

**Tightening Torque**

- (a): 18 N·m (1.8 kg-m, 13 lb-ft)
- (b): 10 N·m (1.0 kg-m, 7 lb-ft)
- (c): 24 N·m (2.4 kg-m, 17.5 lb-ft)
- (d): 65 N·m (6.5 kg-m, 47 lb-ft)
- (e): 38 N·m (3.8 kg-m, 27.5 lb-ft)
- (f): 28 N·m (2.8 kg-m, 20 lb-ft)
- (g): 30 N·m (3.0 kg-m, 21.5 lb-ft)

"A" : Apply engine oil.

"B" : Apply sealant SUZUKI BOND No. 1207C, 99000-31150.

"C" : Apply sealant SUZUKI BOND No. 1215, 99000-31110.

<R>: Replace.

**REMOVAL**

Remove in order shown in the figure on previous page, and note following points.

- Drain engine coolant.
- Drain engine oil.
- Remove fuel tank cap to release vapor pressure.

**Injection Pump Pulley**

Refer to "Removal" of "Injection Pump Pulley" under "Timing Belt, Pulley and Belt Tensioner" earlier in this section.

**Camshaft Pulley**

Refer to "Removal" of "Camshaft Pulley" under "Timing Belt, Pulley and Belt Tensioner" earlier in this section.

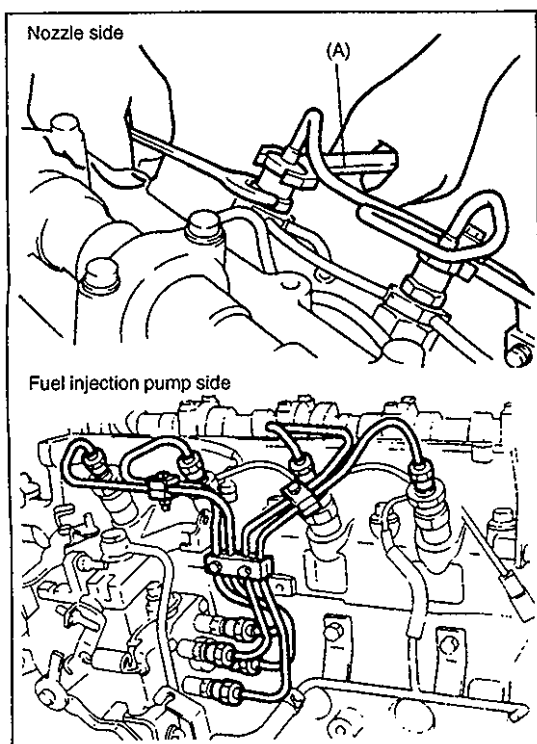
**Injection Pipe**

Remove injection pipes shown in figure.

**CAUTION:**

Cover outlet of injectors with a rag to catch released fuel.

**Special Tool**

(A): 09950-76010

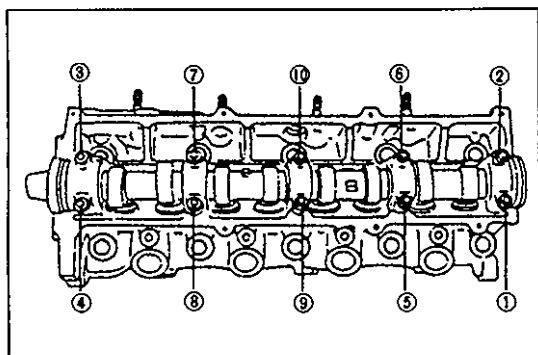
**Camshaft Cap**

- 1) Loosen camshaft cap bolts in two or three steps in order shown in figure.
- 2) Remove camshaft caps.
- 3) Remove camshaft.
- 4) Remove camshaft oil seals from camshaft.

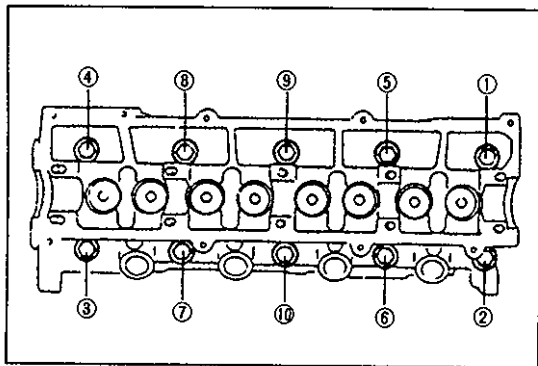

### Cylinder Head Bolt

- 1) Loosen cylinder head bolts in two or three steps in order shown in figure.
- 2) Remove cylinder head bolts.

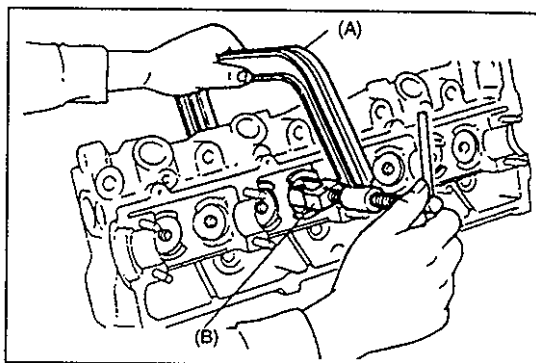

### Valve Keeper

- 1) Set special tool against upper valve spring seat as shown in figure.
- 2) Compress spring and remove valve keepers.

#### Special Tool

(A): 09916-14510

(B): 09916-48210

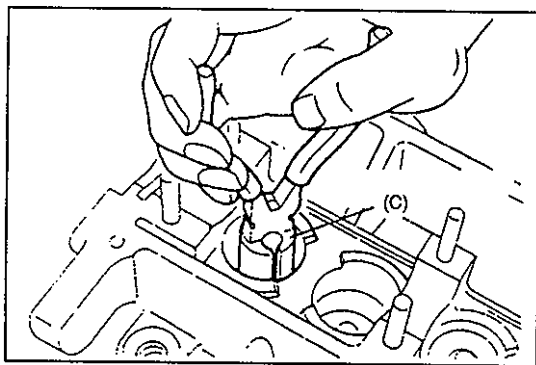

### Valve Seal

Remove valve seal by using special tool.

#### Special Tool

(C): 09916-47810

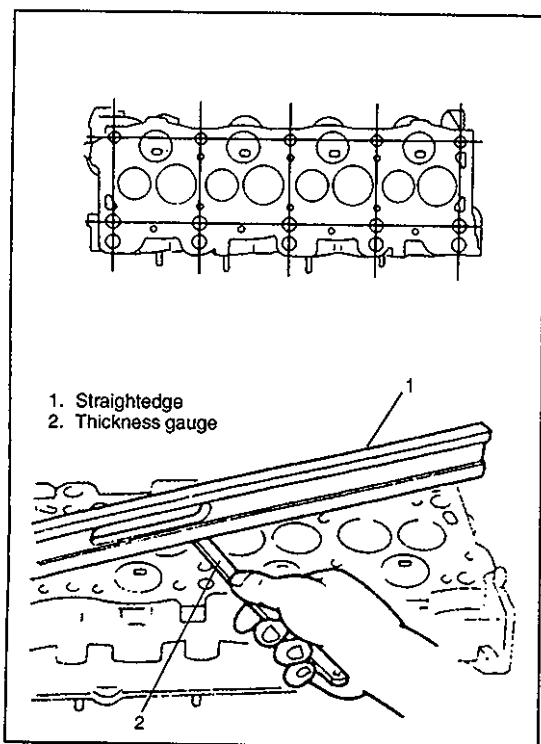

### INSPECTION

#### Cylinder Head

- 1) Inspect cylinder head for damage, cracks, and leakage of water and oil. Replace if necessary.
- 2) Using a straightedge, measure cylinder head for distortion in seven directions shown in the figure.

**Distortion: 0.10 mm (0.004 in.) max.**

If cylinder head distortion exceeds specification, replace cylinder head.

#### CAUTION:

Do not attempt to repair a cylinder head by milling or grinding.

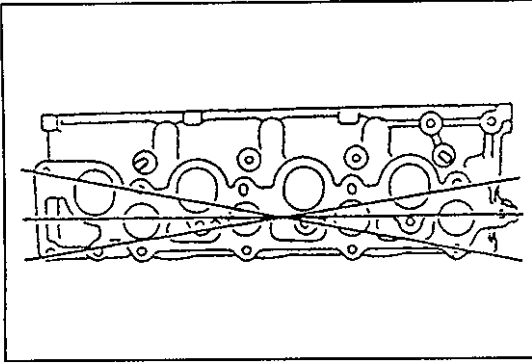

- 3) Using a straightedge, measure manifold contact surfaces for distortion in six directions shown in figure.

**Distortion: 0.20 mm (0.008 in.) max.**

If distortion exceeds specification, grind the surface or replace cylinder head.

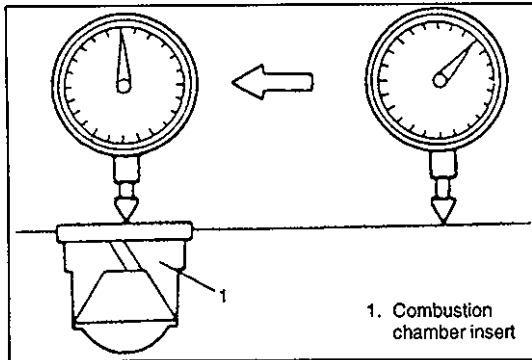

### Combustion Chamber Insert

- 1) Inspect combustion chamber insert for damage or crack, replace if necessary.
- 2) Measure recessed or projected amount of combustion chamber insert from cylinder head surface.

**Recession: 0.020 mm (0.0008 in.) max.**

**Projection: 0.005 mm (0.0001 in.) max.**

If it exceeds specification, replace the combustion chamber insert and cylinder head as an assembly.

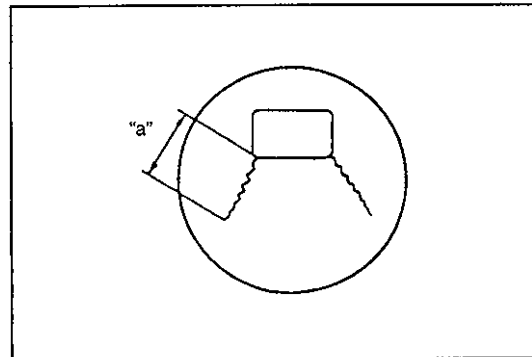

- 3) Measure length of cracks at injection port.

**Crack length "a": 10 mm (0.39 in.) max.**

If crack length exceeds maximum, replace cylinder head.

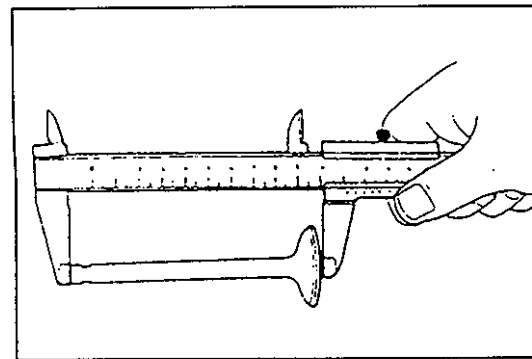

- 4) Measure length of each valve and replace valves as necessary.

### Length:

**Standard IN : 106.9 mm (4.209 in.)**

**EX: 106.8 mm (4.205 in.)**

**Minimum IN : 106.4 mm (4.189 in.)**

**EX: 106.3 mm (4.185 in.)**

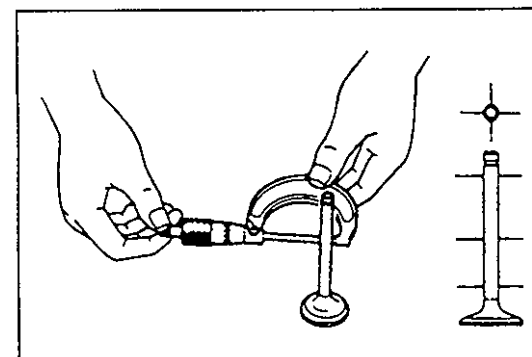

- 5) Measure diameter of each valve stem and replace valve as necessary.

### Diameter:

**Standard IN : 7.970 – 7.985 mm (0.3138 – 0.3143 in.)**

**EX: 7.965 – 7.980 mm (0.3136 – 0.3141 in.)**

**Minimum IN : 7.920 mm (0.3118 in.)**

**EX: 7.915 mm (0.3116 in.)**

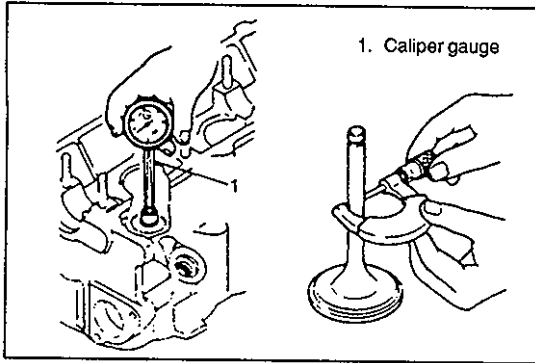

- 6) Calculate valve stem-to-guide clearance by subtracting outer diameter of valve stem from the inner diameter of corresponding valve guide.

**Clearance:**

**IN: 0.040 – 0.075 mm (0.0016 – 0.0029 in.)**

**EX: 0.045 – 0.080 mm (0.0018 – 0.0031 in.)**

If the clearance exceeds specifications, replace valve and/or valve guide.

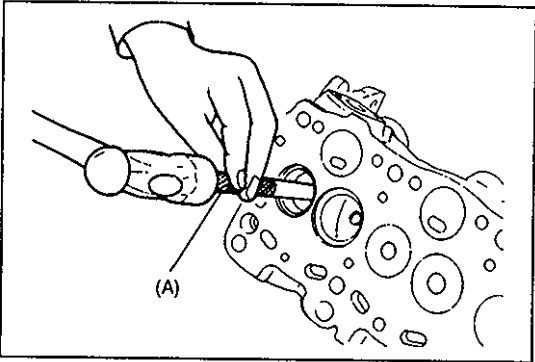

**Valve Guide**

- 1) Remove the valve guide from combustion chamber side by using special tool.

**Special Tool**

**(A): 09916-46010**

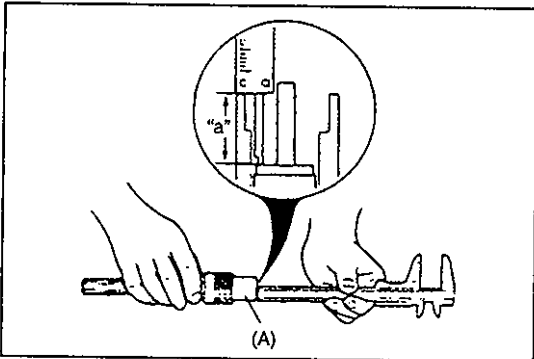

- 2) Assemble special tool so that depth "a" is as specified.

**Special Tool**

**(A): 09916-57810**

**Depth "a": 8.3 – 8.8 mm (0.327 – 0.346 in.)**

- 3) Tighten the lock nut.

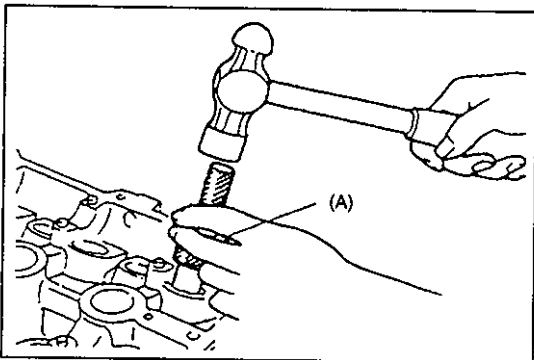

- 4) Tap the valve guide in from side opposite combustion chamber until special tool contacts cylinder head.

**Special Tool**

**(A): 09916-57810**

- 5) Verify that valve guide protrusion is within specifications.

**Valve guide protrusion:**

**8.3 – 8.8 mm (0.327 – 0.346 in.)**

If not within specifications, repeat steps 1) – 4).

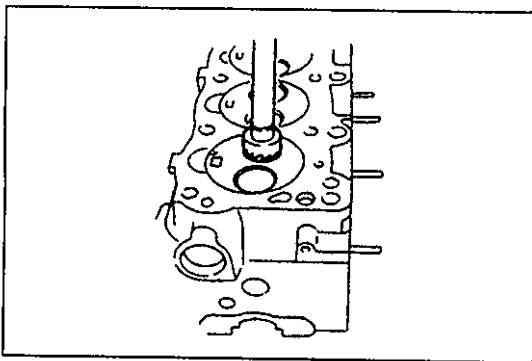

**Valve Seat**

- 1) Inspect contact surface of valve seat and valve face for following.

- Roughness
- Damage

If necessary, resurface valve seat to specified angle with valve seat cutter and/or resurface valve face.

**Angle: IN: 30°, EX: 45°**

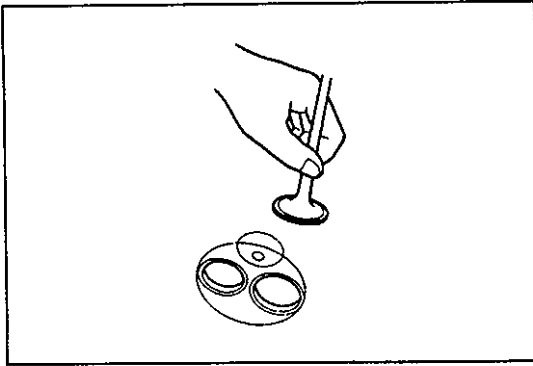

- 2) Apply a thin coat of Prussian Blue to valve face.
- 3) Check valve seating by pressing valve against the seat.
  - If blue does not appear 360° around valve face, replace valve.
  - If blue does not appear 360° around valve seat, resurface seat.

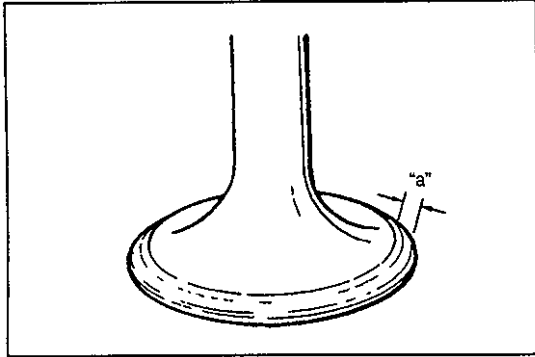

- 5) Measure seat contact width.

Width "a":

IN: 1.4 – 1.8 mm (0.056 – 0.070 in.)

EX: 1.64 – 2.04 mm (0.065 – 0.080 in.)

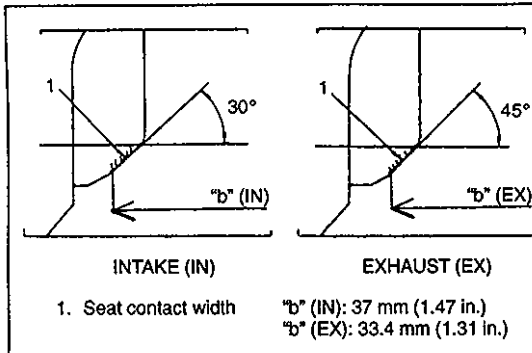

- 6) Verify that valve seating position is at the center of valve face.
  - If the seating position is too high, correct valve seat using 75° (IN) or 60° (EX) cutter, and 30° (IN) or 45° (EX) cutter.
  - If the seating position is too low, correct valve seat using 15° (IN) or 30° (EX) cutter, and 30° (IN) or 45° (EX) cutter.

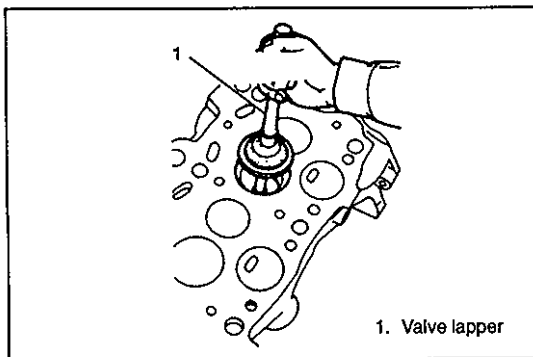

- 7) Set valve to the valve seat by using a lapping compound.

**CAUTION:**

Do not let compound adhere the valve stem.

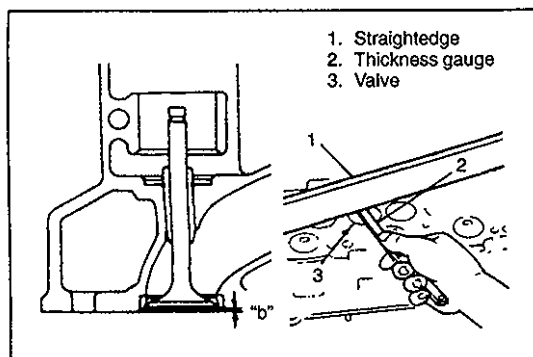

- 8) Measure receded amount from the cylinder head surface by using straightedge and thickness gauge. If receded amount exceeds 1.55 mm (0.061 in.), replace cylinder head.

Recession "b":

Standard: 0.75 – 1.05 mm (0.030 – 0.041 in.)

Maximum: 1.55 mm (0.061 in.)

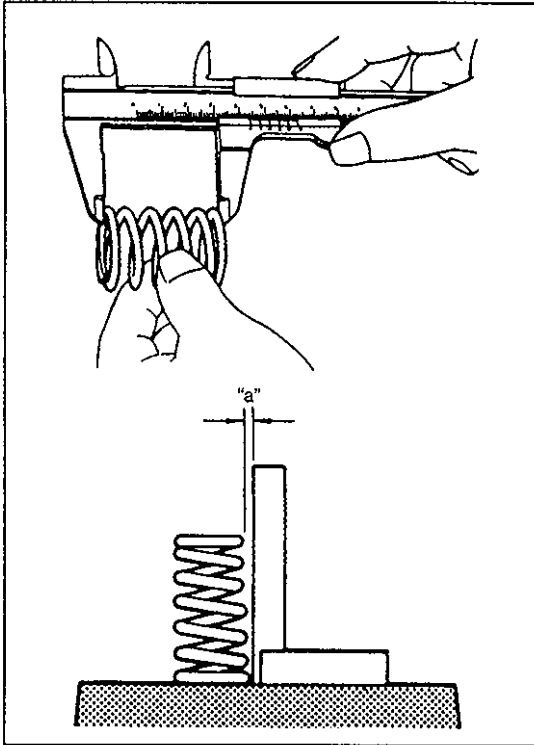

### Valve Spring

- 1) Inspect each valve spring for cracks or damage.
- 2) Measure free length and out-of square. Replace valve springs as necessary.

#### Free length:

**Standard: 45.11 mm (1.776 in.)**

**Minimum: 44.80 mm (1.764 in.)**

#### Out-of square "a":

**Maximum: 1.6 mm (0.063 in.)**

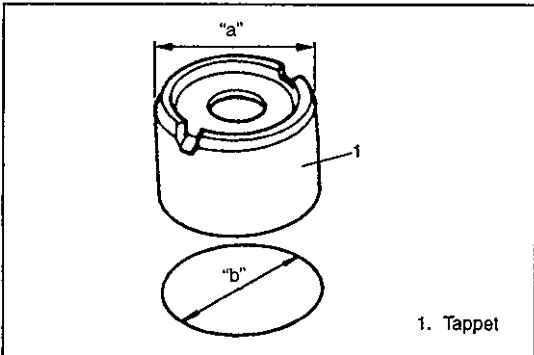

### Tappet

- 1) Check tappet-to-tappet hole clearance.
  - i) Measure tappet outer diameter.

#### Outer diameter "a":

**34.949 – 34.965 mm (1.37594 – 1.37657 in.)**

- ii) Measure inner diameter of tappet hole in cylinder head.

#### Inner diameter "b":

**34.990 – 35.010 mm (1.37756 – 1.37834 in.)**

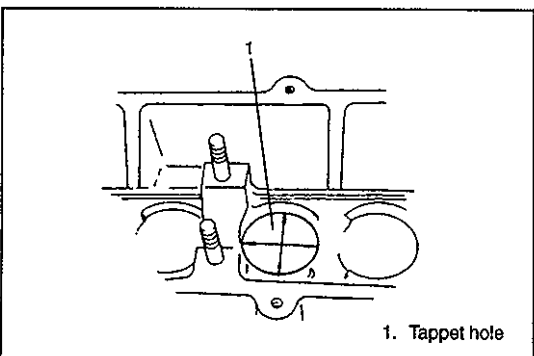

- 2) Calculate difference (clearance) between tappet outer diameter and hole inner diameter.

If clearance exceeds specification, replace tappet or the cylinder head.

#### Clearance:

**Standard: 0.025 – 0.061 mm (0.00099 – 0.00240 in.)**

**Maximum: 0.10 mm (0.004 in.)**

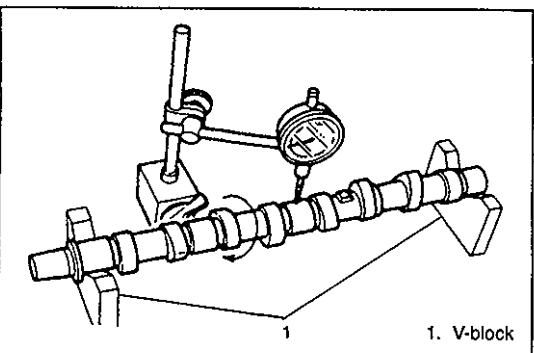

### Camshaft

- 1) Set front and rear journals on V-blocks.
- 2) Using a micrometer measure camshaft runout. Replace camshaft if necessary.

**Runout: 0.10 mm (0.004 in.) max.**

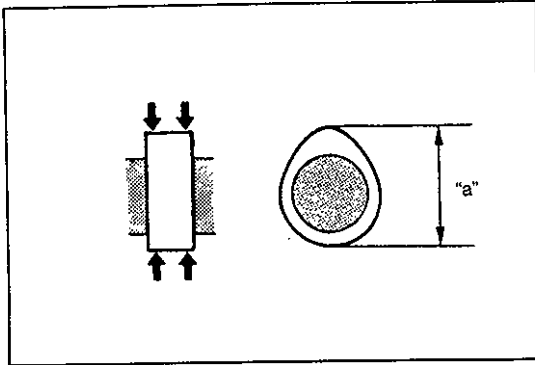

- 3) Inspect camshaft for wear and damage. Replace camshaft if necessary.
- 4) Measure each camshaft lobe height at point as shown.

#### Height "a":

IN	Standard	mm (in.)	43.792 (1.7241)
	Minimum	mm (in.)	42.110 (1.6579)
EX	Standard	mm (in.)	45.300 (1.7835)
	Minimum	mm (in.)	44.900 (1.7677)

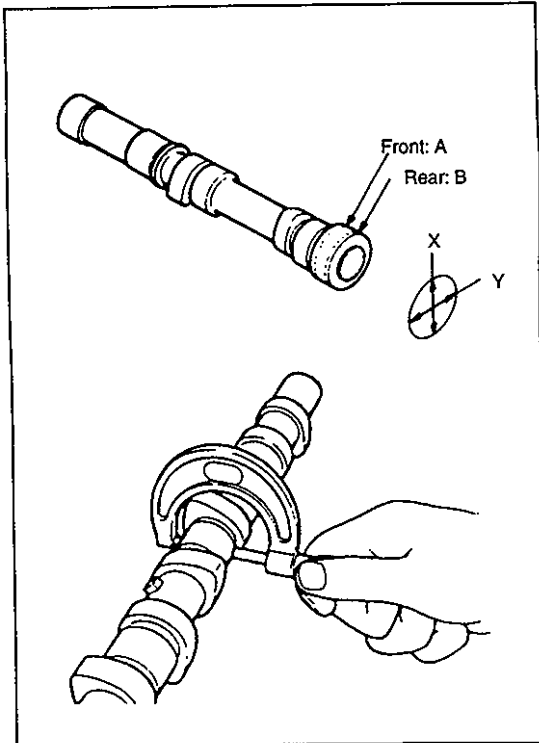

- 5) Measure journal diameters in X and Y directions at two points (A and B) as shown in the figure.

#### Diameter:

**31.959 – 31.975 mm (1.2583 – 1.2588 in.)**

#### Out-of-round:

**0.05 mm (0.002 in.) max.**

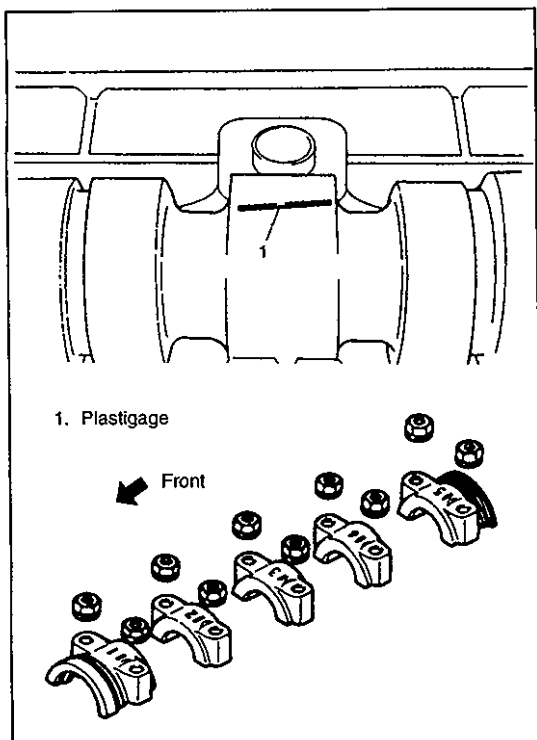

- 6) Measure camshaft journal oil clearances.

#### CAUTION:

**Do not install tappets and adjustment disks when measuring oil clearance.**

- i) Remove all foreign material and oil from journals and bearing surfaces.
- ii) Set camshaft onto cylinder head.
- iii) Position plastigage atop the journals in axial direction.
- iv) Install camshaft caps according to cap numbers as shown in figure.

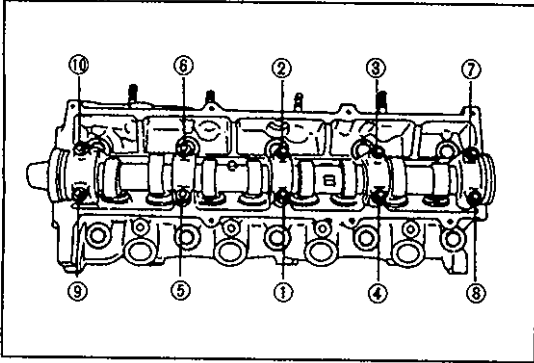

- v) Install camshaft cap nuts and tighten them in two or three steps in the order shown in figure.

**Tightening Torque for Camshaft Cap Nut**  
**24 N·m (2.4 kg-m, 17.5 lb-ft)**

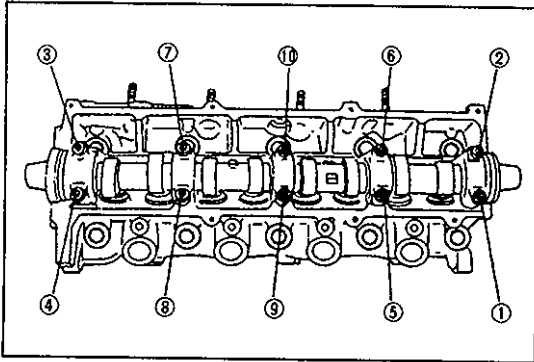

- vi) Loosen camshaft cap nuts in two or three steps in order shown in figure.
- vii) Remove camshaft caps.

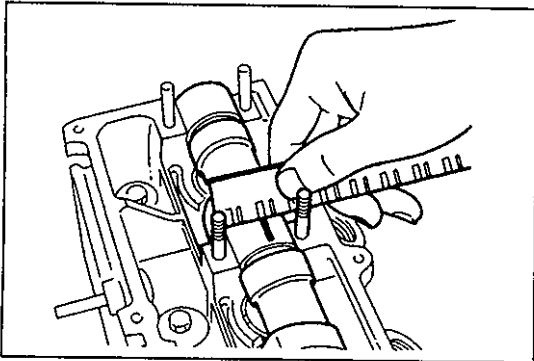

- viii) Measure oil clearances.

**Oil clearance:**

**Standard: 0.025 – 0.066 mm (0.010 – 0.0025 in.)**

**Maximum: 0.10 mm (0.004 in.)**

If oil clearance exceeds specifications, replace cylinder head.

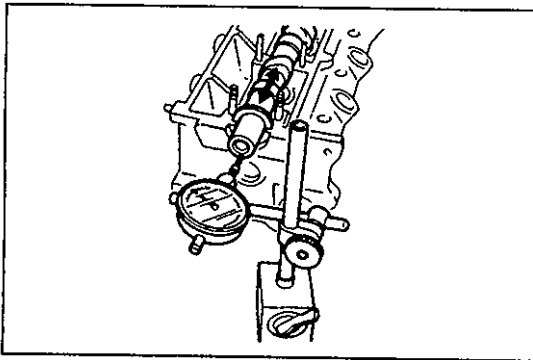

- 7) Measure camshaft end play.

**End play:**

**Standard: 0.02 – 0.15 mm (0.0008 – 0.0059 in.)**

**Maximum: 0.20 mm (0.008 in.)**

If it exceeds specifications, replace camshaft and/or cylinder head.

**INSTALLATION****Valve Seal**

- 1) Assemble special tool so that depth "a" is as specified.

**Depth "a": 10.2 – 10.8 mm (0.402 – 0.425 in.)**

- 2) Apply engine oil to inside of new valve seal.
- 3) Press valve seal on until the special tool contacts the cylinder head.

**Special Tool**

**(A): 09916-57810**

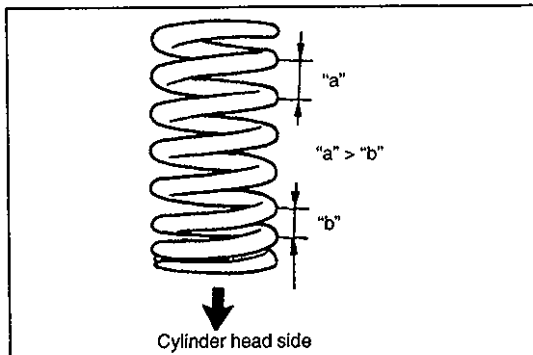
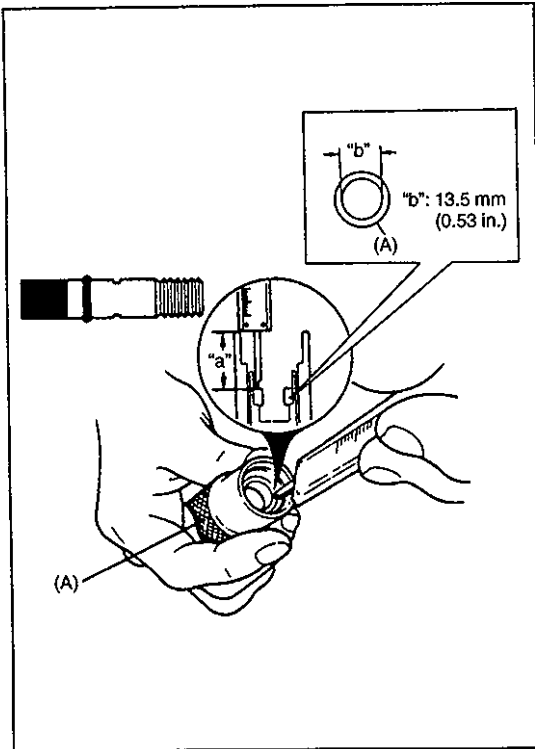
**Valve and Valve Spring**

- 1) Install lower spring seat.
- 2) Install valve.

**CAUTION:**

**Install spring with the closer pitch toward cylinder head.**

- 3) Install valve spring and upper spring seat.

- 4) Compress valve spring by using special tool, and install valve keepers.

**Special Tool**

**(A): 09916-14510**

**(B): 09916-48210**

- 5) Remove special tool.

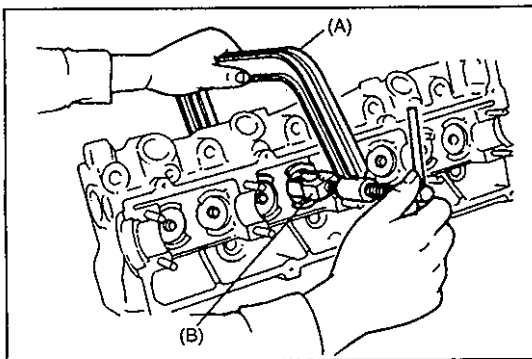

- 6) Tap end of valve stem lightly two or three times with a plastic hammer to verify that keepers are all fully seated.

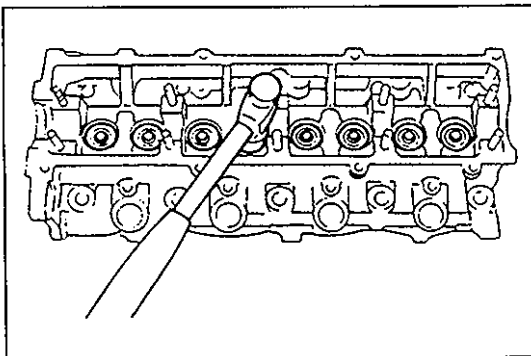

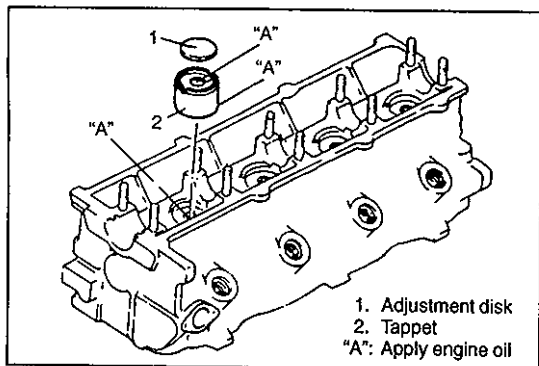

### Tappet and Adjustment Disk

- 1) Apply engine oil to tappets as shown in the figure.
- 2) Install tappets in hole.
- 3) Install adjustment disks.

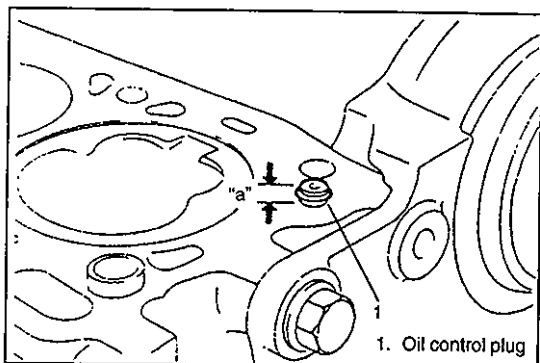

### Cylinder Head Gasket

- 1) Remove all foreign material from top of cylinder block.
- 2) Measure oil control plug height.

**Height "a": 4.9 – 5.3 mm (0.193 – 0.208 in.)**

- 3) If not correct, replace the cylinder head.
- 4) Install new O-ring to oil control plug.

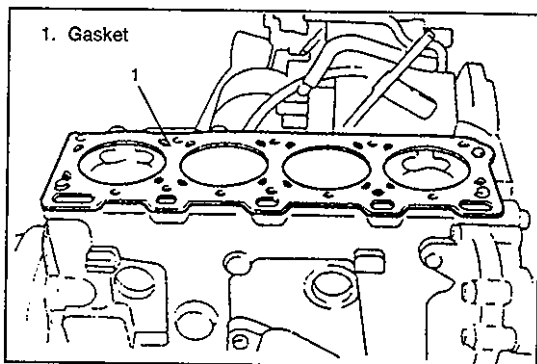

- 5) Install new cylinder head gasket.

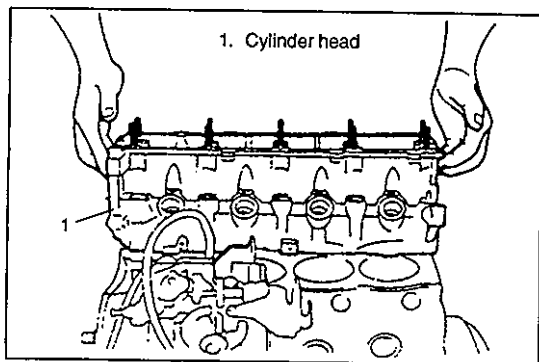

### Cylinder Head Assembly

- 1) Install cylinder head.

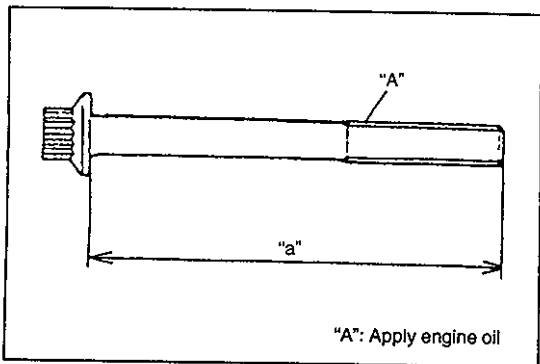

- 2) Measure length of each bolt. Replace if necessary.

**Length "a":**

**Standard: 113.2 – 113.8 mm (4.457 – 4.480 in.)**

**Maximum: 114.5 mm (4.508 in.)**

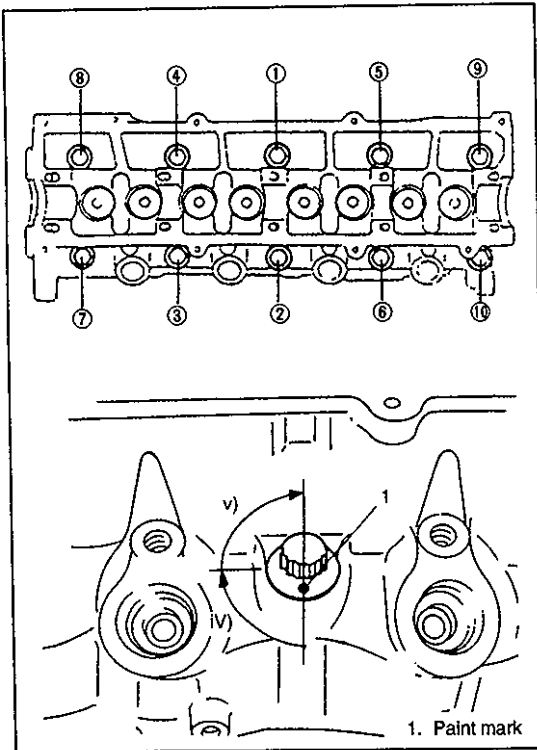

## 3) Tighten cylinder head bolts.

- i) Apply clean engine oil to bolt threads and seat faces.
- ii) Tighten cylinder head bolts in two or three steps in order shown.

**Tightening Torque for Cylinder Head Bolt**  
**30 N·m (3.0 kg-m, 21.5 lb-ft)**

- iii) Make paint marks on bolt heads, as shown in figure.

- iv) With paint marks as a reference point, tighten cylinder head bolts another  $90^\circ \sim 105^\circ$  in tightening order.
- v) Then tighten them once again  $90^\circ \sim 105^\circ$  in tightening order.

**CAUTION:**

**Be sure to tighten bolts in the specified order.**

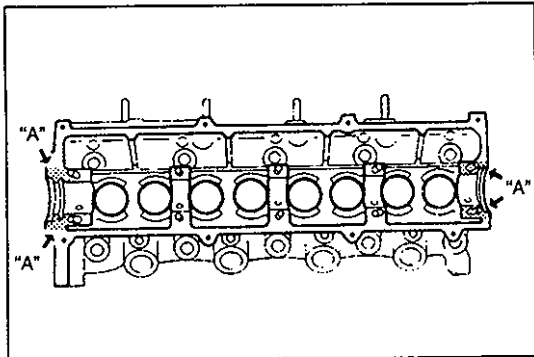
**Camshaft**

- 1) Apply clean engine oil to camshaft journals and bearings.

**CAUTION:**

**Do not allow any sealant on camshaft journal surfaces.**

- 2) Apply sealant to shaded areas "A" as shown in figure.

**"A": SUZUKI BOND No. 1215, 99000-31110**

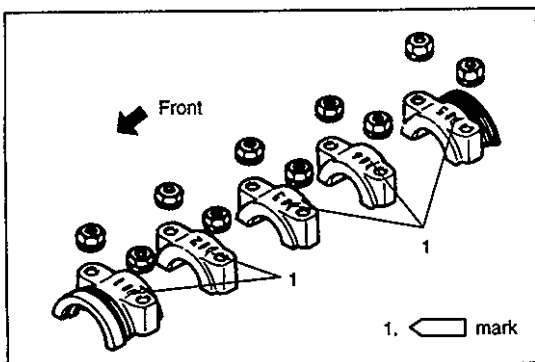

- 3) Install camshaft caps according to the cap number and  mark as shown in the figure.

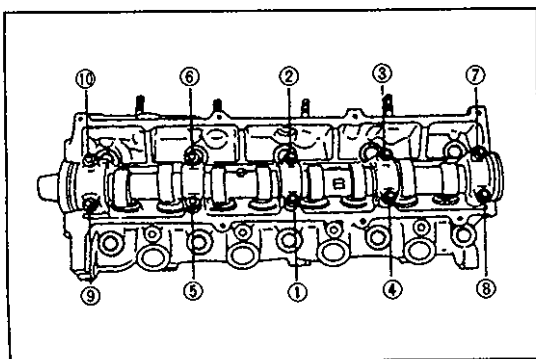

- 4) Install camshaft cap nuts and tighten them in two or three steps in order shown in figure.

**Tightening Torque for Camshaft Cap Nut**  
**24 N·m (2.4 kg-m, 17.5 lb-ft)**

**NOTE:**

**Adjustment of the valve clearance should be made only after camshaft pulley, injection pump pulley and timing belt have been installed.**

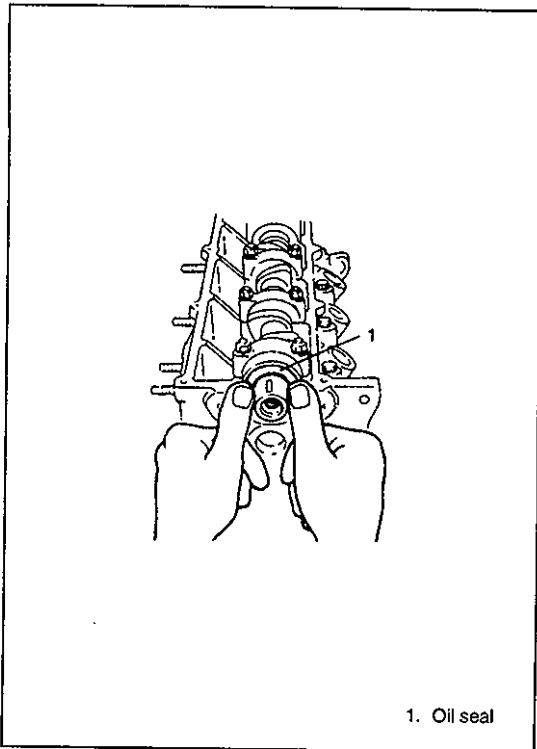

- 5) Apply clean engine oil to lip of each new camshaft oil seal.
- 6) Push oil seals slightly in by hand.

**CAUTION:**

**Oil seal must be tapped in until it is flush with the edge of camshaft cap.**

- 7) Tap oil seals in evenly by using a suitable pipe and a hammer.

**Oil seal outer diameter: 46 mm (1.81 in.)**

**Oil seal inner diameter: 32 mm (1.26 in.)**

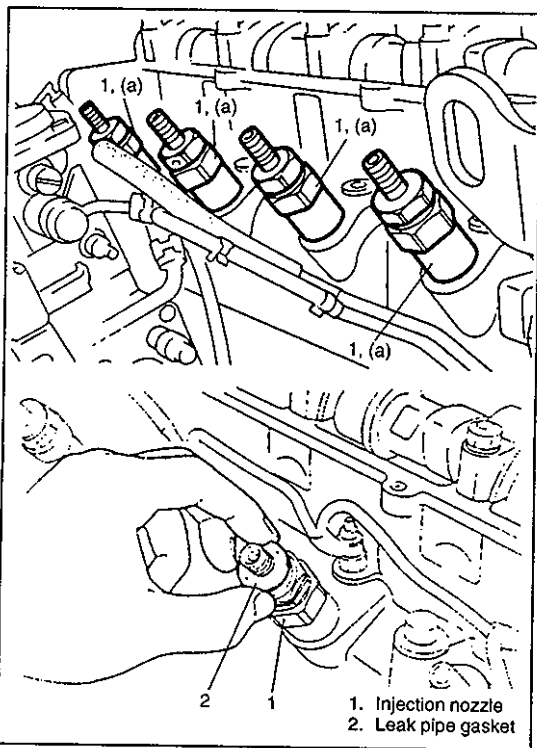

**Injection Nozzle and Leak Pipe**

- 1) Install new corrugated washers and new copper gaskets in position.
- 2) Install injection nozzles.

**Tightening Torque**

**(a): 65 N·m (6.5 kg-m, 47 lb-ft)**

**NOTE:**

**Corrugated washers and copper gaskets must be replaced with new ones each time injection nozzles are removed.**

- 3) Install new leak pipe gasket.

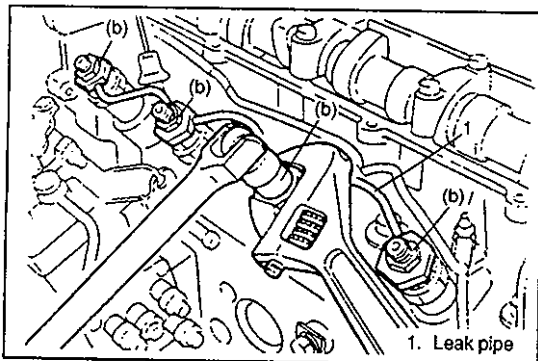

- 4) Install leak pipe.
- 5) Tighten leak pipe nut to specified torque.

**Tightening Torque**

**(b): 38 N·m (3.8 kg-m, 27.5 lb-ft)**

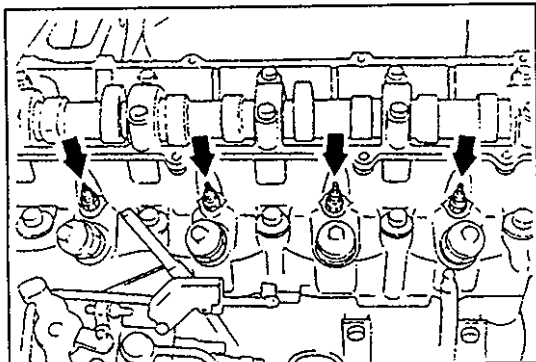

### Glow Plug and Glow Cord

- 1) Install glow plugs.

**Tightening Torque for Glow Plug**  
18 N·m (1.8 kg-m, 13 lb-ft)

- 2) Install glow cord nut.

**Tightening Torque for Glow Cord Nut**  
10 N·m (1.0 kg-m, 7 lb-ft)

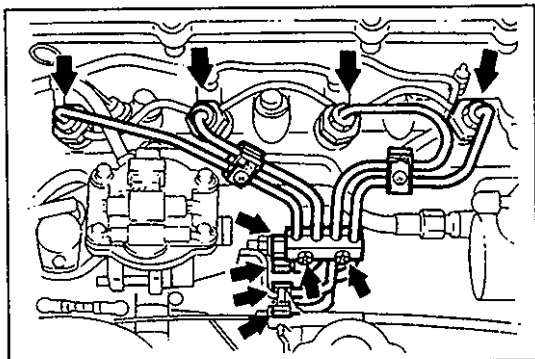

### Injection pipe

- 1) Install injection pipes and loosely tighten nuts.

- 2) Tighten injection pipe nuts by using special tool.

### Tightening Torque

(a): 28 N·m (2.8 kg-m, 20 lb-ft)

### Special Tool

(A): 09950-76010

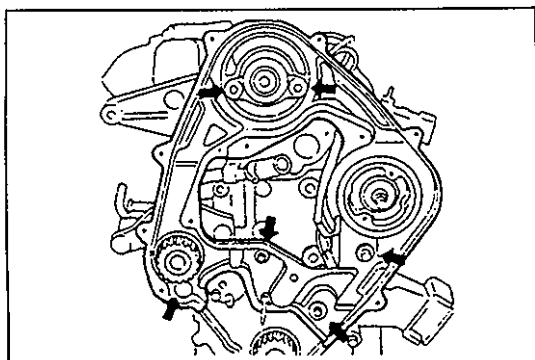
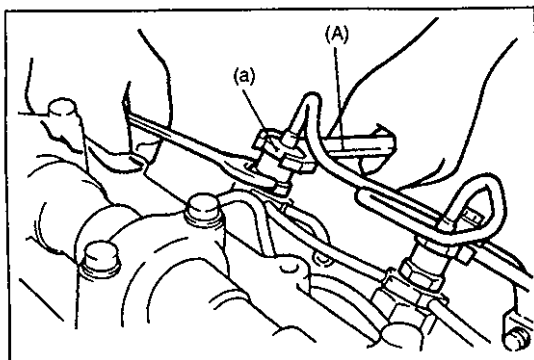

### Seal Plate

Install seal plate.

**Tightening Torque for Seal Plate Bolt**  
10 N·m (1.0 kg-m, 7 lb-ft)

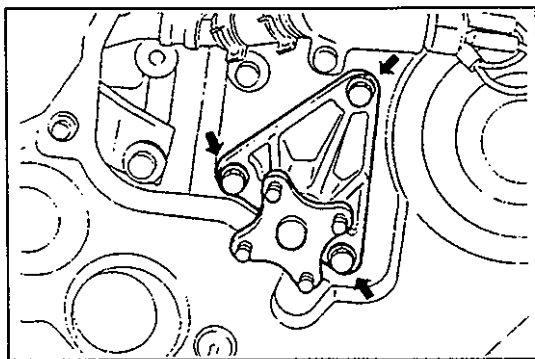

### Cooling Fan Bracket

Install fan bracket.

**Tightening Torque for Cooling Fan Bracket Bolt**  
40 N·m (4.0 kg-m, 29 lb-ft)

**Injection Pump Pulley**

Refer to "Injection Pump Pulley" of "Installation" under "Timing Belt, Pulley and Belt Tensioner" earlier in this section.

**Camshaft Pulley**

Refer to "Camshaft Pulley" of "Installation" under "Timing Belt, Pulley and Belt Tensioner" earlier in this section.

**Cylinder head cover**

Refer to "Cylinder Head Cover" of "Installation" under "Timing Belt, Pulley and Belt Tensioner" earlier in this section.

## OIL FILTER, OIL PRESSURE SWITCH, OIL COOLER AND ENGINE HANGER

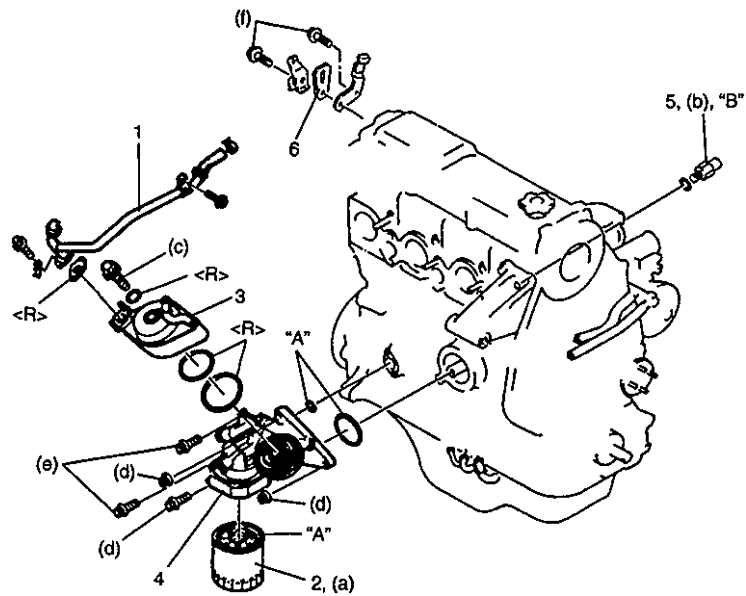

1. Pipe
2. Oil filter cartridge
3. Oil cooler
4. Oil filter body
5. Oil pressure switch
6. Engine hanger

## Tightening Torque

- (a): 23 N·m (2.3 kg-m, 17 lb-ft)  
 (b): 15 N·m (1.5 kg-m, 11 lb-ft)  
 (c): 30 N·m (3.0 kg-m, 22 lb-ft)  
 (d): 40 N·m (4.0 kg-m, 29 lb-ft)  
 (e): 9 N·m (0.9 kg-m, 6.5 lb-ft)  
 (f) : 20 N·m (2.0 kg-m, 14.5 lb-ft)

"A" : Apply engine oil.

"B" : Apply sealant SUZUKI BOND No. 1207C, 99000-31150.

<R>: Replace.

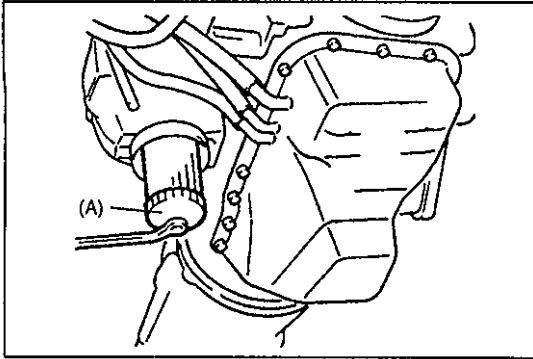
**REMOVAL**

Remove in order shown in the figure on the previous page, and note following points.

**Oil Filters**

Remove oil filter with a special tool.

**Special Tool**

(A): 09915-47810

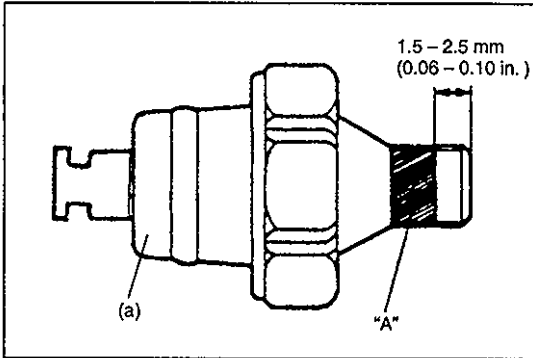
**INSTALLATION**

For installation, reverse removal procedure and note following points.

**Oil Pressure Switch**

1) Apply sealant to thread of oil pressure switch as shown.

“A”: SUZUKI BOND No. 1207C, 99000-31150

2) Install oil pressure switch.

**Tightening Torque**

(a): 15 N·m (1.5 kg-m, 11 lb-ft)

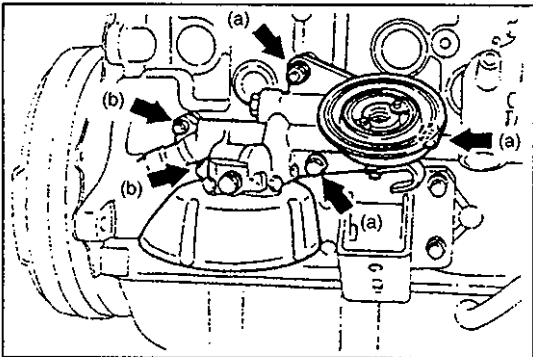
**Oil Filter Cartridge and Filter Body**

1) Install oil filter body.

**Tightening Torque**

(a): 40 N·m (4.0 kg-m, 29 lb-ft)

(b): 9 N·m (0.9 kg-m, 6.5 lb-ft)

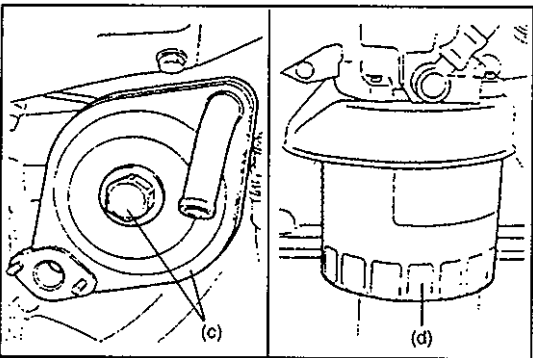

2) Install oil cooler.

**Tightening Torque**

(c): 30 N·m (3.0 kg-m, 22 lb-ft)

3) Apply a coat of engine oil to the filter rubber seal.

4) Install oil filter until rubber seal contacts oil cooler by hand. Then tighten it a 1-1/6 turn further with a special tool.

**Tightening Torque**

(d): 23 N·m (2.3 kg-m, 17 lb-ft)

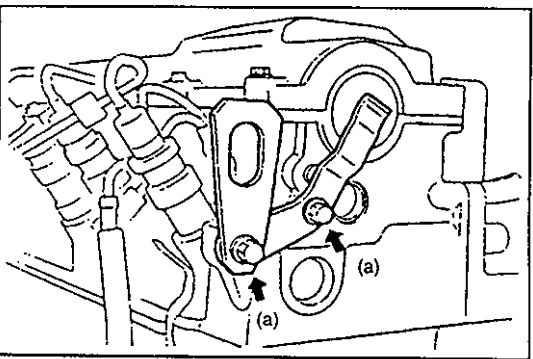
**Engine Hanger**

Install engine hanger.

**Tightening Torque**

(a): 20 N·m (2.0 kg-m, 14.5 lb-ft)

## OIL PAN, OIL PUMP AND DRIVE PLATE

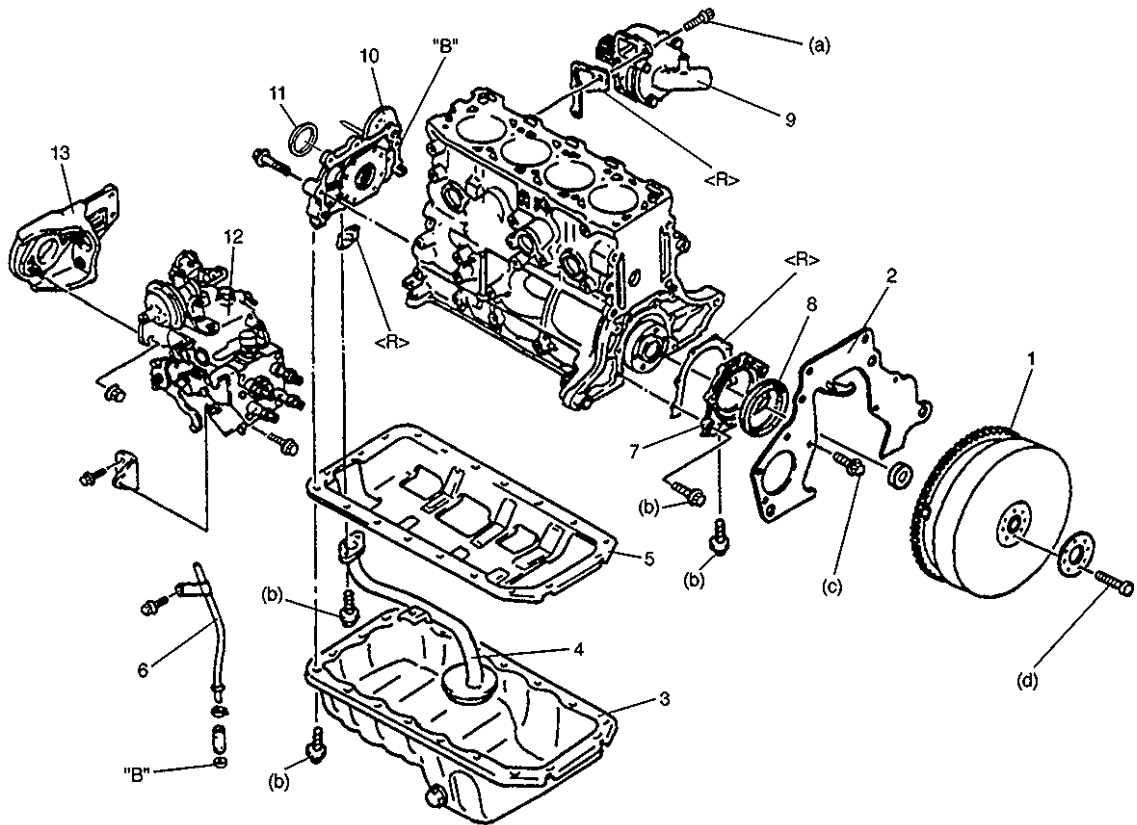

- |  |   |
|--|---|
| <ol style="list-style-type: none"> <li>1. Drive plate</li> <li>2. End plate</li> <li>3. Oil pan</li> <li>4. Oil strainer</li> <li>5. Oil baffle plate</li> <li>6. Oil level gauge pipe</li> <li>7. Rear cover</li> <li>8. Rear oil seal</li> </ol> | <ol style="list-style-type: none"> <li>9. Water pump (For removal and installation refer to SECTION 6B.)</li> <li>10. Oil pump assembly</li> <li>11. Front oil seal</li> <li>12. Fuel injection pump (For removal and installation refer to SECTION 6E3.)</li> <li>13. Fuel injection pump bracket</li> </ol> |
|--|---|

**Tightening Torque**

- (a): 40 N·m (4.0 kg·m, 29 lb-ft)  
 (b): 10 N·m (1.0 kg·m, 7 lb-ft)  
 (c): 23 N·m (2.3 kg·m, 16.5 lb-ft)  
 (d): 100 N·m (10.0 kg·m, 72.5 lb-ft)

"B": Apply sealant SUZUKI BOND No. 1207C, 99000-31150.  
 <R>: Replace.

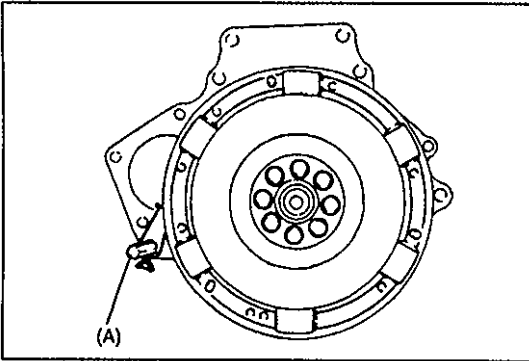

## REMOVAL

### Drive Plate

- 1) Hold drive plate by using the special tool.

#### Special Tool

(A): 09924-17810

- 2) Remove drive plate bolts.
- 3) Remove drive plate.

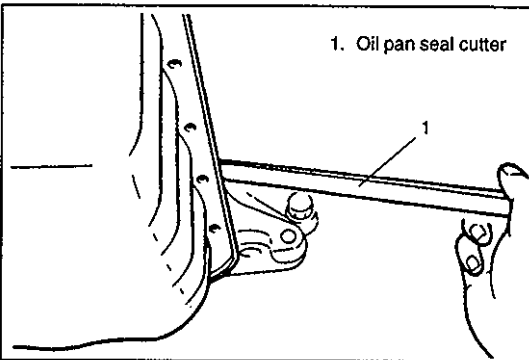

### Oil Pan

- 1) Remove oil pan mounting bolts.
- 2) Insert oil pan seal cutter between oil pan and oil baffle plate to separate them.

#### CAUTION:

Do not bend oil pan when prying it.

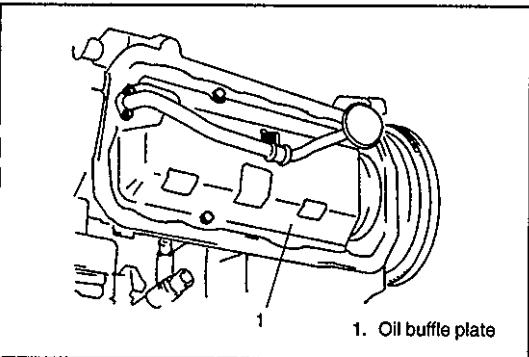

### Oil Baffle Plate

- 1) Remove oil baffle plate mounting bolts.
- 2) Insert oil pan seal cutter between oil baffle plate and cylinder block to separate them.

#### CAUTION:

Do not bend oil baffle plate when prying it.

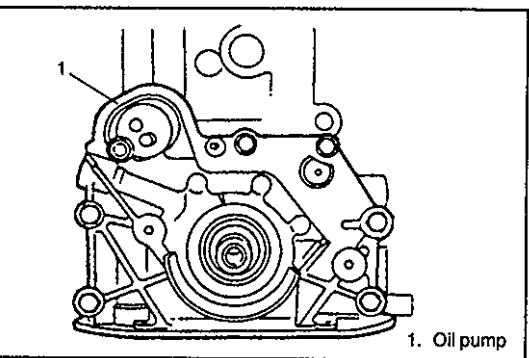

### Oil Pump

- 1) Remove oil pump mounting bolts.
- 2) Insert oil pan seal cutter between oil pump and cylinder block to separate them.

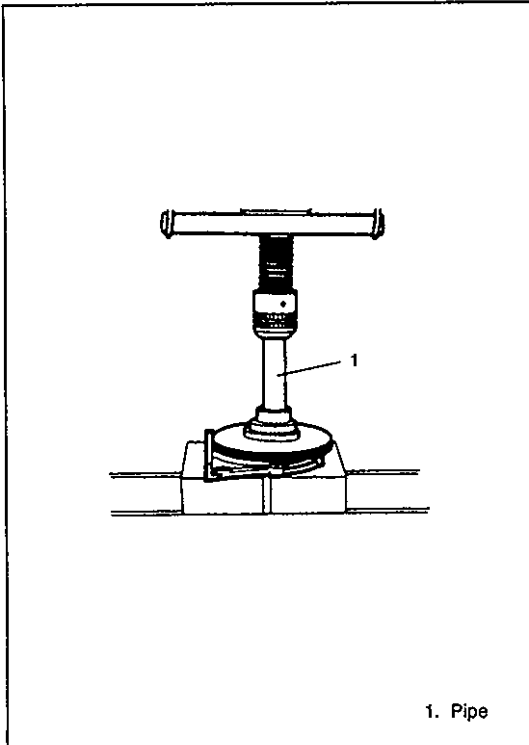

## INSTALLATION

### Rear Cover

- 1) Apply clean engine oil to the lip of new oil seal.
- 2) Push oil seal slightly in by hand.

#### CAUTION:

Oil seal must be pressed in until it is flush with edge of the rear cover.

- 3) Press oil seal in evenly by using suitable pipe.

Oil seal outer diameter: 100 mm (3.9 in.)

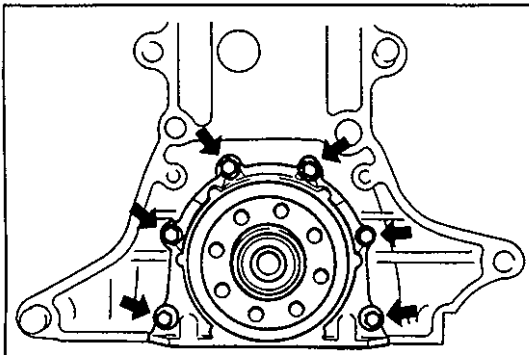

- 4) Install rear cover and new gasket.
- 5) Tighten rear cover mounting bolt to specified torque.

**Tightening Torque for Rear Cover Mounting Bolt:**  
10 N·m (1.0 kg·m, 7.5 lb-ft)

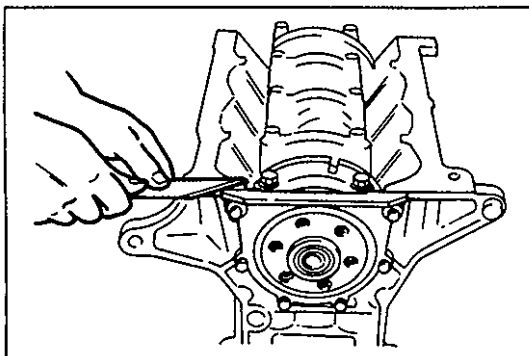

- 6) Cut away portion of gasket that projects out from rear cover assembly toward oil pan side.

#### CAUTION:

Do not scratch rear cover assembly.

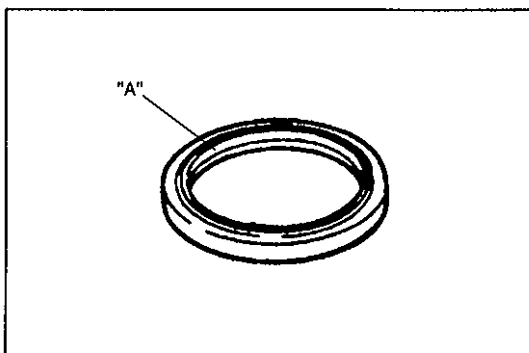

### Oil Pump

- 1) Apply clean engine oil to lip "A" of new oil seal.
- 2) Push seal slightly in by hand.

#### CAUTION:

Oil seal must be pressed in until it is flush with edge of oil pump body.

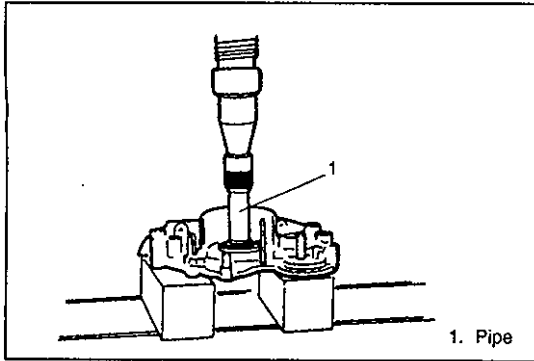

3) Press oil seal in evenly by using suitable pipe.

Oil seal outer diameter: 48 mm (1.89 in.)

Oil seal inner diameter: 33.7 mm (1.33 in.)

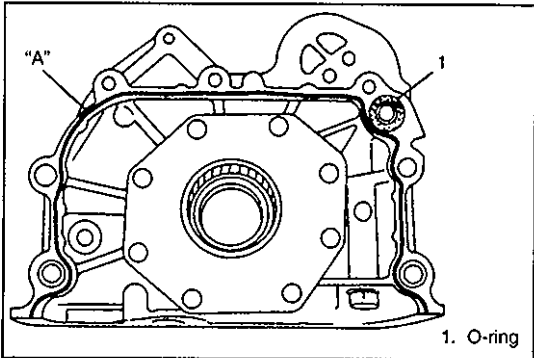

4) Apply continuous bead of silicone sealant to oil pump housing as shown in figure.

“A”: SUZUKI BOND No. 1207C, 99000-31150

**CAUTION:**

Do not allow any sealant to get into oil hole.

5) Install new O-ring into pump body.

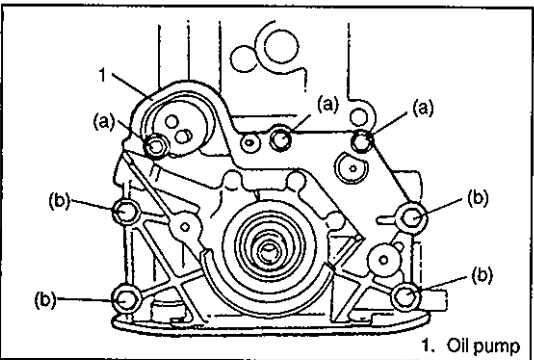

6) Install oil pump and generator bracket.

**Tightening Torque**

(a): 20 N·m (2.0 kg-m, 14.5 lb-ft)

(b): 40 N·m (4.0 kg-m, 29 lb-ft)

**CAUTION:**

Do not scratch the oil pump.

7) Remove any sealant that is pushed out at oil pan side.

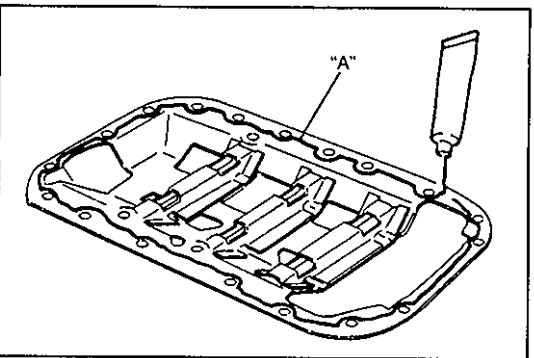

**Oil Baffle Plate**

1) Remove all foreign material from contact surfaces.

2) Apply a continuous bead of silicone sealant to oil baffle plate along inside of bolt holes, and overlap ends.

3) Install oil baffle plate and then tighten mounting torque to specified torque.

**Tightening Torque:**

10 N·m (1.0 kg-m, 7 lb-ft)

“A”: SUZUKI BOND No. 1207C, 99000-31150

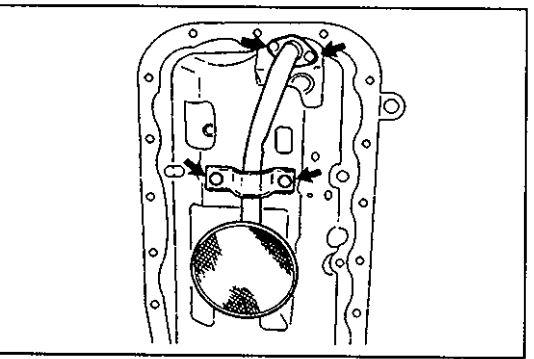

**Oil Strainer**

1) Install oil strainer along with new gasket.

2) Tighten mounting bolt to specified torque.

**Tightening Torque for Oil Strainer Bolt:**

10 N·m (1.0 kg-m, 7 lb-ft)

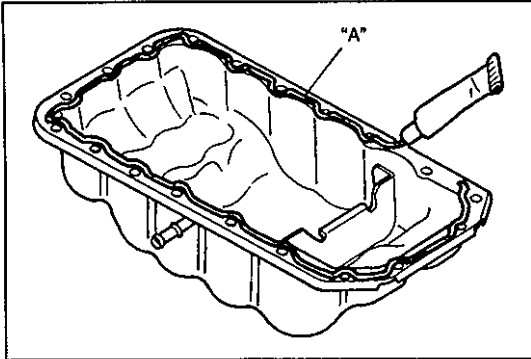

### Oil Pan

- 1) Remove all foreign material from the contact surfaces.
- 2) Apply continuous bead of silicone sealant to the oil pan along the inside of the bolt holes, and overlap the ends.
- 3) Install the oil pan and then tighten mounting bolt to specified torque.

#### Tightening Torque for Oil Pan Bolt

10 N·m (1.0 kg-m, 7 lb-ft)

"A": SUZUKI BOND No. 1207C, 99000-31150

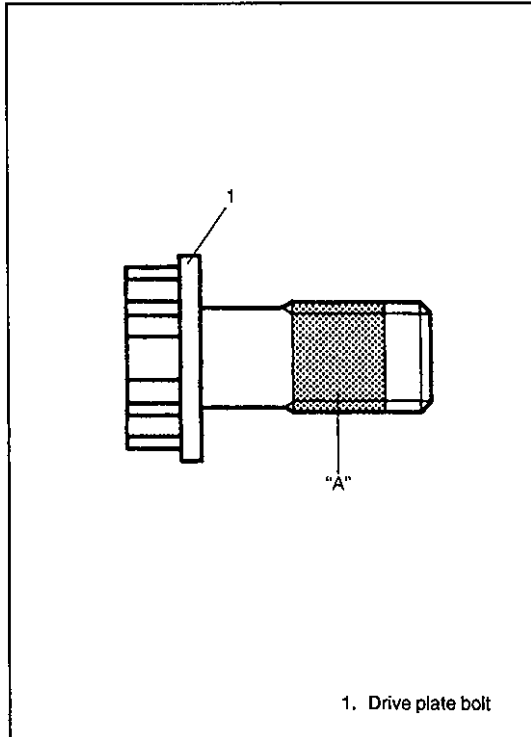

### Drive Plate

- 1) Remove sealant from the drive plate bolt holes in crankshaft and from drive plate bolts.

#### CAUTION:

- If all previous thread lock cannot be removed from a bolt, replace bolt.
- Do not apply thread lock if new bolt is used.

- 2) Set drive plate onto crankshaft.
- 3) Apply thread lock to drive plate bolts and install them.

"A": SUZUKI BOND No. 1332, 99000-32020

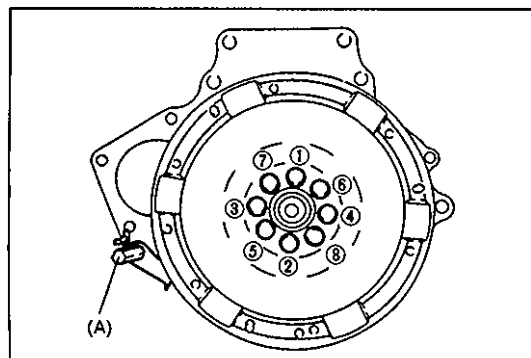

- 4) Hold flywheel by using special tool.

#### Special Tool

(A): 09924-17810

- 5) Tighten bolts in two or three steps in order shown in figure.

#### Tightening Torque for Drive Plate Bolt

100 N·m (10.0 kg-m, 72.5 lb-ft)

# OIL PUMP

## DISASSEMBLY/ASSEMBLY

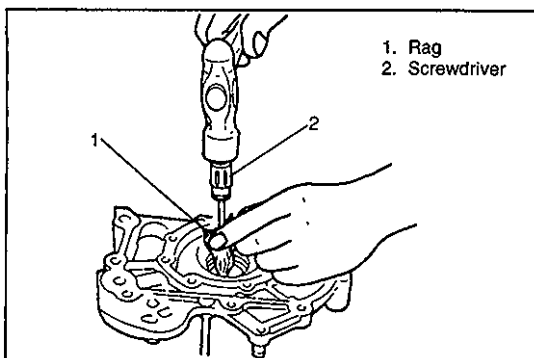
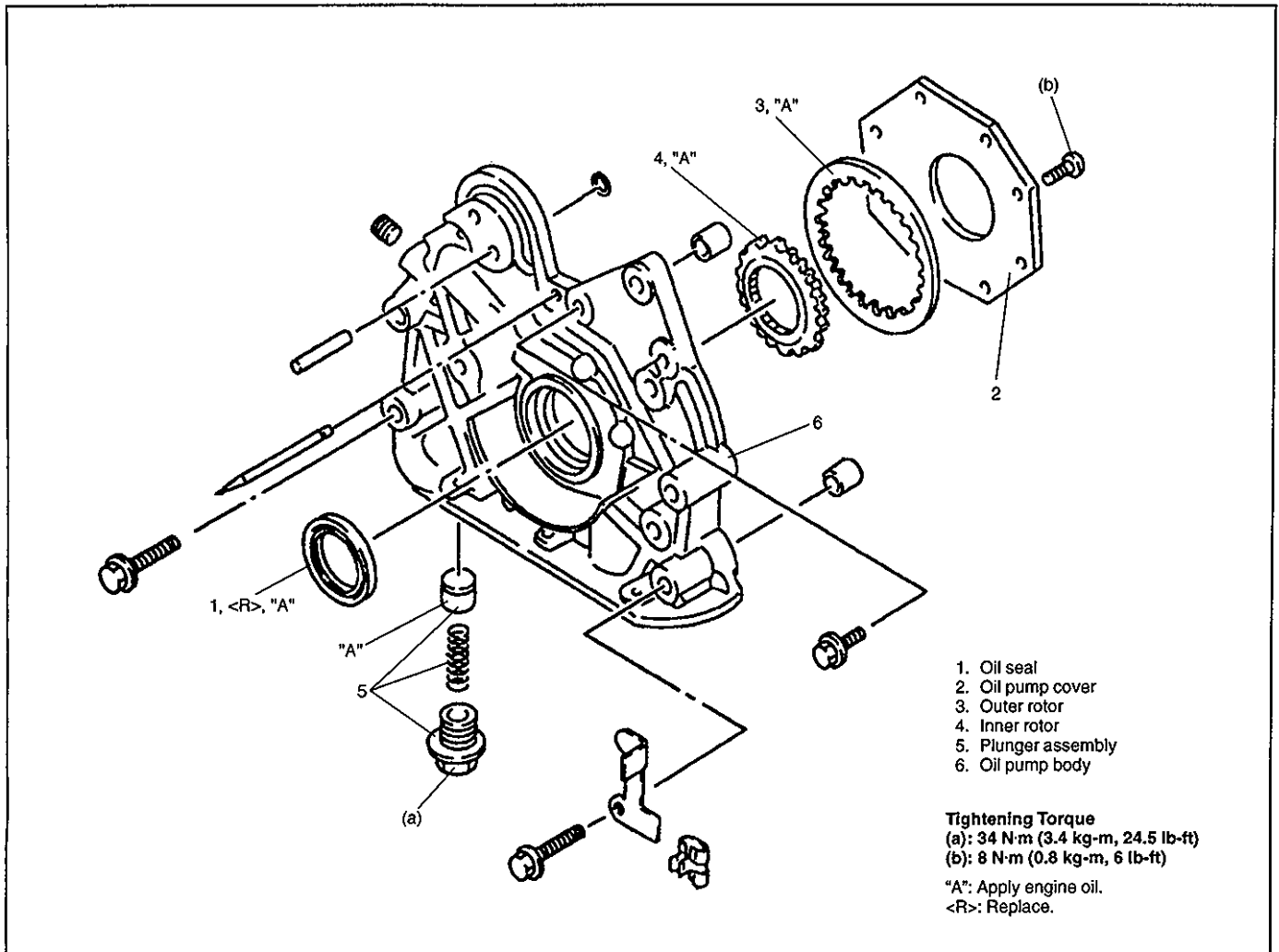

### DISASSEMBLY

Disassemble in order shown in the above figure, and note followings.

#### Oil Seal

Remove oil seal with screwdriver that is protected with rag.

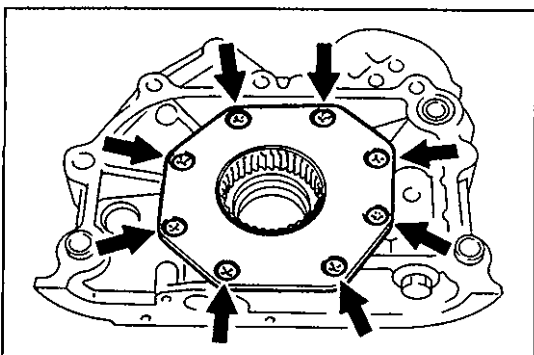

#### Pump Cover

- 1) Remove pump cover mounting bolts with screwdriver.
- 2) Remove pump cover.

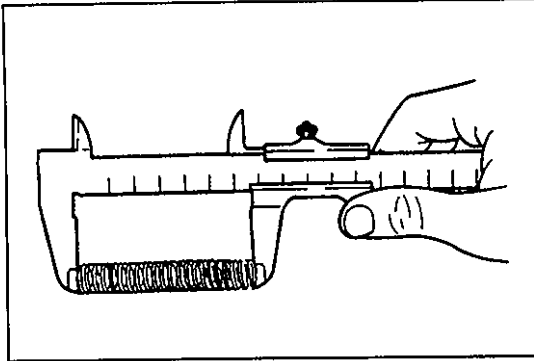

## INSPECTION

### Pressure Spring

- 1) Inspect spring for weakness or breakage.
- 2) Measure free length. Replace spring if necessary.

**Free length: 61.7 mm (2.43 in.)**

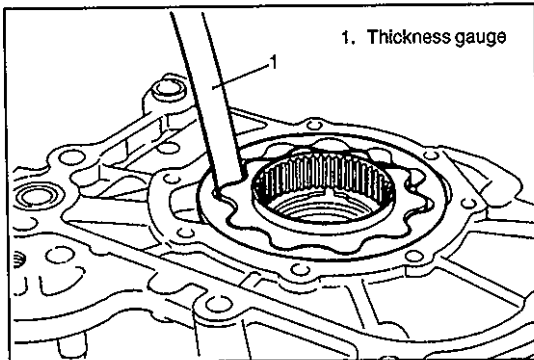

### Rotor Clearance

Measure following clearance. Replace rotor if necessary.

#### Tooth tip clearance:

**Standard: 0.2 mm (0.008 in.) or less**

**Maximum: 0.24 mm (0.009 in.)**

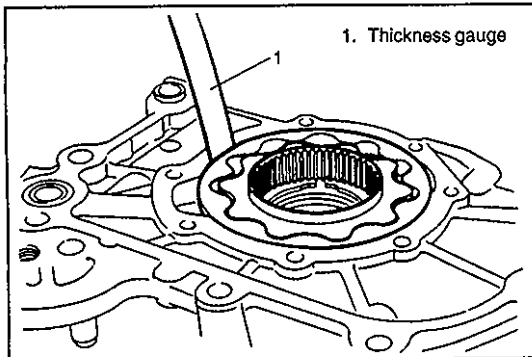

#### Outer rotor to pump body clearance:

**Standard: 0.09 – 0.184 mm (0.0036 – 0.0072 in.)**

**Maximum: 0.22 mm (0.009 in.)**

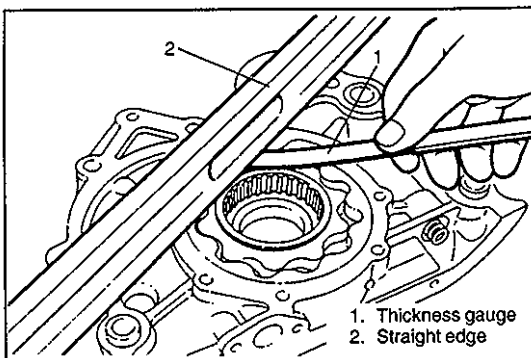

#### Side clearance:

**Standard: 0.03 – 0.09 mm (0.0012 – 0.0035 in.)**

**Maximum: 0.10 mm (0.004 in.)**

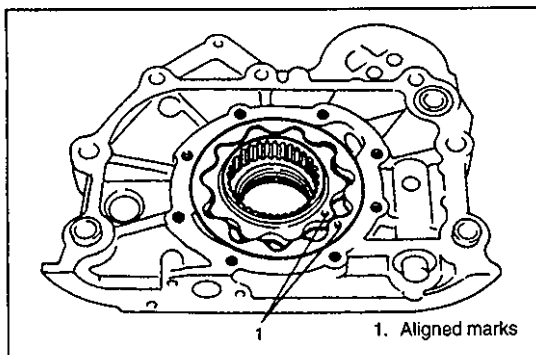

## ASSEMBLY

For assembly, reverse disassembly procedure and note followings.

### Inner and Outer Rotor

- 1) Apply small amount of clean engine oil to contact surface of pump body.
- 2) Install inner and outer rotors into oil pump body. Align marks as shown.

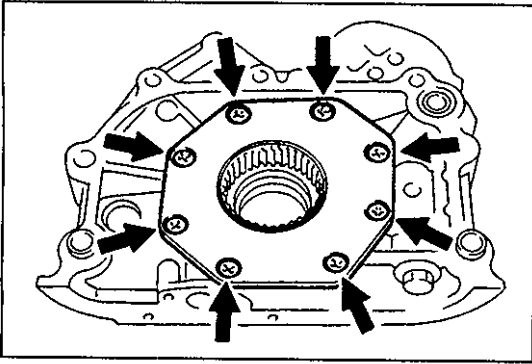

### Pump Cover

- 1) Install pump cover and then tighten screw to specified torque.

#### Tightening Torque for Pump Cover Screw:

8 N·m (0.8 kg-m, 6 lb-ft)

- 2) Make sure that inner rotor can be rotated smoothly by hand.

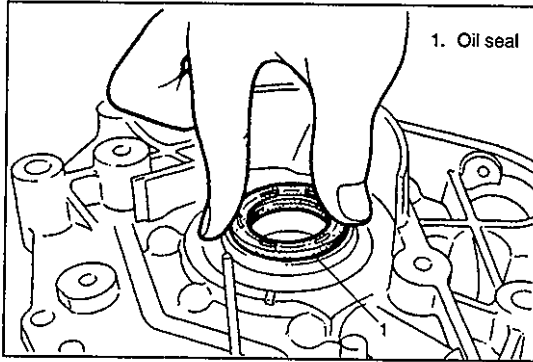

### Oil Seal

- 1) Apply a small amount of clean engine oil to lip of new oil seal.
- 2) Push in oil seal slightly by hand.

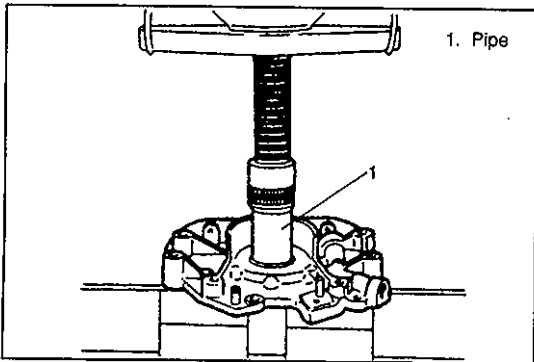

- 3) Press oil seal in evenly with suitable pipe.

#### CAUTION:

Oil seal must be pressed in until it is flush with edge of the oil pump body.

Oil seal outer diameter: 48.0 mm (1.89 in.)

Oil seal inner diameter: 33.7 mm (1.33 in.)

## ENGINE ASSEMBLY

### REMOVAL

- 1) Remove fuel filler cap to release fuel pressure in fuel feed line.
- 2) Disconnect negative cable battery.
- 3) Remove engine hood.
- 4) Remove strut tower bar.

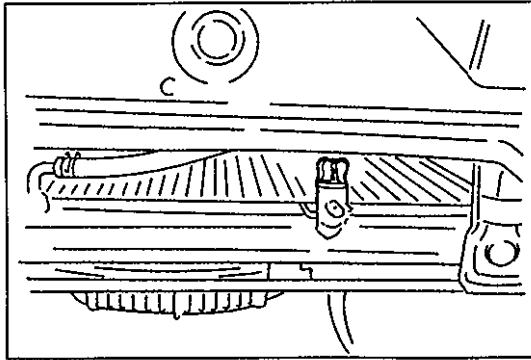
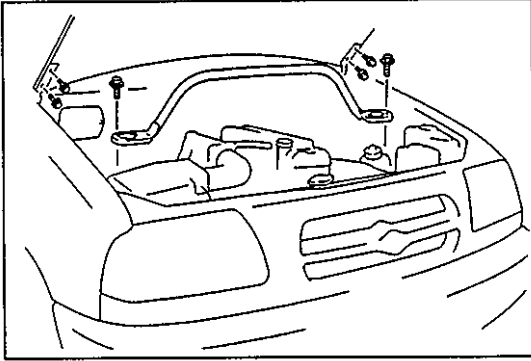

- 5) Drain coolant.
- 6) Remove radiator, radiator fan shroud and cooling fan.  
Refer to SECTION 6B for removal.

- 7) Remove air cleaner outlet hose.
- 8) Remove intercooler.
- 9) Disconnect related electric lead wires from engine (generator, starter, sensor switch, actuator, etc.).

- 10) Disconnect accelerator cable and A/T throttle cable (for A/T vehicle) from throttle body.
- 11) Disconnect following hoses:
  - Fuel feed hose and return hose
  - Heater hoses
  - Brake booster vacuum hose
  - A/T oil hose (for A/T vehicle)

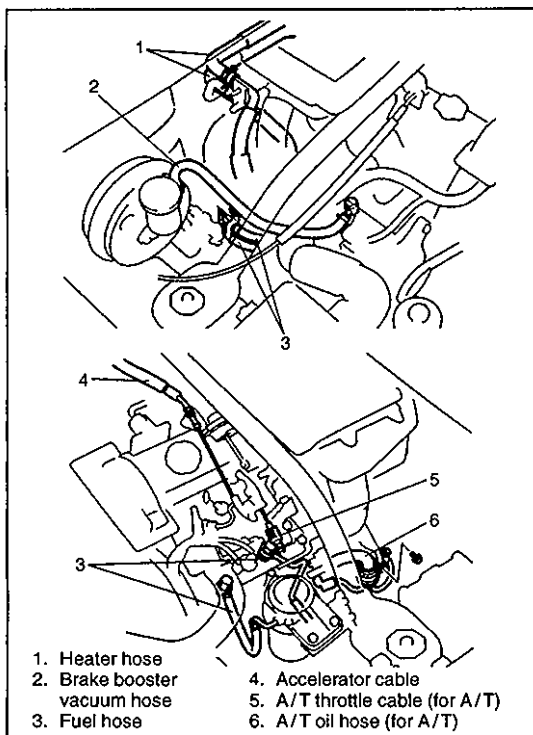

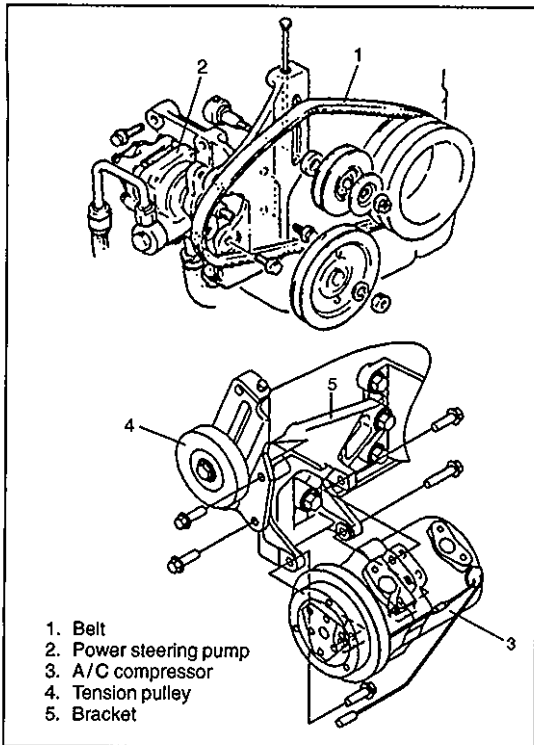

12) With hoses connected, detach power steering pump and A/C compressor from cylinder block (if equipped).

- 13) Raise vehicle.
- 14) Drain engine oil (if necessary).
- 15) Remove front differential housing with differential from chassis.  
Refer to SECTION 7E for removal.
- 16) Disconnect exhaust No.1 pipe from turbocharger.

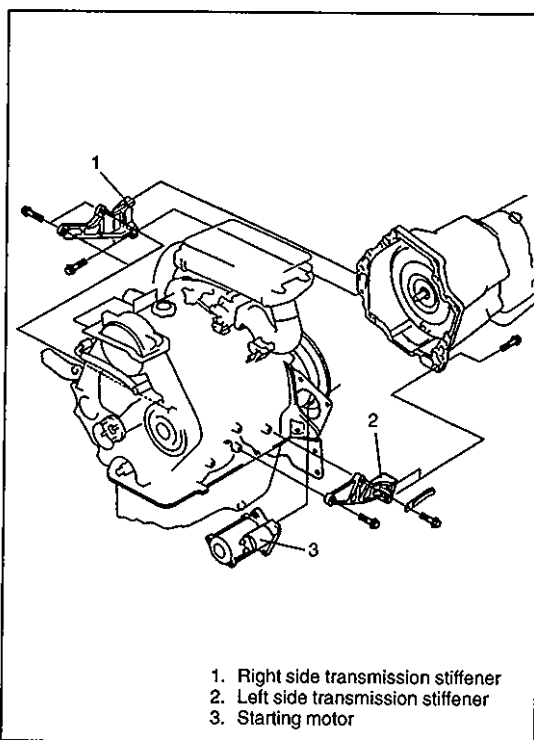

- 17) Remove starting motor.
- 18) Remove right and left side transmission stiffener.

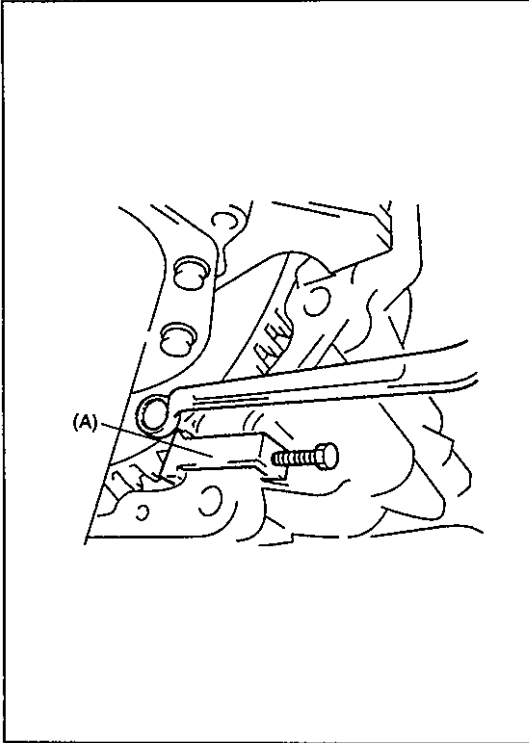

- 19) Remove clutch housing lower plate.
- 20) Remove torque converter bolts (for A/T vehicle).

**Special Tool**

**(A): 09927-56010**

- 21) Lower vehicle.
- 22) Support transmission.

**CAUTION:**

**For A/T vehicle, don't jack under A/T oil pan to support transmission.**

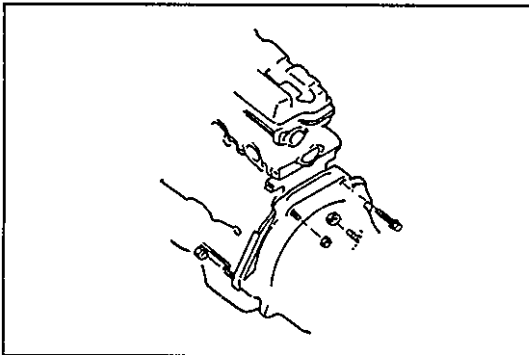

- 23) Remove bolt and nuts fastening cylinder block and transmission.

- 24) Install lifting device.
- 25) Remove engine side mounting bracket nuts from engine mountings.
- 26) Before lifting engine, check to ensure all hoses, wires and cables are disconnected from engine.
- 27) Remove engine assembly from chassis and transmission by lifting a little, sliding toward front, and then, carefully hoist engine assembly.
- 28) Remove engine mounting from engine assembly.

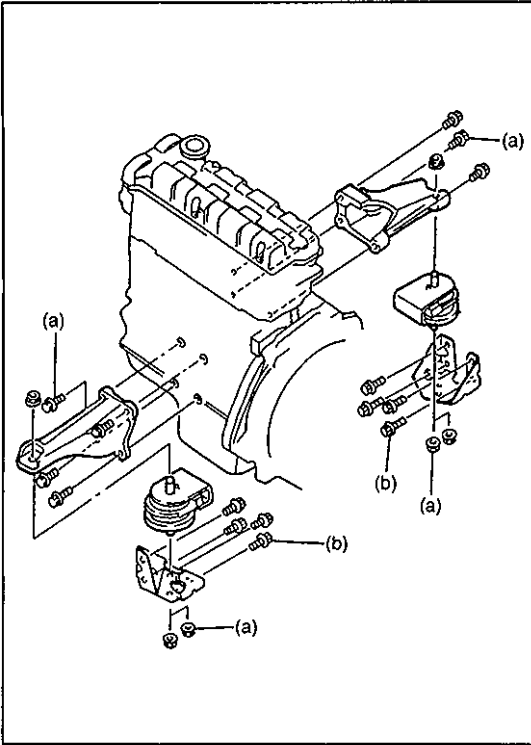

## INSTALLATION

Reverse removal procedure for installation, noting following points.

- 1) Install engine mountings to engine assembly.
- 2) Tighten bolts and nuts to specified torque.

### Tightening Torque

(a): 50 N·m (5.0 kg-m, 36 lb-ft)

(b): 85 N·m (8.5 kg-m, 61.5 lb-ft)

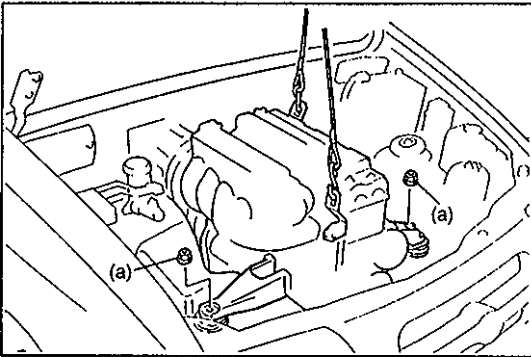

- 3) Tighten nuts fastening engine side mounting brackets and engine mountings.

### Tightening Torque

(a): 50 N·m (5.0 kg-m, 36 lb-ft)

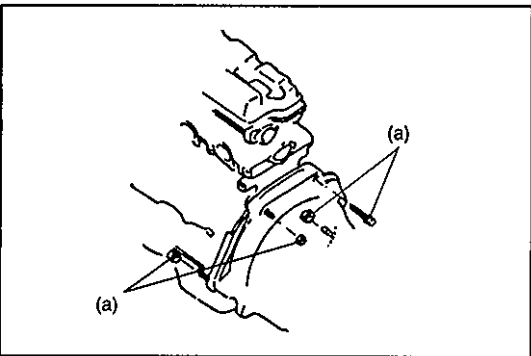

- 4) Tighten bolt and nuts fastening cylinder block and transmission to specified torque.

### Tightening Torque

(a): 85 N·m (8.5 kg-m, 61.5 lb-ft)

- 5) Remove lifting device.

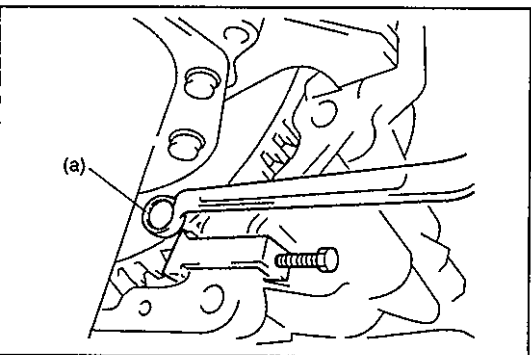

- 6) Tighten torque converter bolts to specified torque (for A/T vehicle).

### Tightening Torque

(a): 65 N·m (6.5 kg-m, 47 lb-ft)

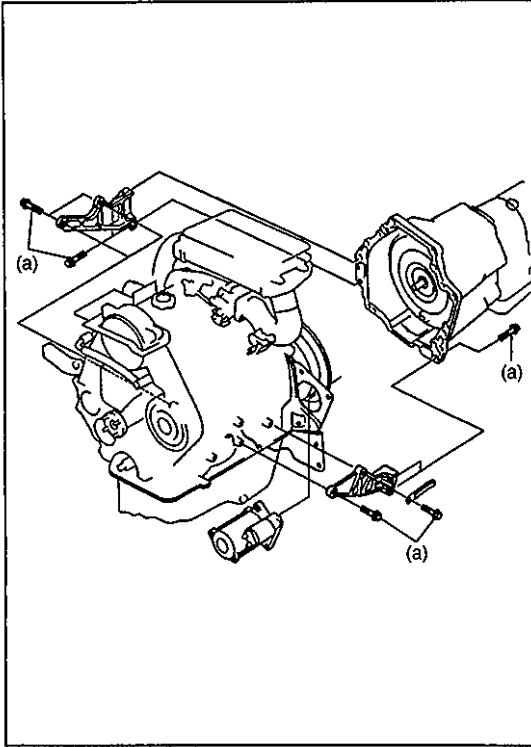

- 7) Tighten transmission stiffener bolts to specified torque if equipped.

#### Tightening Torque

(a): 50 N·m (5.0 kg·m, 36 lb·ft)

- 8) Install exhaust No.1 pipe to engine assembly and exhaust No.2 pipe, referring to SECTION 6K.
- 9) Install front differential housing with differential to chassis. Refer to SECTION 7E for installation.
- 10) Reverse disconnected hoses, cables and electric wires for connection.
- 11) Adjust power steering pump drive belt and A/C compressor drive belt tension (if equipped), referring to SECTION 0B.
- 12) Adjust accelerator cable and A/T throttle cable (for A/T vehicle) according to procedure described in SECTION 6E3.
- 13) Check to ensure that all removed parts are back in place. Reinstall any necessary parts which have not been reinstalled.
- 14) Refill engine with engine oil (if necessary), referring to item "ENGINE OIL CHANGE" in SECTION 0B.
- 15) Refill cooling system, referring to SECTION 6B.
- 16) Check to ensure that all fasteners and clamps are tightened.
- 17) Upon completion of installation, verify that there is no fuel leakage, coolant leakage or exhaust gas leakage at each connection.

## CYLINDER BLOCK, PISTON, CONNECTING ROD AND CRANKSHAFT

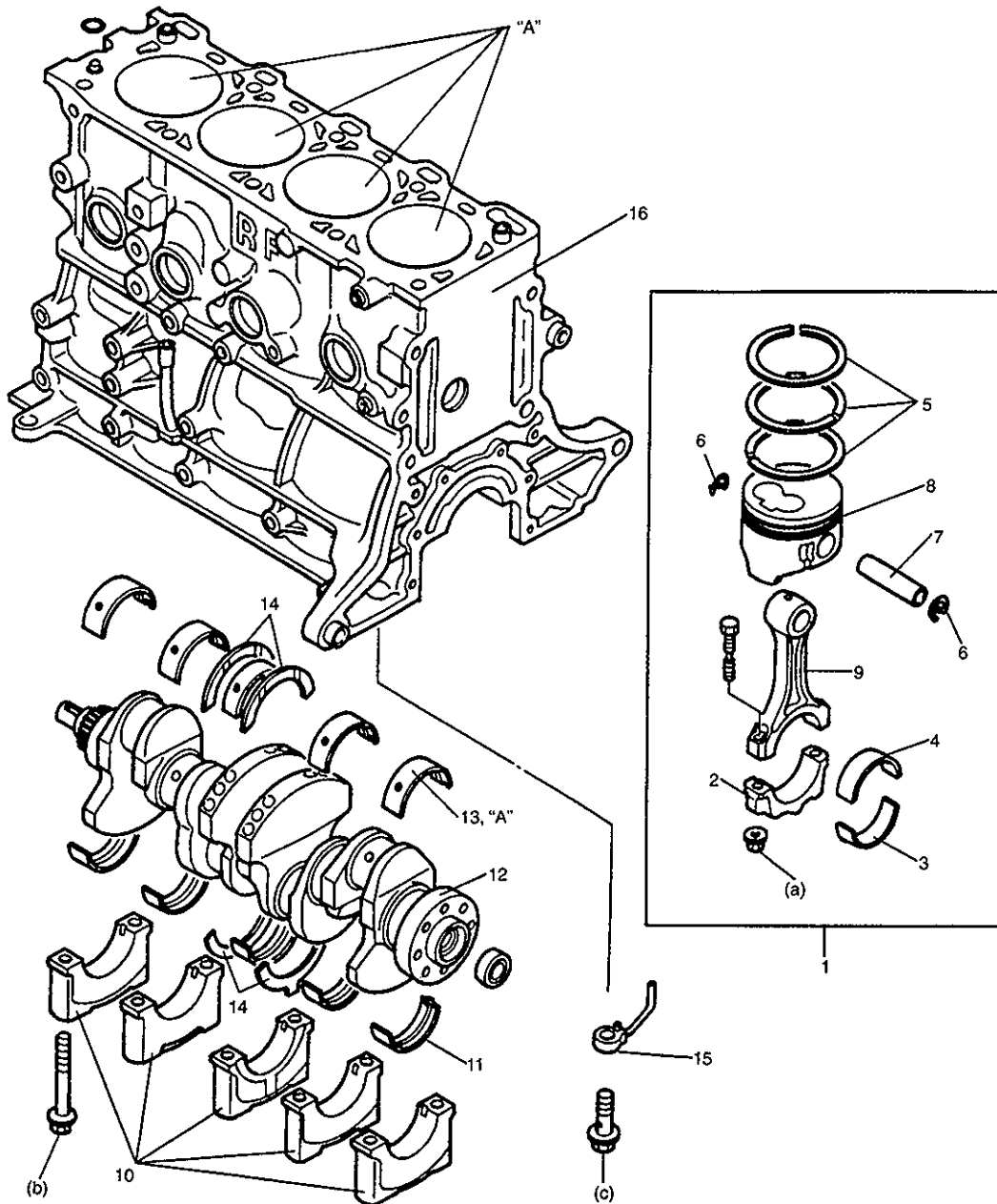

- |                                       |                               |
|---------------------------------------|-------------------------------|
| 1. Connecting rod and piston assembly | 9. Connecting rod             |
| 2. Connecting rod cap                 | 10. Main bearing cap          |
| 3. Connecting rod bearing lower       | 11. Main bearing lower        |
| 4. Connecting rod bearing upper       | 12. Crankshaft                |
| 5. Piston ring                        | 13. Main bearing upper        |
| 6. Piston pin clip                    | 14. Thrust metal              |
| 7. Piston pin                         | 15. Oil jet and oil jet valve |
| 8. Piston                             | 16. Cylinder block            |

**Tightening Torque**

(a): 65 N·m (6.5 kg-m, 47 lb-ft)

(b): 87 N·m (8.7 kg-m, 63 lb-ft)

(c): 15 N·m (1.5 kg-m, 11 lb-ft)

"A": Apply engine oil.

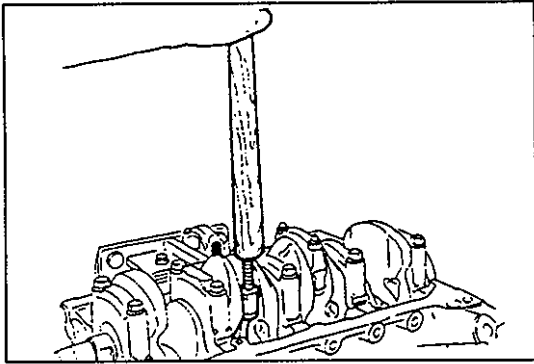

## REMOVAL

### Connecting Rod and Piston Assembly

#### CAUTION:

Do not scratch crankshaft journal or cylinder wall.

Use handle of a hammer to remove piston and connecting rod assembly through top of cylinder block.

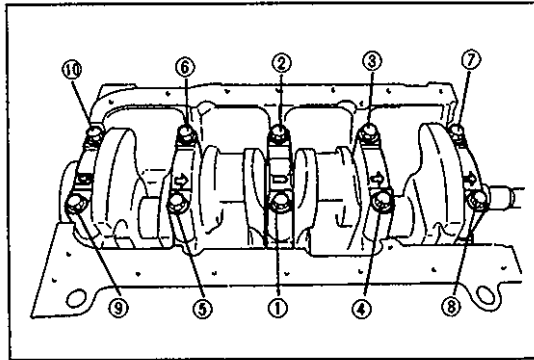

### Main Bearing Cap

- 1) Loosen main bearing cap bolts in two or three steps in order shown in figure.
- 2) Remove main bearing caps.

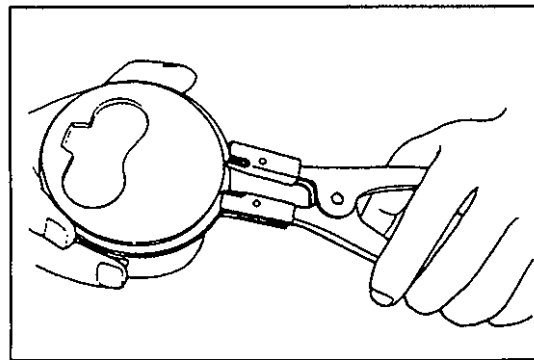

## DISASSEMBLY

### Piston Ring

#### CAUTION:

Do not apply excessive tension, which may cause rings to snap out.

Remove piston rings by using a piston ring expander.

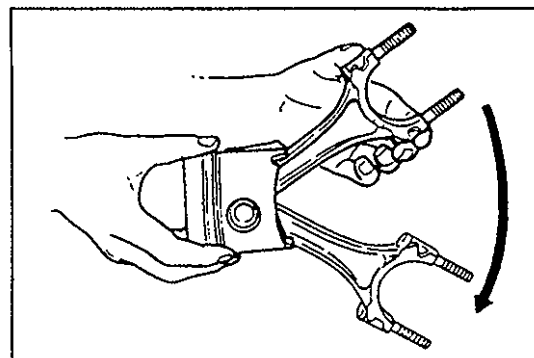

### Piston Pin

#### CAUTION:

Mark connecting rod direction for proper reassembly.

- 1) Before disassembling piston and connecting rod, check oscillation torque as shown. If large end does not drop by its own weight, replace piston and/or piston pin.

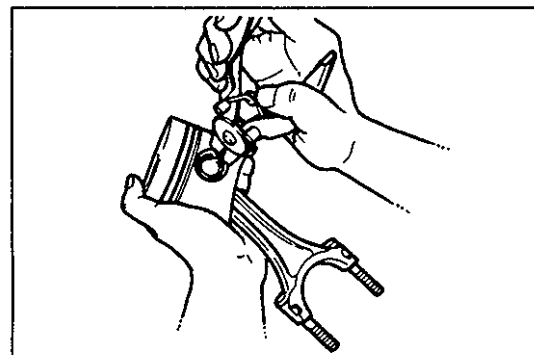

- 2) Remove snap rings from piston.

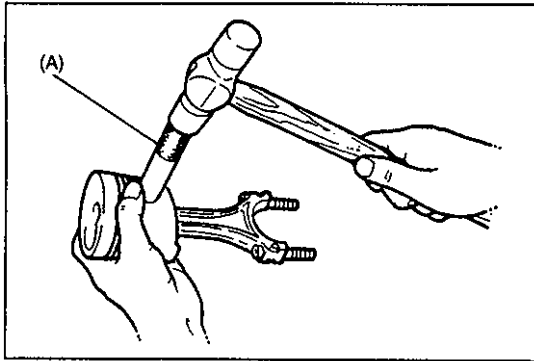

3) Remove piston pin by using special tool.

**Special Tool**  
**(A): 09910-37860**

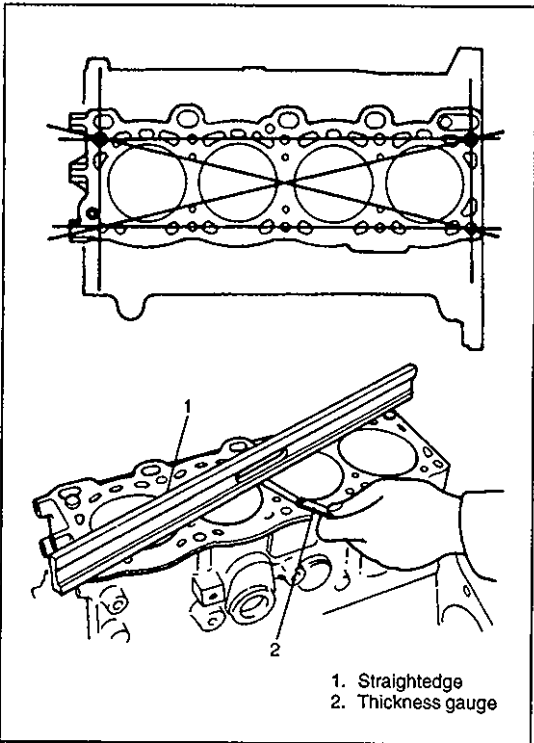

**INSPECTION**

**Cylinder Block**

- 1) Inspect cylinder block for the following. Repair or replace cylinder block as necessary.
  - Leakage damage
  - Cracks
  - Scoring of wall
- 2) Using straightedge, measure top deck of the cylinder block for distortion in the six directions shown in figure.

**Distortion: 0.10 mm (0.004 in.) max.**

If distortion exceeds specification, replace it.

**CAUTION:**  
 Do not grind surface of cylinder block.

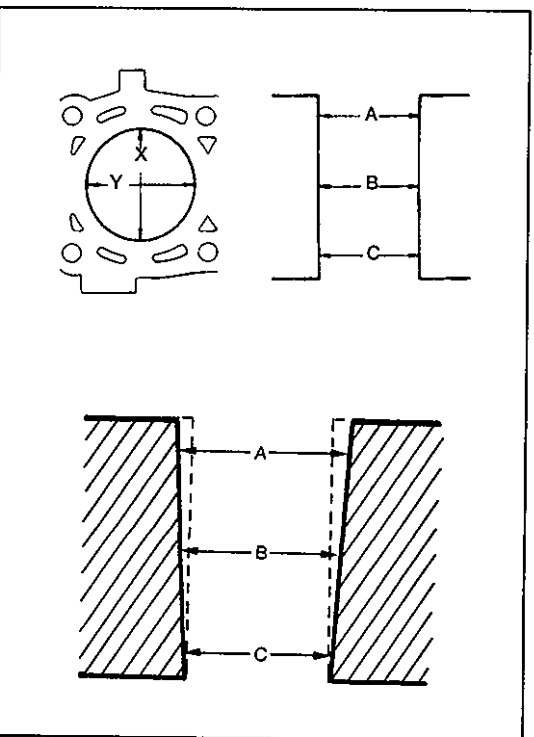

4) Measure cylinder bore in X and Y directions at three points (A, B, and C) in each cylinder as shown.

**Cylinder bore**

Size mm (in.)	Bore mm(in.)
Standard	86.000 – 86.022 (3.3859 – 3.3866)
0.25 (0.010) oversize	86.250 – 86.272 (3.3957 – 3.3965)
0.50 (0.020) oversize	86.500 – 86.522 (3.4055 – 3.4063)

**CAUTION:**  
 Boring size should be based on size of oversize piston and be same for all cylinders.

- If cylinder bore exceeds maximum, rebore it to oversize.
- If difference between measurements A and C exceeds maximum taper, rebore cylinder to oversize.

**Taper: 0.022 mm (0.0009 in.) max.**

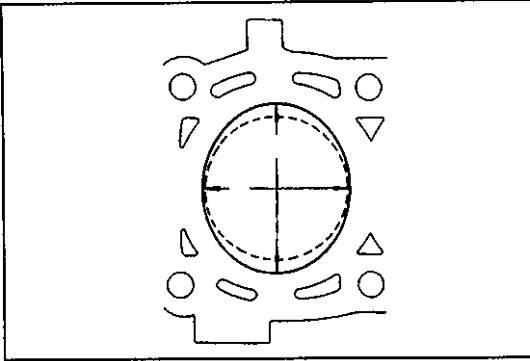

- If difference between measurements X and Y exceeds maximum out-of-round, rebore cylinder to oversize.

**Out-of-round: 0.022 mm (0.0009 in.) max.**

**CAUTION:**

**Boring size should be based on size of oversize piston and be same for all cylinders.**

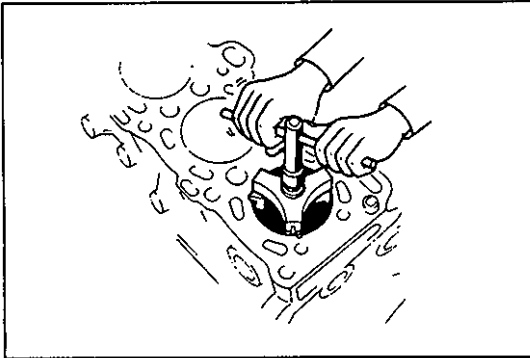

If upper part of cylinder wall shows uneven wear, remove ridge with ridge reamer.

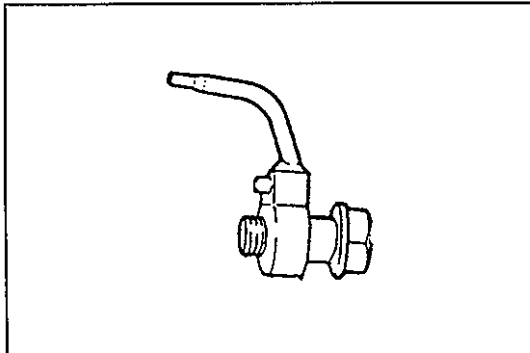

**Oil Jet**

- 1) Push check ball and verify that it moves smoothly.
- 2) Blow through oil jet and verify that air flows.

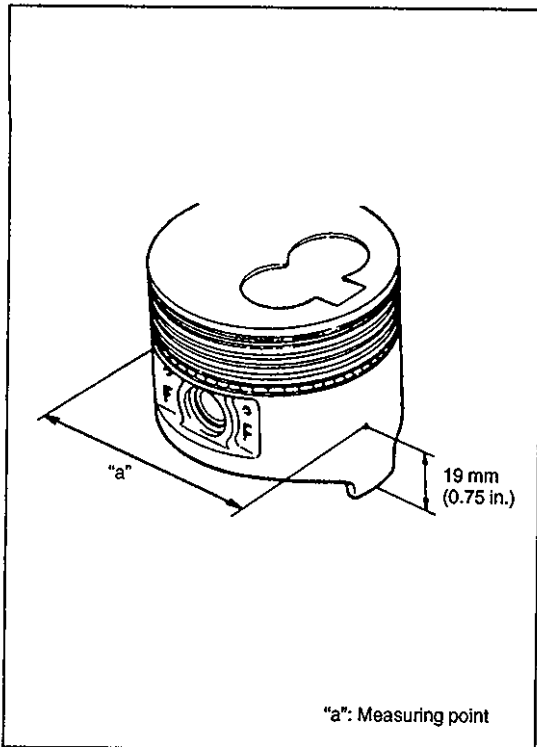

## Piston, Piston Ring, and Piston Pin

### Piston

#### CAUTION:

If piston is replaced, piston rings must also be replaced.

- 1) Inspect outer circumferences of all pistons for seizing and scoring. Replace as necessary.
- 2) Measure outer diameter of each piston at right angle (90°) to piston pin, 19 mm (0.75 in.) above bottom of piston.

#### Piston diameter

Size	mm (in.)	Diameter "a"	mm (in.)
Standard		85.957 – 85.983	(3.3842 – 3.3851)
0.25 (0.010) oversize		86.207 – 86.233	(3.3940 – 3.3949)
0.50 (0.020) oversize		86.457 – 86.483	(3.4039 – 3.4048)

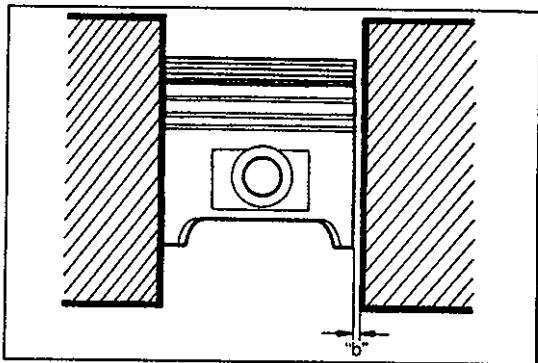

- 3) Measure piston to cylinder clearance.

#### Clearance "b":

**Standard: 0.032 – 0.065 mm (0.0013 – 0.0025 in.)**

**Maximum: 0.15 mm (0.0059 in.)**

If clearance exceeds maximum, replace piston or rebore cylinders to accept oversize pistons.

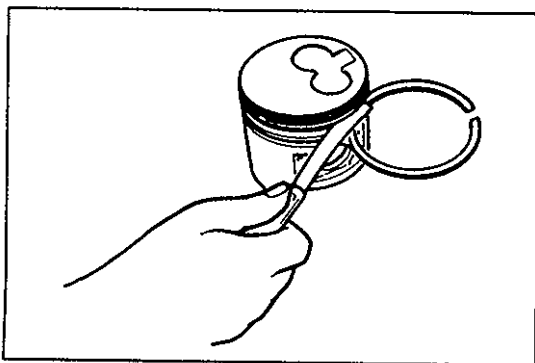

#### Piston and piston rings

- 1) Measure piston ring to ring land clearance around entire circumference of piston by using new piston ring.

#### Top:

**Standard: 0.18 – 0.22 mm (0.0071 – 0.0086 in.)**

#### Second:

**Standard: 0.04 – 0.08 mm (0.0016 – 0.0031 in.)**

**Maximum: 0.2 mm (0.008 in.)**

If clearance exceeds maximum, replace piston.

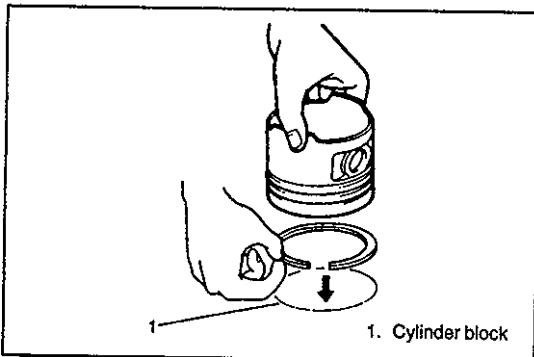

- 2) Inspect piston rings for damage, abnormal wear, and breakage. Replace piston rings if necessary.
- 3) Insert piston ring into cylinder by hand and use piston to push it to bottom of ring travel.

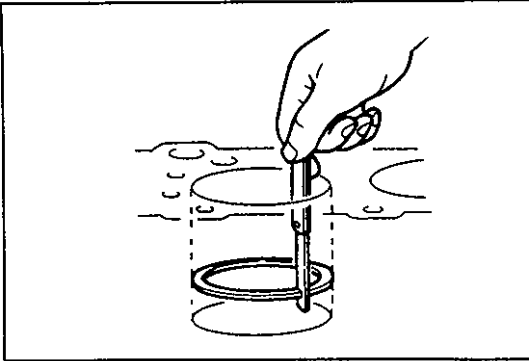

- 4) Measure end gap of each piston ring by using thickness gauge.  
Replace piston rings as necessary.

**Top: 0.20 – 0.30 mm (0.008 – 0.011 in.)**

**Second: 0.20 – 0.30 mm (0.008 – 0.011 in.)**

**Oil rail: 0.20 – 0.30 mm (0.008 – 0.011 in.)**

**Maximum: 1.0 mm (0.039 in.)**

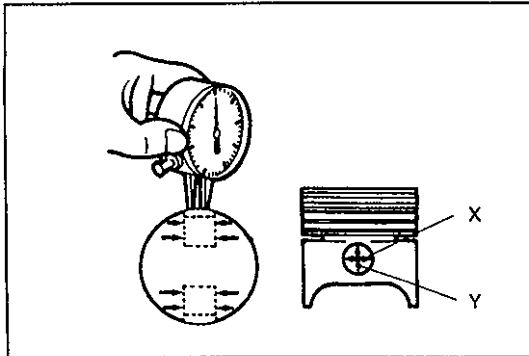

### Piston and piston pin

- 1) Measure each piston pin bore diameter in X and Y directions at four points.

**Diameter: 29.997 – 30.007 mm (1.1810 – 1.1813 in.)**

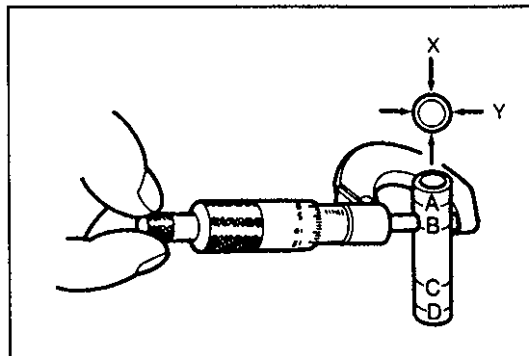

- 2) Measure each piston pin diameter in X and Y directions at four points.

**Diameter: 29.994 – 30.000 mm (1.1809 – 1.1811 in.)**

- 3) Calculate related piston pin to piston clearance.

**Standard: 0.003 – 0.013 mm (0.0001 – 0.0005 in.)**

If clearance exceeds specifications, replace piston and/or piston pin.

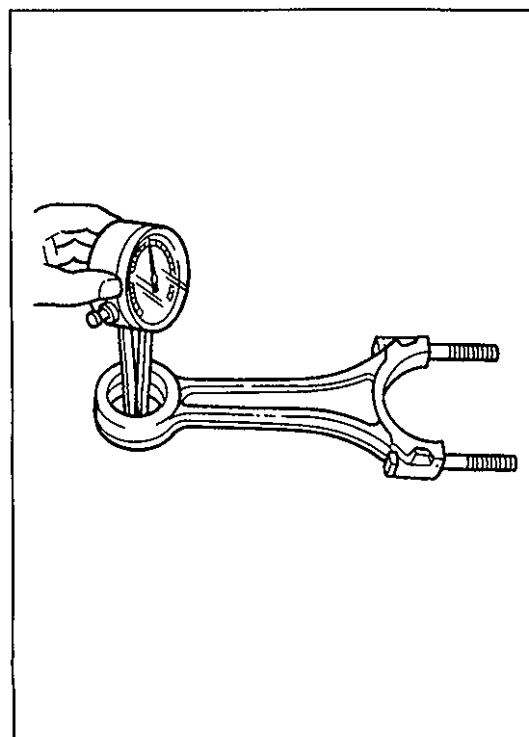

### Connecting Rod

- 1) Measure small end inner diameter of each connecting rod.

**Diameter: 30.014 – 30.030 mm (1.1817 – 1.1822 in.)**

- 2) Calculate clearance between connecting rod small end bore and related piston pin.

**Clearance:**

**Standard: 0.014 – 0.036 mm (0.0006 – 0.0014 in.)**

**Maximum: 0.05 mm (0.002 in.)**

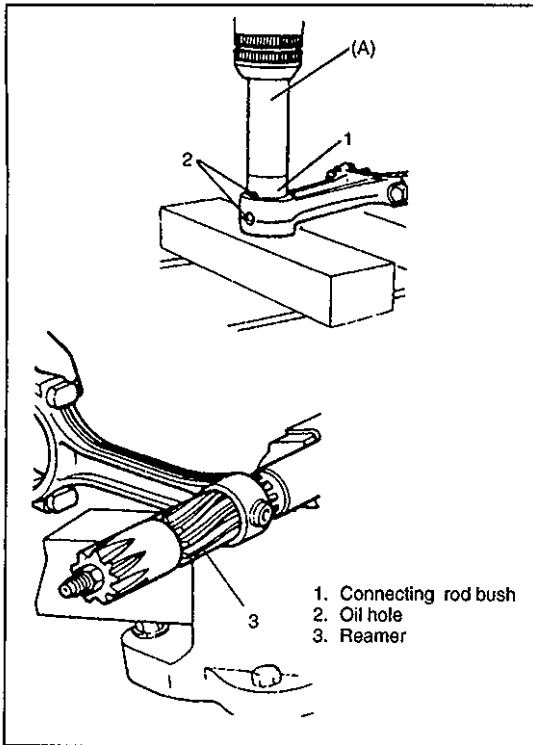

3) If clearance exceeds the maximum, replace the connecting rod bushing by following procedure.

- i) Apply engine oil to connecting rod and bushing.
- ii) Align oil hoses of connecting rod and bushing, and press bushing in by using special tool and press.

**Special Tool**

(A): 09913-80112

- iii) Correct bushing inner diameter, so that clearance is within specification, by using spiral expansion reamer.

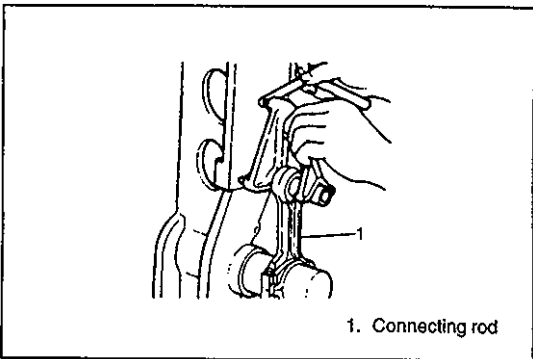

4) Measure each connecting rod for bending. Repair or replace connecting rods as necessary.

**Bending:**

**Maximum: 0.080 mm (0.0031 in.)/50 mm (1.97 in.)**

**Length (Center to Center):**

**151.95 – 152.05 mm (5.9823 – 5.9862 in.)**

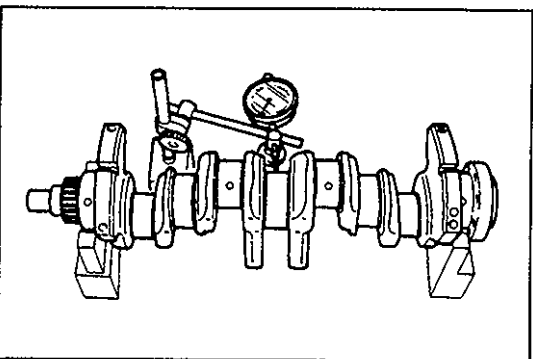

**Crankshaft**

- 1) Check journals and pins for damage, scoring, and oil hole clogging.
- 2) Set crankshaft on V-blocks.
- 3) Measure crankshaft runout at center journal. Replace crankshaft if necessary.

**Runout:**

**Maximum: 0.05 mm (0.002 in.)**

4) Measure each journal diameter in X and Y directions at two points.

**Main journal:**

**Diameter: 59.937 – 59.955 mm (2.3598 – 2.3604 in.)**

**Out-of-round: 0.006 mm (0.0002 in.) max.**

**Crankpin journal:**

**Diameter: 50.940 – 50.955 mm (2.0055 – 2.0060 in.)**

**Out-of-round: 0.006 mm (0.0002 in.) max.**

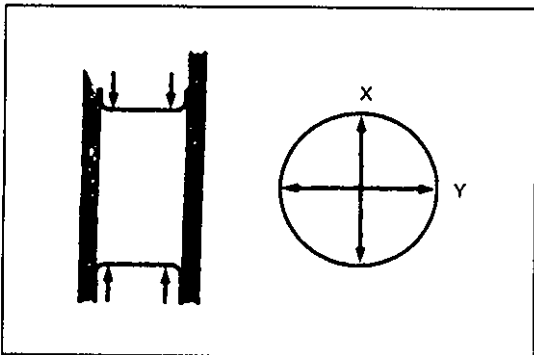

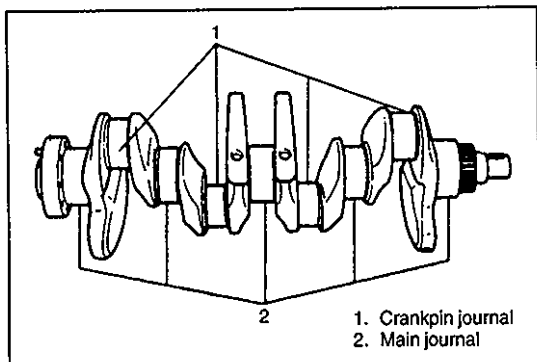

If diameter is less than minimum, grind journals to accept under-size bearings.

**Undersize bearing:**

0.25 mm (0.010 in.), 0.50 mm (0.020 in.)

0.75 mm (0.030 in.)

**CAUTION:**

**Do not remove fillet roll area when grinding.**

**Main journal diameter undersize**

Bearing size	mm (in.)	Journal diameter	mm (in.)
0.25 (0.010) oversize		59.687 – 59.705	(2.3499 – 2.3505)
0.50 (0.020) oversize		59.437 – 59.445	(2.3401 – 2.3403)
0.75 (0.030) oversize		59.187 – 59.205	(2.3302 – 2.3309)

**Crankpin journal diameter undersize**

Bearing size	mm (in.)	Journal diameter	mm (in.)
0.25 (0.010) oversize		50.690 – 50.705	(1.9957 – 1.9962)
0.50 (0.020) oversize		50.440 – 50.445	(1.9859 – 1.9860)
0.75 (0.030) oversize		50.190 – 50.205	(1.9760 – 1.97695)

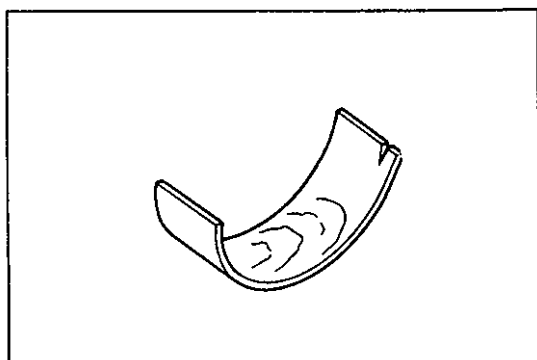

**Bearing**

**Main Bearing, Thrust Bearing and Connecting Rod Bearing**

Check main bearings, thrust bearings and connecting rod bearings for peeling, scoring, and other damage.

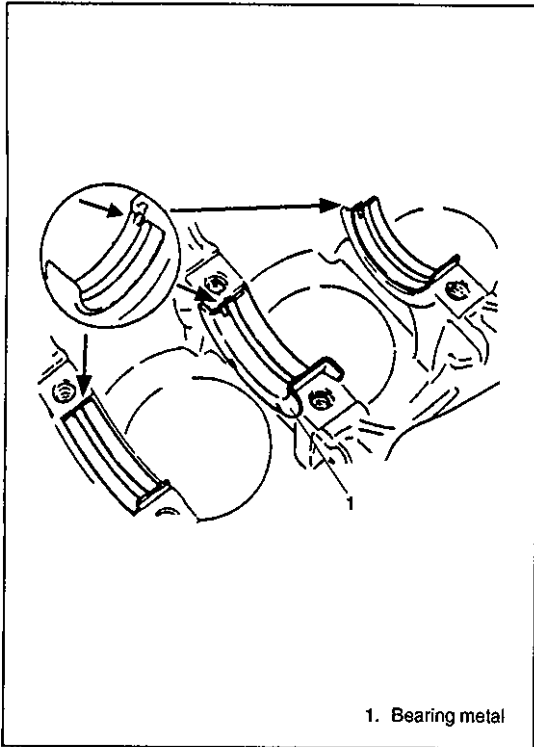

1. Bearing metal

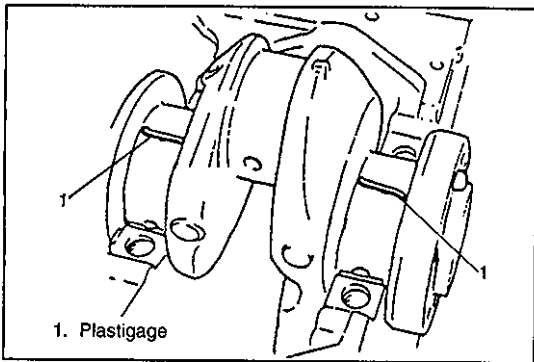

1. Plastigage

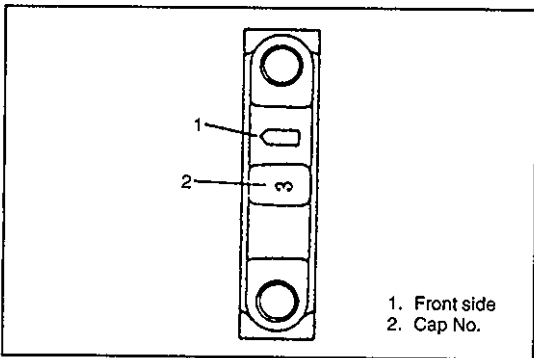

1. Front side  
2. Cap No.

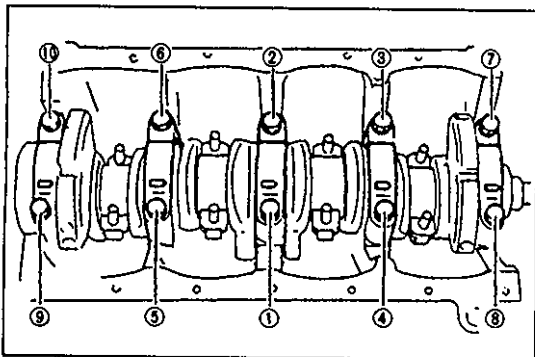

## INSTALLATION

### Crankshaft

- 1) Before installing crankshaft, inspect main bearing oil clearances as follows.

### Oil Clearance Inspection

- i) Remove all foreign material and oil from journals and bearings.

**CAUTION:**

**Install grooved upper main bearings in cylinder block. Install thrust bearings with the oil groove facing crankshaft.**

- ii) Install upper main bearings and thrust bearings.
- iii) Set crankshaft in cylinder block.

**CAUTION:**

**Do not rotate crankshaft when measuring oil clearances.**

- iv) Position plastigage stop journals in axial direction.

- v) Install lower main bearings and main bearing caps according to cap number, facing the  mark forward.

- vi) Tighten main bearing cap bolts in two or three steps in order shown in figure.

**Tightening Torque for Main Bearing Cap Bolt:**

**87 N·m (8.7 kg-m, 63 lb-ft)**

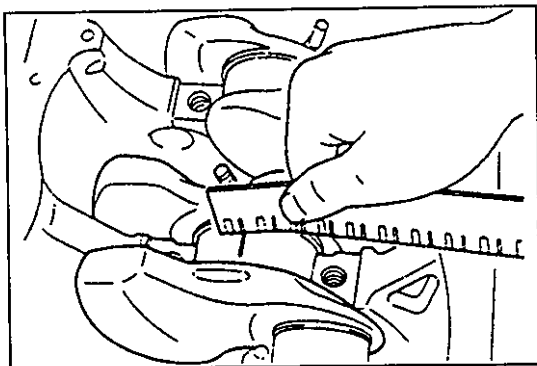

- vii) Remove main bearing caps, and measure plastigage at each journal at widest point for smallest clearance, and at narrowest point for largest clearance.
- viii) If oil clearance exceeds specifications, grind crankshaft and install undersize main bearings. (Refer to pages 6A3-52 and 53.)

**Oil clearance:**

**Standard: 0.031 – 0.050 mm (0.0012 – 0.0019 in.)**

**Maximum: 0.008 mm (0.0031 in.)**

Bearing size mm (in.)	Thickness (mm (in.))	Main Journal diameter (mm (in.))
Standard	2 <sup>+0.007</sup> <sub>-0.004</sub> (0.0787 <sup>+0.0003</sup> <sub>-0.0002</sub> )	59.937 – 59.955 (2.3597 – 2.3604)
0.25 (0.010) undersize	2.125 <sup>+0.014</sup> <sub>-0.004</sub> (0.0836 <sup>+0.0006</sup> <sub>-0.0002</sub> )	59.687 – 59.691 (2.3499 – 2.3500)
0.50 (0.020) undersize	2.250 <sup>+0.014</sup> <sub>-0.004</sub> (0.0886 <sup>+0.0006</sup> <sub>-0.0002</sub> )	59.437 – 59.441 (2.3400 – 2.3402)
0.75 (0.030) undersize	2.375 <sup>+0.014</sup> <sub>-0.004</sub> (0.0935 <sup>+0.0006</sup> <sub>-0.0002</sub> )	59.187 – 59.191 (2.3302 – 2.3304)

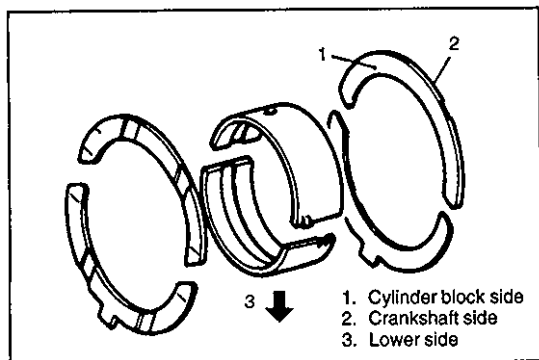

- 2) Apply clean engine oil to main bearings, thrust bearings and main journals.

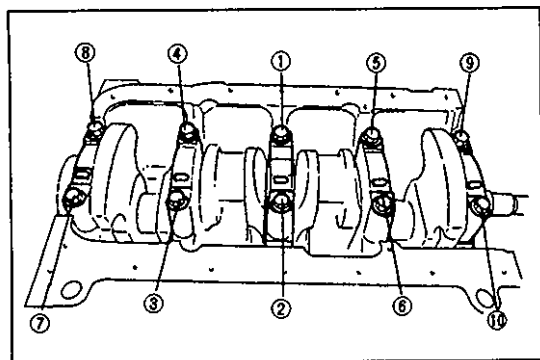

- 3) Install main bearing caps according to cap number, facing the mark toward the front.
- 4) Tighten main bearing cap bolts in two or three steps in order shown in figure.

**Tightening Torque for Main Bearing Cap Bolt:**  
**87 N·m (8.7 kg-m, 63 lb-ft)**

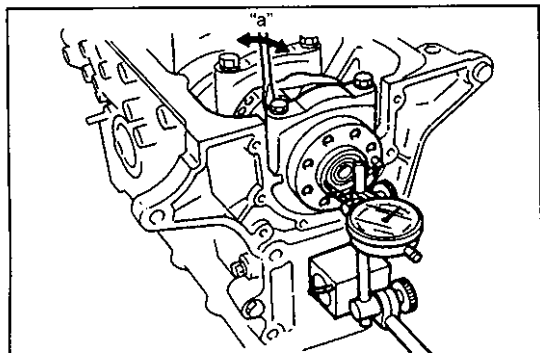

- 5) Measure crankshaft end play.

**End play "a":**

**Standard: 0.040 – 0.282 mm (0.0016 – 0.0111 in.)**

**Maximum: 0.30 mm (0.012 in.)**

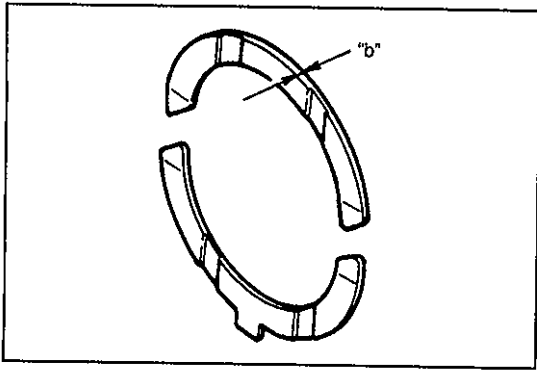

If end play exceeds maximum, grind crankshaft and install over-size thrust bearings, or replace crankshaft and thrust bearings.

**Thrust bearing width "b":**

**Standard: 2.00 – 2.05 mm (0.0788 – 0.0807 in.)**

**Oversize: 2.175 – 2.225 mm (0.0857 – 0.0875 in.)**

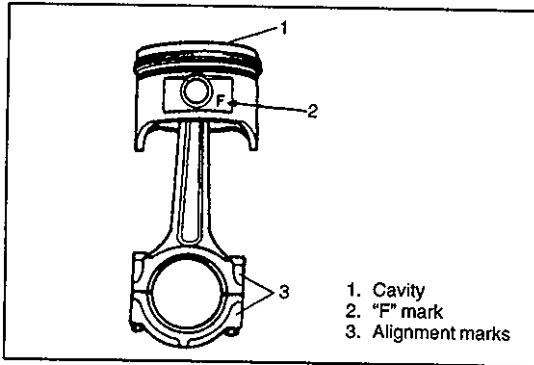

**Connecting Rod**

- 1) Align piston cavity and matching mark in large end of connecting rod.
- 2) Apply engine oil to circumference of each piston pin and to small end of each connecting rod.

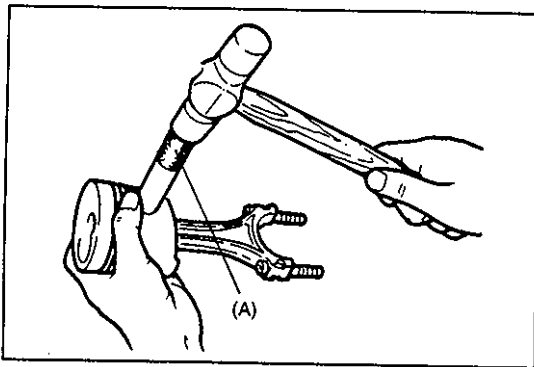

- 3) Insert a snap ring into one of the piston pin holes in piston.
- 4) Install piston pin by using special tool.

**Special Tool**

**(A): 09910-37860**

- 5) Connect piston and connecting rod by piston pin, and lock snap ring.

**NOTE:**

**Heat the piston to 50 – 70°C (122 – 158°F) for installation.**

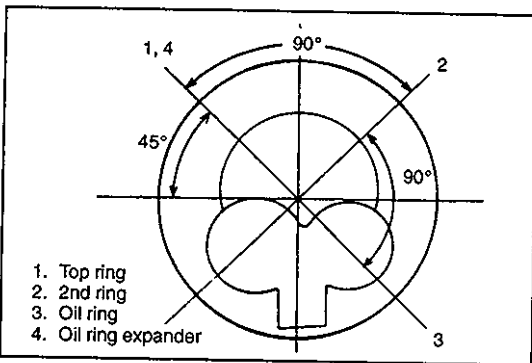

**Piston Ring**

- 1) Apply clean engine oil to piston rings.
- 2) Install oil ring expander and oil ring.
- 3) Install second ring.
- 4) Install top ring.
- 5) Align piston ring end gaps, as shown in figure.

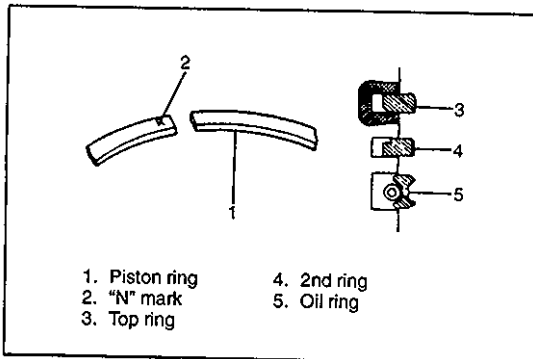

**CAUTION:**  
The rings must be mounted so "N" marks face upward.

1. Piston ring
2. "N" mark
3. Top ring
4. 2nd ring
5. Oil ring

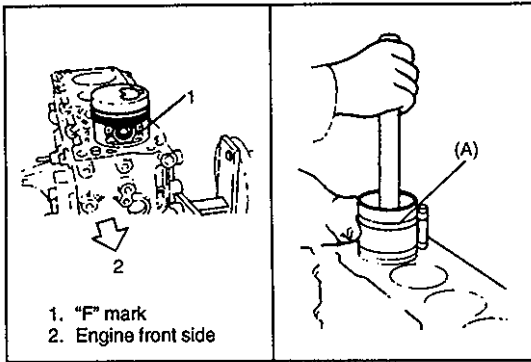

### Piston and Connecting Rod

- 1) Apply clean engine oil to cylinder walls, pistons, and piston rings.
- 2) Check piston rings for correct end gap alignment.
- 3) Using piston ring compressor insert each piston assembly into cylinder block with "F" mark facing front of engine.

#### Special Tool

(A): 09916-77310

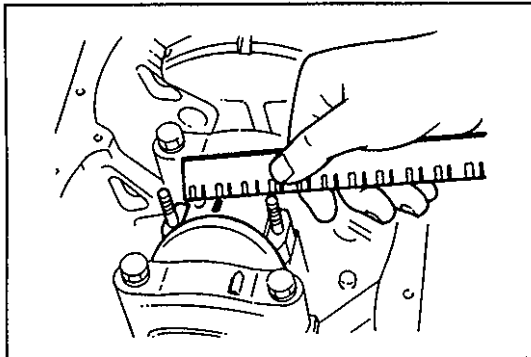

### Connecting Rod Cap

- 1) Measure connecting rod bearing oil clearance using the same procedure as for main bearing oil clearance.

**Tightening Torque for Connecting Rod Cap Nut:**  
65 N·m (6.5 kg-m, 47 lb-ft)

#### Oil clearance:

**Standard:** 0.027 – 0.055 mm (0.0011 – 0.0021 in.)

**Maximum:** 0.08 mm (0.0031 in.)

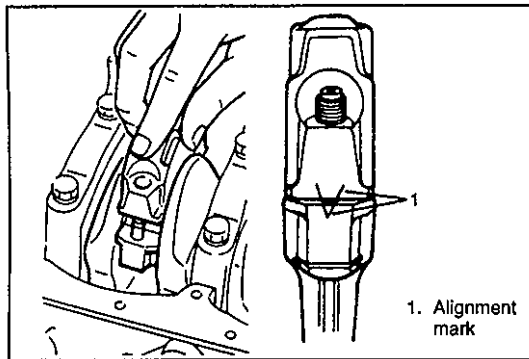

#### CAUTION:

**Align alignment marks on the cap and on connecting rod when installing connecting rod cap.**

If oil clearance exceeds maximum, grind crankshaft to accept undersize bearings. (Refer to pages 6A3-52 and 53.)

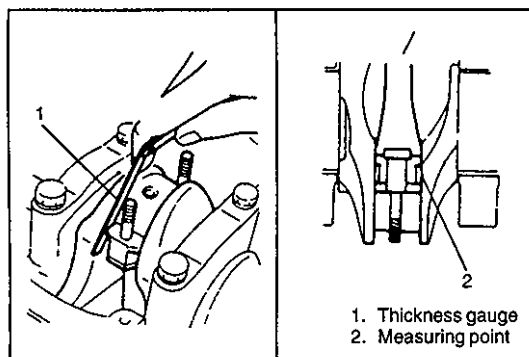

- 2) Measure connecting rod side clearances.

#### Side clearance:

**Standard:** 0.110 – 0.262 mm (0.0044 – 0.0103 in.)

**Maximum:** 0.35 mm (0.014 in.)



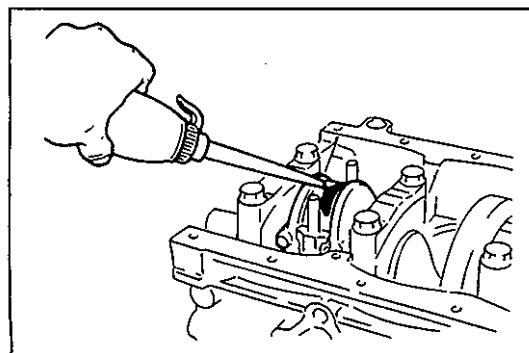



If clearance exceeds maximum, replace connecting rod and cap.

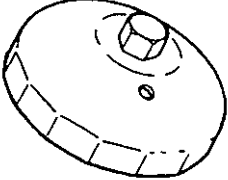
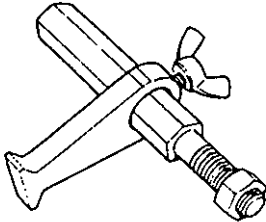
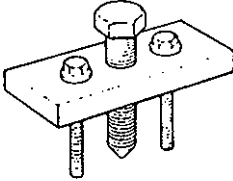
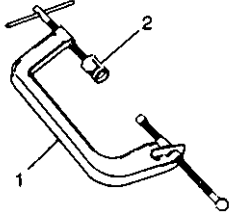
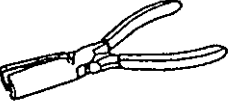

- 3) Apply clean engine oil to crankpin journals and connecting rod bearings.
- 4) Install connecting rod caps with alignment marks aligned.
- 5) Tighten connecting rod cap nuts.

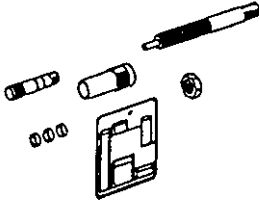
**Tightening Torque for Connecting Rod Cap Nut:**  
65 N·m (6.5 kg-m, 47 lb-ft)

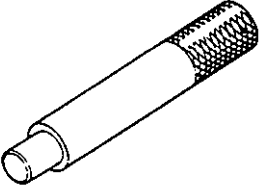
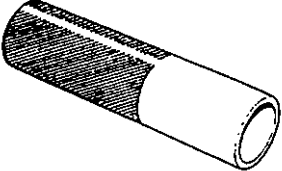
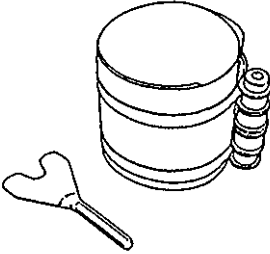
## SPECIAL TOOLS

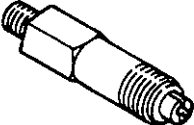
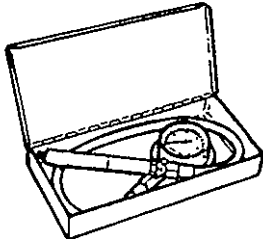
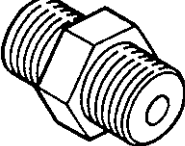
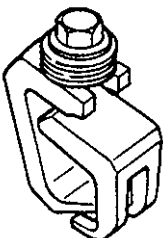
 <p>09915-47810 Oil filter wrench</p>	 <p>09924-17810 Flywheel holder</p>	 <p>09944-36011 Steering wheel remover</p>	 <p>1. 09916-14510 Valve lifter 2. 09916-48210 Attachment</p>
 <p>09916-47810 Valve seal remover</p>	 <p>09916-46010 Valve guide remover</p>	 <p>09916-57810 Valve seal and valve guide installer set</p>	 <p>09950-76010 Flare nut wrench (17 – 19 mm)</p>
 <p>09910-37860 Piston pin replacer</p>	 <p>09913-80112 Bearing installer</p>	 <p>09916-77310 Piston ring compressor</p>	 <p>09912-57820 Compression gauge</p>
 <p>09912-57830 Compression gauge attachment</p>	 <p>09915-77310 Oil pressure gauge</p>	 <p>09915-78210 Oil pressure gauge attachment</p>	 <p>09916-67810 Tappet holder</p>

**REQUIRED SERVICE MATERIALS**

MATERIAL	RECOMMENDED SUZUKI PRODUCT	USE
Sealant	SUZUKI BOND NO.1207C (99000-31150)	<ul style="list-style-type: none"><li>● To oil pressure switch.</li><li>● To apply to mating surfaces of cylinder head and cylinder head cover.</li><li>● To apply to mating surfaces of cylinder block, oil baffle plate and oil pan.</li><li>● To apply to mating surfaces of cylinder block and oil pump.</li></ul>
Sealant	SUZUKI BOND NO.1215 (99000-31110)	<ul style="list-style-type: none"><li>● To apply to mating surface of cylinder block, cylinder head.</li></ul>
Thread lock cement	THREAD LOCK CEMENT SUPER 1322 (99000-32110)	<ul style="list-style-type: none"><li>● To flywheel (M/T) or drive plate (A/T) bolts.</li></ul>

## SECTION 6B

## ENGINE COOLING

**NOTE:**

For the descriptions (items) not found in this section, refer to the same section of the Service Manual mentioned in FOREWORD of this manual.

## CONTENTS

<b>GENERAL DESCRIPTION</b> .....	6B- 2
Cooling System Circulation .....	6B- 2
Thermostat .....	6B- 3
Cooling Fan Clutch .....	6B- 3
Coolant .....	6B- 4
<b>MAINTENANCE</b> .....	6B- 5
Cooling System Flush and Refill .....	6B- 5
Fan (Generator) Belt Tension Check and Adjustment .....	6B- 6
<b>ON-VEHICLE SERVICE</b> .....	6B- 7
Radiator and Cooling Fan .....	6B- 7
Thermostat .....	6B- 9
Water Pump .....	6B-10
<b>REQUIRED SERVICE MATERIAL</b> .....	6B-11
<b>TIGHTENING TORQUE SPECIFICATIONS</b> .....	6B-11

## GENERAL DESCRIPTION

The cooling system consists of the radiator cap, radiator, coolant reservoir, hoses, water pump, cooling fan, and thermostat. The radiator is of tube-and-fin type.

### WARNING:

- Do not remove radiator cap to check engine coolant level; check coolant visually at the see-through coolant reservoir.  
Coolant should be added only to reservoir as necessary.
- As long as there is pressure in the cooling system, the temperature can be considerably higher than the boiling temperature of the solution in the radiator without causing the solution to boil. Removal of the radiator cap while engine is hot and pressure is high will cause the solution to boil instantaneously and possibly with explosive force, spewing the solution over engine, fenders and person removing cap. If the solution contains flammable anti-freeze such as alcohol (not recommended for use at any time), there is also the possibility of causing a serious fire.

## COOLING SYSTEM CIRCULATION

- 1) While the engine is warmed up (thermostat closed), coolant circulates as follows.

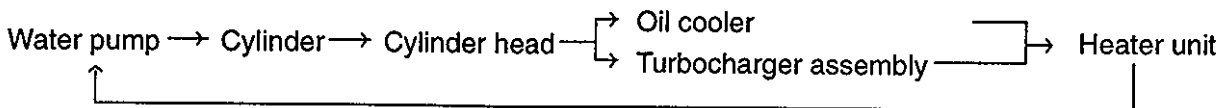

- 2) When coolant is warmed up to normal temperature and the thermostat opens, coolant passes through the radiator core to be cooled as well as the above flow circuit.

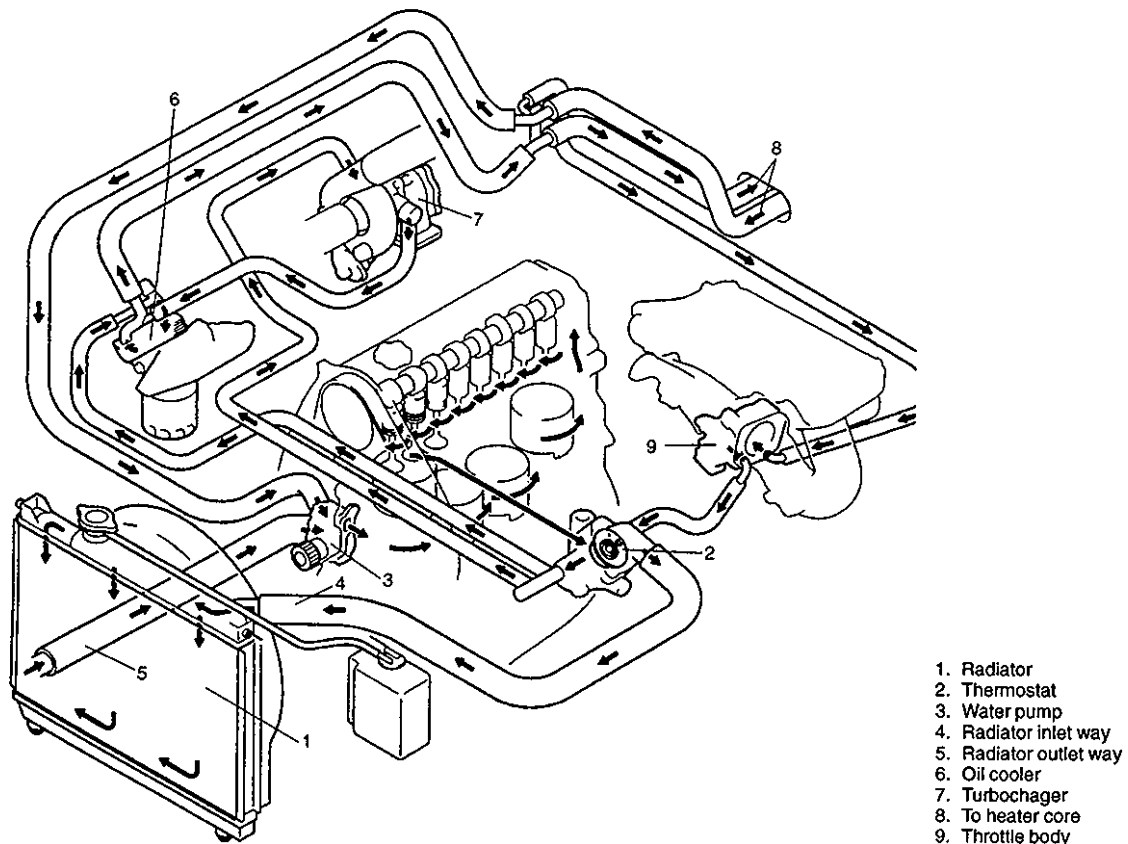

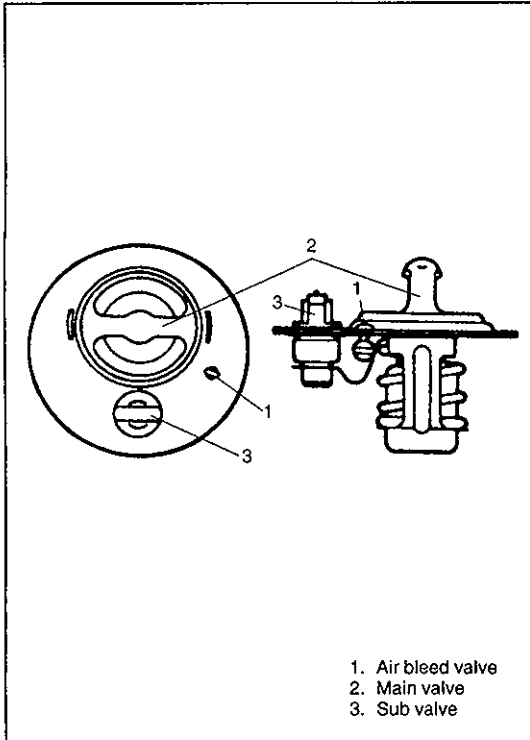

## THERMOSTAT

Temp. at which valve begins to open	Main valve	$88 \pm 1.5^{\circ}\text{C}$ ( $189 \pm 2^{\circ}\text{F}$ )
	Sub valve	$80 \pm 1.5^{\circ}\text{C}$ ( $176 \pm 2^{\circ}\text{F}$ )
Temp. at which valve becomes fully open	Main valve	$100^{\circ}\text{C}$ ( $212^{\circ}\text{F}$ )
	Sub valve	
Valve lift	Main valve	More than 8 mm (0.31 in.) at $95^{\circ}\text{C}$
	Sub valve	More than 1.5 mm (0.06 in.) at $100^{\circ}\text{C}$

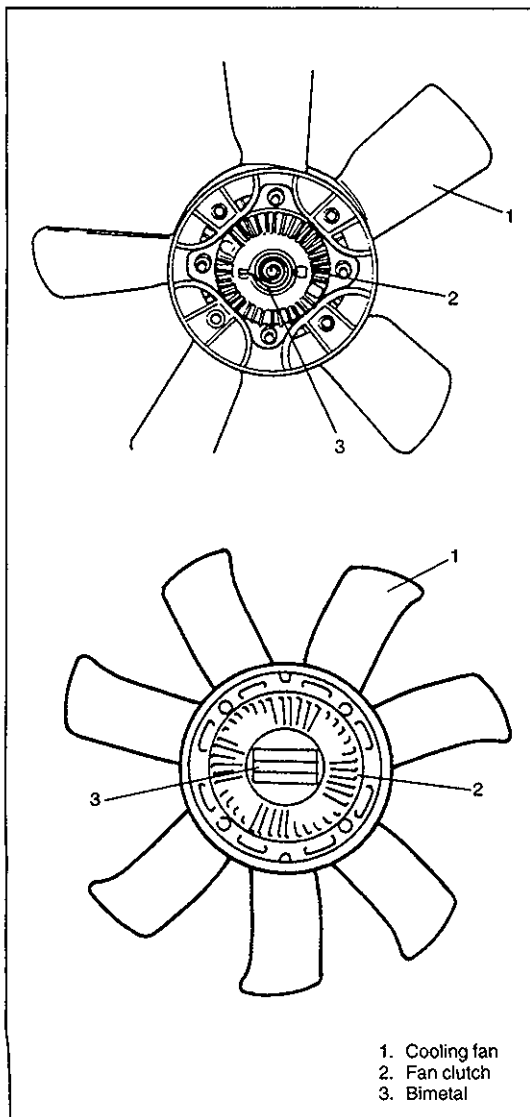

## COOLING FAN CLUTCH

Fluid is enclosed in the cooling fan clutch and at its center front, there is a bimetal whose thermal reaction and the engine speed control the cooling fan speed.

The relation between the temperature detected by the fan clutch and operation of the fan clutch is as follows.

While the fan clutch detects a temperature lower than  $80^{\circ}\text{C}$ , it remains OFF and the fan revolution speed is constant (1,200 r/min. (rpm)) regardless of the engine speed. As the temperature reaches  $80^{\circ}\text{C}$  to  $95^{\circ}\text{C}$ , the fan clutch turns ON gradually and the fan revolution speed increases.

A temperature exceeding  $95^{\circ}\text{C}$  causes the fan clutch to turn ON and the fan revolution speed to increase in proportion with the engine speed.

Once the engine speed exceeds a specified one, however, the fan revolution speed becomes constant (3,600 r/min. (rpm)).

### NOTE:

Do not disassemble fan clutch.

ANTI-FREEZE PROPORTIONING CHART			
Freezing temperature	°C	-16	-36
	°F	3	-33
Antifreeze/Anti-corrosion coolant concentration	%	30	50
Ratio of compound to cooling water	ltr.	2.0/4.6	3.3/3.3
	US pt.	4.2/9.7	7.0/7.0
	Imp. pt.	3.5/8.1	5.8/5.8
COOLANT CAPACITY			
Engine, radiator and heater	5.7 liters (12.0/10.0 US/Imp. pt.)		
Reservoir	0.9 liters (1.9/1.6 US/Imp. pt.)		
Total	6.6 liters (13.9/11.6 US/Imp. pt.)		

## COOLANT

The coolant recovery system is standard. The coolant in the radiator expands with heat, and the overflow is collected in the reservoir. When the system cools down, the coolant is drawn back into the radiator.

The cooling system has been filled at the factory with a quality coolant that is a 50/50 mixture of water and ethylene glycol antifreeze.

This 50/50 mixture coolant solution provides freezing protection to  $-36^{\circ}\text{C}$  ( $-33^{\circ}\text{F}$ ).

- Maintain cooling system freeze protection at  $-36^{\circ}\text{C}$  ( $-33^{\circ}\text{F}$ ) to ensure protection against corrosion and loss of coolant from boiling. This should be done even if freezing temperatures are not expected.
- Add ethylene glycol base coolant when coolant has to be added because of coolant loss or to provide added protection against freezing at temperature lower than  $-36^{\circ}\text{C}$  ( $-33^{\circ}\text{F}$ ).

### NOTE:

- Alcohol or methanol base coolant or plain water alone should not be used in cooling system at any time as damage to cooling system could occur.
- Even in a market where no freezing temperature is anticipated, mixture of 70% water and 30% ethylene glycol antifreeze (Antifreeze/Anticorrosion coolant) should be used for the purpose of corrosion protection and lubrication.
- "Hard water", if used, will foul up the cooling circuit by scale formation. Tap water available from city water supply is the best available water, in a practical sense, for the cooling system. Distilled water is ideal but is a luxury in most cases.

## MAINTENANCE

### COOLING SYSTEM FLUSH AND REFILL

- 1) Remove radiator cap when engine is cool.  
Turn cap slowly to the left until it reaches a "stop" (Do not press down while turning it).  
Wait until pressure is relieved (indicated by a hissing sound) then press down on cap and continue to turn it to the left.

**WARNING:**

**To help avoid danger of being burned, do not remove radiator cap while engine and radiator are still hot. Scalding fluid and steam can be blown out under pressure if cap is taken off too soon.**

- 2) With radiator cap removed, run engine until upper radiator hose is hot (this shows that thermostat is open and coolant is flowing through system).

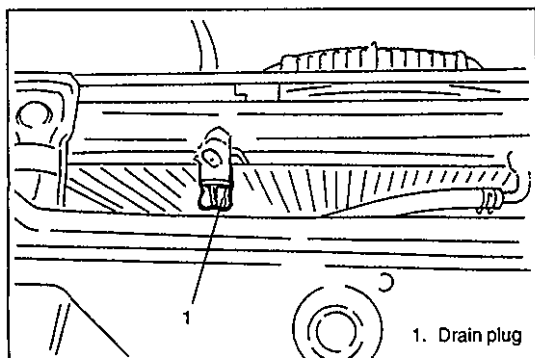

- 3) Stop engine and open radiator drain plug to drain coolant.
- 4) Close drain plug. Add water until system is filled and run engine until upper radiator hose is hot again.
- 5) Repeat steps 3) and 4) several times until drained liquid is nearly colorless.
- 6) Drain system and then close radiator drain plug tightly.

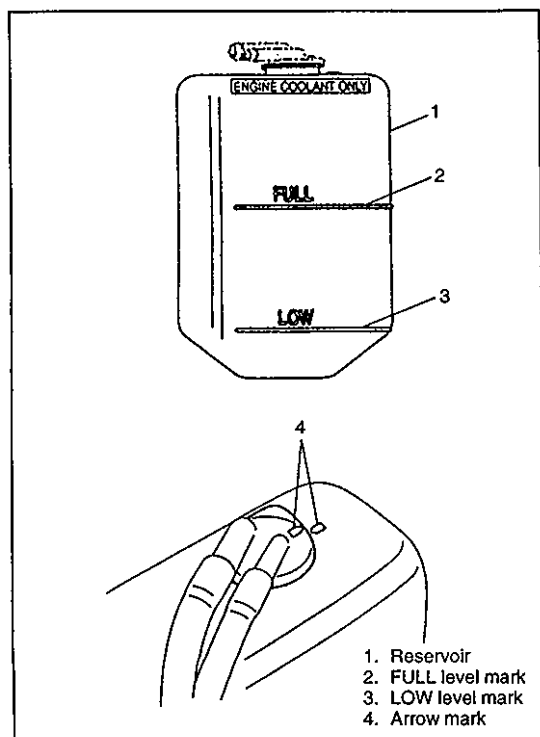

- 7) Disconnect hose from reservoir. Remove reservoir and pour out any fluid. Scrub and clean inside of reservoir with soap and water. Flush it well with clean water and drain. Reinstall reservoir and hose.
- 8) Add 50/50 mixture of good quality ethylene glycol antifreeze and water to radiator and tank. Fill radiator to the base of radiator filler neck and reservoir to "FULL" level mark.

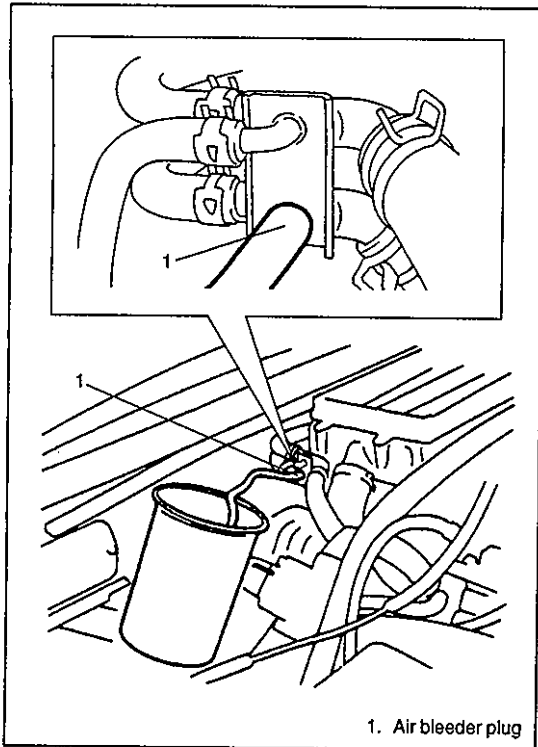

- 9) After removing air bleeder plug cap, connect hose to air bleeder plug and place a container to receive coolant which will flow from connected hose.
- 10) Start engine and keep it running till coolant flows out of hose connected in Step 9) continuously. Then stop engine, disconnect hose and install air bleeder plug cap securely.
- 11) Run engine, with radiator cap removed, until radiator upper hose is hot.
- 12) With engine idling, add coolant to radiator until level reaches the bottom of filler neck. Install radiator cap, making sure that the ear of cap lines up with reservoir hose.
- 13) Stop engine. After waiting until engine is cold, fill coolant to reservoir until "FULL" level mark.
- 14) Reinstall reservoir cap, aligning the arrow marks on the reservoir and cap.

## FAN (GENERATOR) BELT TENSION CHECK AND ADJUSTMENT

### WARNING:

Disconnect negative cable at battery before checking and adjusting belt tension.

- 1) Inspect belt for cracks, cuts, deformation, wear and cleanliness. If it is necessary to replace belt, refer to Section 6H for procedure.
- 2) Check belt for tension. Belt is in proper tension when it deflects 15 to 17 mm (0.59 – 0.67 in.) under thumb pressure (about 10 kg or 22 lb.).

**Belt tension: 15 – 17 mm (0.59 – 0.67 in.)  
as deflection/10 kg (22 lbs)**

### Tightening torque

- (a): 23 N·m (2.3 kg-m, 16.0 lb-ft)  
(b): 45 N·m (4.5 kg-m, 32.5 lb-ft)

### NOTE:

When replacing belt with a new one, adjust belt tension to 8 – 10 mm (0.31 – 0.39 in.).

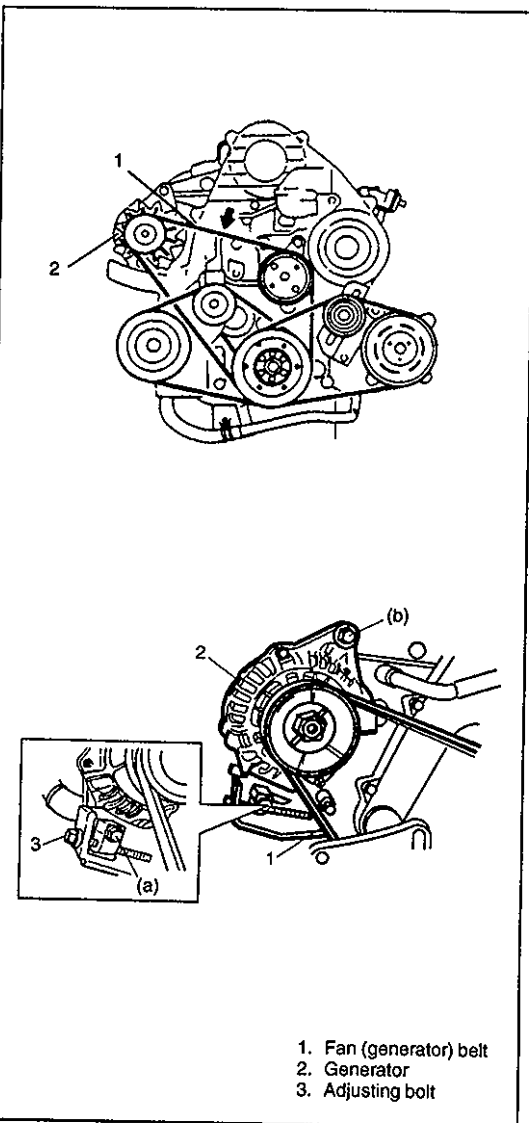

## ON-VEHICLE SERVICE

**WARNING:**

- Check to make sure that engine coolant temperature is cold before removing any part of cooling system.
- Also be sure to disconnect negative cable from battery terminal before removing any part.

**NOTE:**

Refill cooling system with proper coolant referring to "Coolant" and steps 8) to 14) of "Cooling System Flush and Refill" in this section.

### RADIATOR AND COOLING FAN

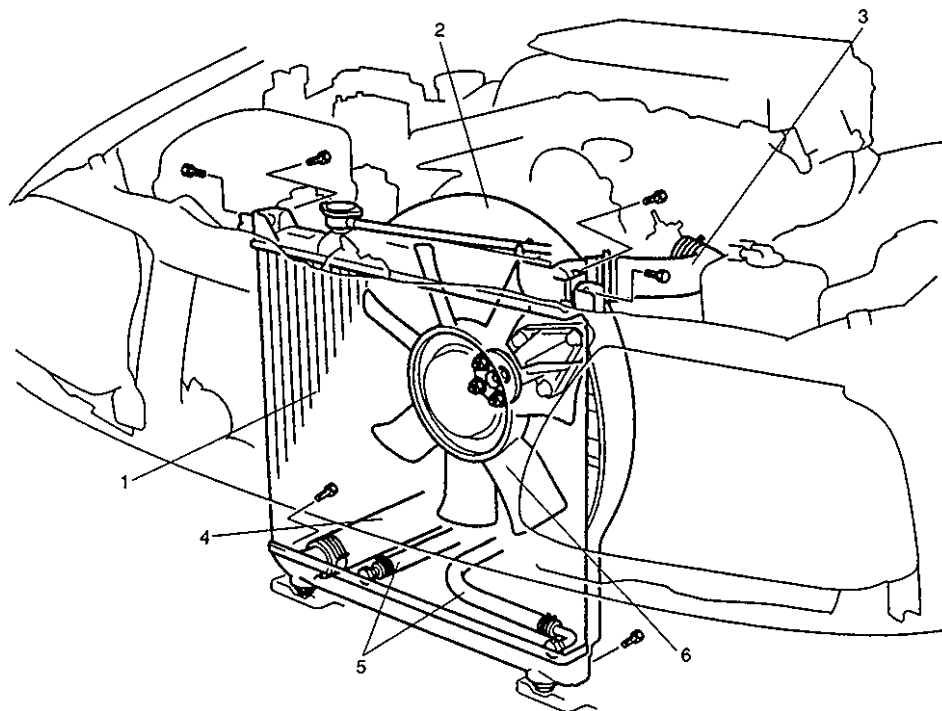

1. Radiator
2. Shroud
3. Radiator inlet hose
4. Radiator outlet hose
5. Oil hose (for A/T)
6. Cooling fan

**REMOVAL**

- 1) Loosen drain plug on radiator to drain coolant.
- 2) After draining coolant, be sure to tighten drain plug securely.
- 3) Disconnect radiator outlet pipe.
- 4) Remove cooling fan/clutch and radiator shroud.

**WARNING:**

Be careful not to damage radiator fins.

- 5) Remove radiator.

**INSTALLATION**

Install removed parts in reverse order of removal procedure. After installation, adjust belt tension for specification and tighten each bolt and nut securely.

**NOTE:**

- Refill cooling system with proper coolant referring to “Coolant” and steps 8) to 14) of “Cooling System Flush and Refill” in this section.
- After installation, check each joint for leakage.

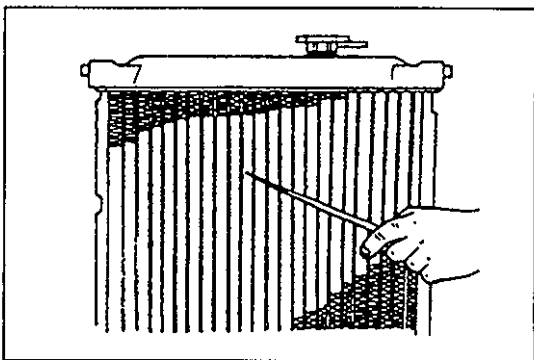
**INSPECTION****Radiator**

Check for following and repair or replace as necessary.

- Cracks, damage, and water leakage
- Bent fins (Repair with a screwdriver.)
- Distorted and bent radiator inlet and outlet

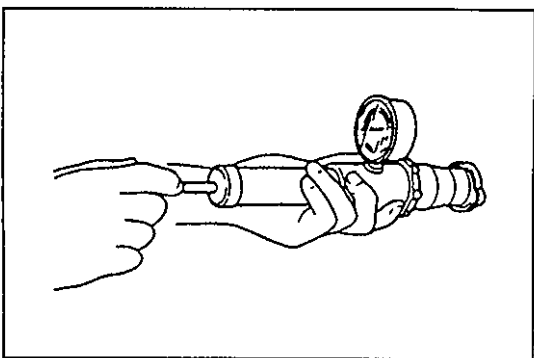
**Radiator cap valve**

- 1) Remove all foreign material (such as water residue) from between radiator cap valve and valve seat.
- 2) Attach radiator cap to a radiator cap tester (commercially available). Apply pressure gradually to 93 – 123 kPa (0.94 – 1.25 kgf/cm<sup>2</sup>, 13.4 – 17.74 psi).
- 3) Verify that pressure is held for at least 10 seconds.

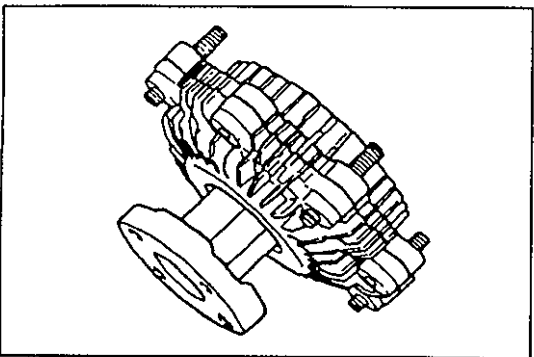
**Fluid coupling**

Check fluid coupling for oil leakage. Replace the fan clutch if necessary.

**WARNING:**

Fan clutch cannot be disassembled.

## THERMOSTAT

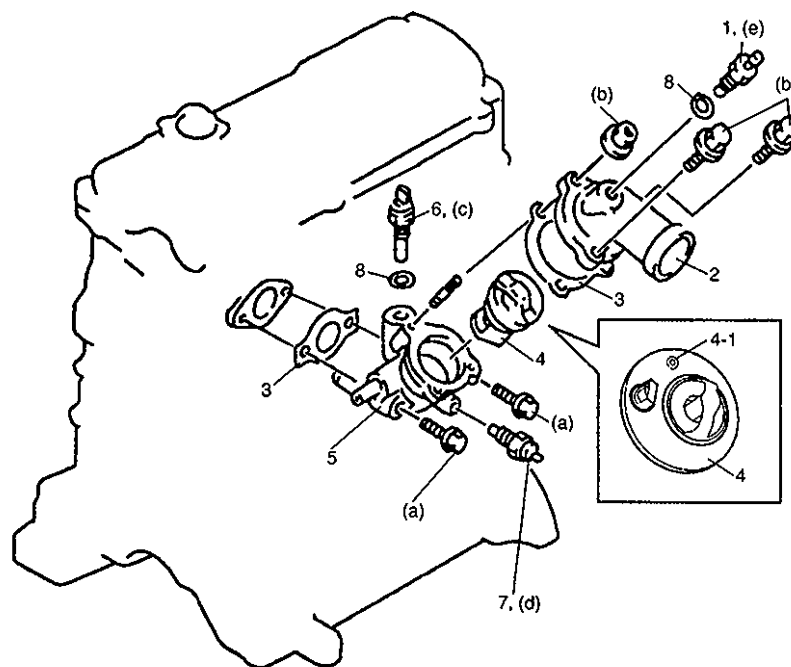

- |                      |                         |
|----------------------|-------------------------|
| 1. ECT gauge         | 6. ECT sensor (for ECM) |
| 2. Thermostat cap    | 7. ECT sensor (for A/C) |
| 3. Gasket            | 8. O-ring               |
| 4. Thermostat        |                         |
| 4-1. Air bleed valve |                         |
| 5. Thermostat case   |                         |

### REMOVAL AND INSTALLATION

- Remove in order shown in figure.
- For installation, reverse removal procedure and use new gasket.
- Install thermostat with its air bleed valve facing up (as shown in figure).
- Tighten sensor, bolt and nut to specified torque.

#### Tightening torque

- (a): 23 N·m (2.3 kg-m, 16.5 lb-ft)
- (b): 10 N·m (1.0 kg-m, 7 lb-ft)
- (c): 28 N·m (2.8 kg-m, 20 lb-ft)
- (d): 15 N·m (1.5 kg-m, 11 lb-ft)
- (e): 8 N·m (0.8 kg-m, 6 lb-ft)

#### NOTE:

- Refill cooling system with proper coolant referring to "Coolant" and steps 8) to 14) of "Cooling System Flush and Refill" in this section.
- After installation, check each joint for leakage.

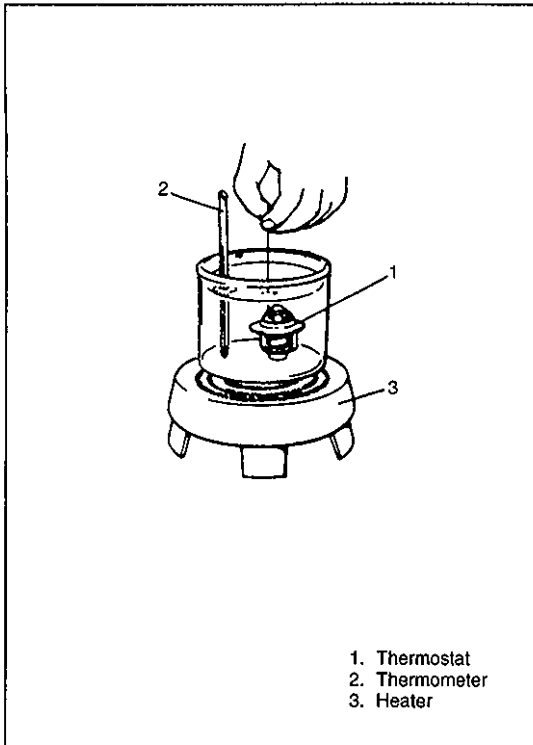

## INSPECTION

- 1) Visually check that thermostat valve is airtight.
- 2) Place thermostat and a thermometer in water.
- 3) Heat water and check following.

### Valve opening temperature

Sub valve: 78.5 – 81.5°C (173–179°F)

Main valve: 86.5 – 89.5°C (186–193°F)

Full open temperature: 100°C (212°F)

### Full open lift

Sub valve: 1.5 mm ( 0.06 in.)

Main valve: 8 mm ( 0.31 in.)

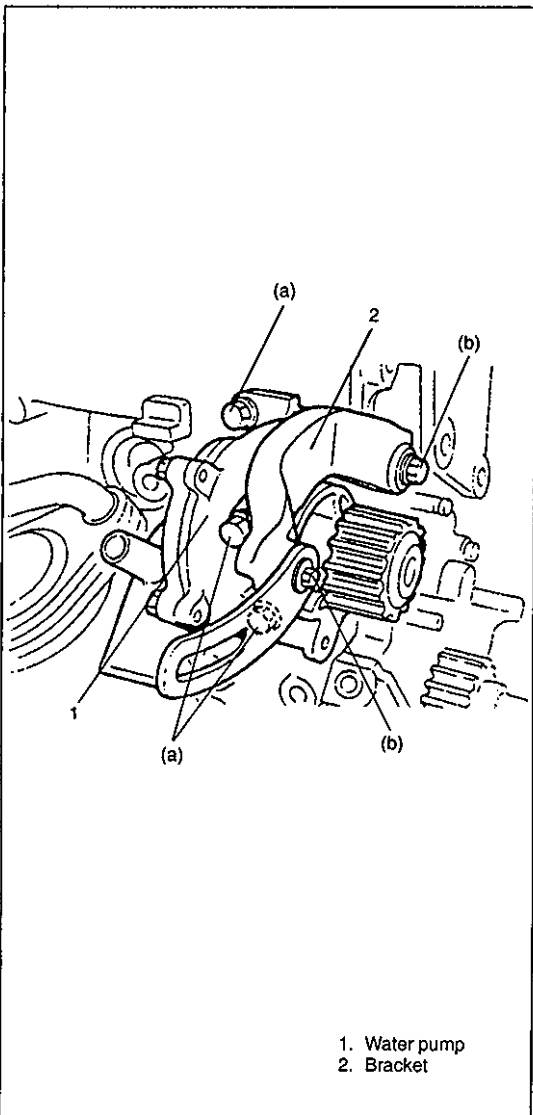

## WATER PUMP

### REMOVAL AND INSTALLATION

- Remove in order shown in figure.
- For installation, reverse removal procedure.
- Use new gasket so that printed side of gasket faces water pump.
- Tighten bolt to specified torque.

### Tightening torque

(a): 45 N·m (4.5 kg·m, 32.5 lb-ft)

(b): 23 N·m (2.3 kg·m, 16.5 lb-ft)

### NOTE:

- Refill cooling system with proper coolant referring to “Coolant” and steps 8) to 14) of “Cooling System Flush and Refill” in this section.
- After installation, check each joint for leakage.

## INSPECTION

### NOTE:

**Do not disassemble water pump.**

**If any repair is required on pump, replace it as assembly.**

- 1) Rotate water pump by hand to check for smooth operation. If pump does not rotate smoothly or makes abnormal noise, replace it.
- 2) Inspect water pump impeller for damage. Replace as necessary.

### NOTE:

**Do not disassemble water pump to check the water pump impeller.**

## REQUIRED SERVICE MATERIAL

MATERIALS	USE
Ethylene glycol base coolant (Anti-freeze/Anti-corrosion coolant)	Additive to engine cooling system for improving cooling efficiency and for protection against rusting.

## TIGHTENING TORQUE SPECIFICATIONS

Fastening parts		Tightening torque		
		N·m	kg-m	lb-ft
Generator mounting bolt	Upper side	45	4.5	32.5
	Lower side	23	2.3	16.5
Water pump bolt	Mounting	23	2.3	16.5
	Bracket	45	4.5	32.5
Thermostat cap bolt and nut		10	1.0	7
Thermostat case bolt		23	2.3	16.5
ECT sensor (for ECM)		28	2.8	20
ECT sensor (for A/C)		15	1.5	11
ECT gauge		8	0.8	6

## SECTION 6C

# ENGINE FUEL

**NOTE:**

For the descriptions (items) not found in this section, refer to the same section of the Service Manual mentioned in FOREWORD of this manual.

### CONTENTS

<b>GENERAL DESCRIPTION</b> .....	6C-1	Injection Pump .....	6C-3
Fuel System .....	6C-1	Fuel Filter .....	6C-3
<b>ON-VEHICLE SERVICE</b> .....	6C-2	Fuel Filler Cap .....	6C-4
Water Draining of Fuel System .....	6C-2	2-way Check Valve .....	6C-4
Air Bleeding of Fuel System .....	6C-2	Fuel Tank .....	6C-4
Replacement of Fuel Filter Cartridge ....	6C-2	<b>TIGHTENING TORQUE SPECIFICATION</b> ...	6C-6

6C

## GENERAL DESCRIPTION

### FUEL SYSTEM

The main components of the fuel system are fuel tank, fuel injection pump, fuel filter and fuel level gauge and it includes three lines and fuel feed line, fuel return line.

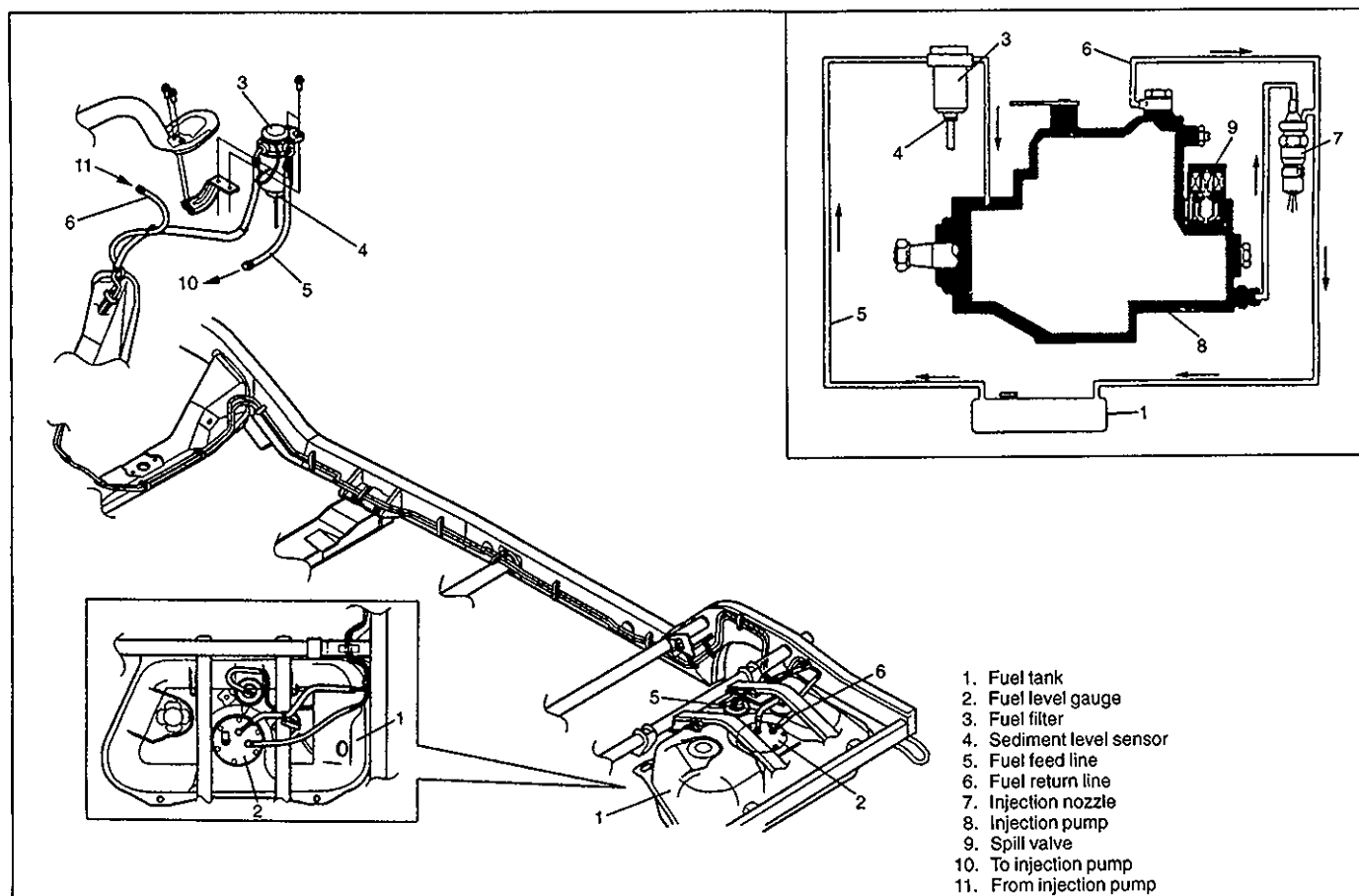

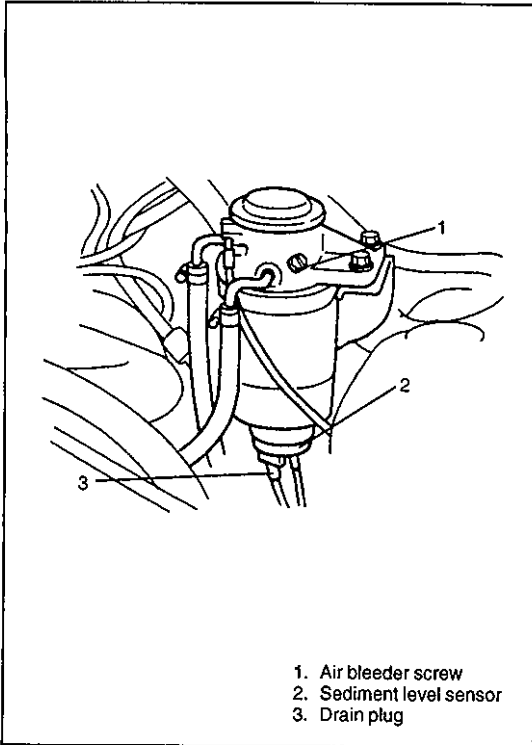

## ON-VEHICLE SERVICE

### WATER DRAINING OF FUEL SYSTEM

When sediment warning lamp is illuminated, drain water from fuel filter in following procedure.

- 1) Loosen drain plug at bottom of fuel filter.
- 2) Loosen air bleeder screw.
- 3) Drain water and tighten drain plug.
- 4) Tighten air bleeder screw.

### AIR BLEEDING OF FUEL SYSTEM

Air bleeding must be carried out when fuel system has been disassembled or when vehicle ran out of fuel.

#### CAUTION:

Continuously cranking engine for over 30 seconds can damage battery and the starting motor.

- 1) Repeat cranking engine for 30 seconds and stop for 5 – 10 seconds until engine starts.

### REPLACEMENT OF FUEL FILTER CARTRIDGE

#### REMOVAL

- 1) Disconnect battery.
- 2) Disconnect sediment level sensor connector.
- 3) Loosen drain plug at the bottom of fuel filter and drain fuel.
- 4) Remove sensor body.
- 5) Using a filter wrench, remove filter cartridge.

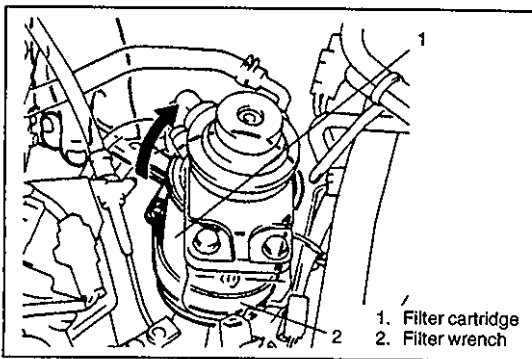

#### INSTALLATION

- 1) Apply small amount of fuel to new filter cartridge O ring.
- 2) Fully tighten filter cartridge by hand, not by filter wrench.
- 3) Install new O ring and fully tighten sensor body by hand.
- 4) Connect sediment level sensor connector.
- 5) After installation, bleed air in fuel line (Refer to "Air Bleeding of Fuel System" earlier in this section.) and verify that there is no fuel leakage.

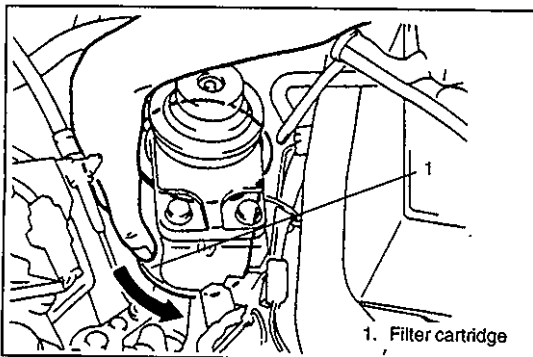

## INJECTION PUMP

For removal and installation, refer to "Injection Pump" in Section 6E3.

## FUEL FILTER

### FUEL FILTER CARTRIDGE REPLACEMENT

Refer to "Replacement of Fuel Filter Cartridge" earlier in this section.

### SEDIMENT LEVEL SENSOR

#### REMOVAL

Fix fuel filter body in a vise and remove level sensor from filter cartridge by using water pump pliers.

#### WARNING:

A small amount of fuel may be released from filter cartridge when sediment level sensor is removed. In order to reduce the chance of personal injury, cover the fitting to be disconnected with a shop cloth. Be sure to put that cloth in an approved container when removal is completed.

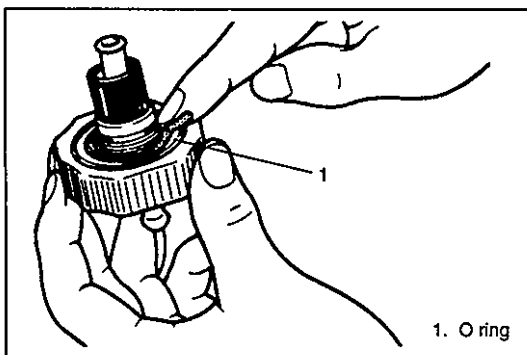
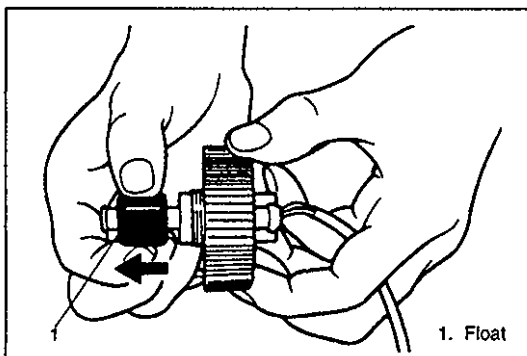
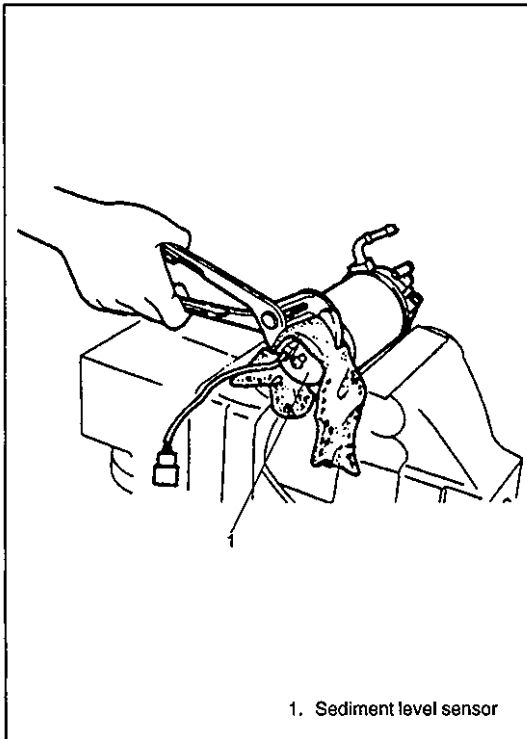

#### INSPECTION

- 1) Connect circuit tester to sediment level sensor connector.
- 2) Raise float and verify that there is continuity.

#### INSTALLATION

- 1) Use new sediment level sensor O ring.
- 2) Apply thin coat of fuel to O ring. Install the sediment level sensor to filter cartridge and fully tighten by hand.
- 3) Bleed air in system. (Refer to "Air Bleeding of Fuel System" earlier in this section.)
- 4) Verify that there is no leakage from fuel system.

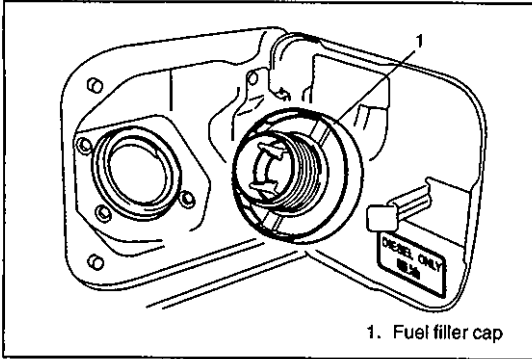

1. Fuel filler cap

## FUEL FILLER CAP

Remove cap, and check gasket for even filler neck imprint, and deterioration or any damage.

If gasket is in malcondition, replace cap.

### NOTE:

If cap requires replacement, only a cap with the same features should be used. Failure to use correct cap can result in serious malfunction of the system.

## 2-WAY CHECK VALVE

### INSPECTION

- 1) Air should pass through valve smoothly from fuel tank side (Black side of tank pressure control valve) to Orange side when blown hard.
- 2) From Orange side, even when blown softly, air should come out of Black side.
- 3) If air doesn't pass through valve in step 1) or hard blow is required in step 2), replace 2-way check valve.

### WARNING:

**DO NOT SUCK** air through 2-way check valve.  
Fuel vapor inside the valve is harmful.

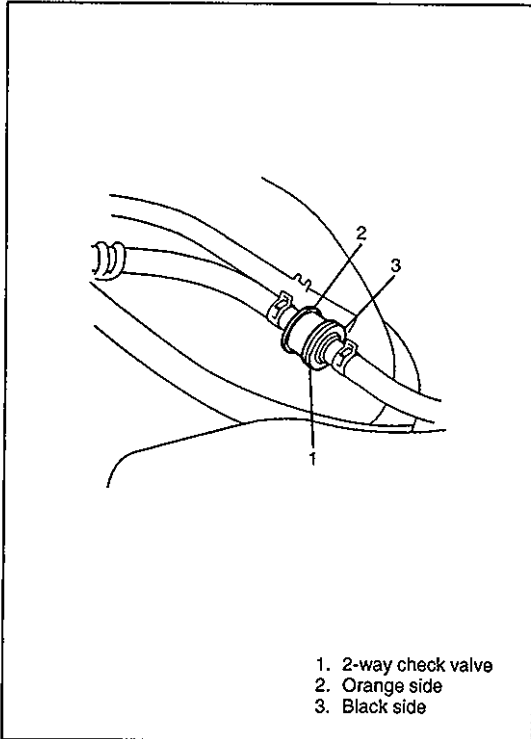

1. 2-way check valve  
2. Orange side  
3. Black side

## FUEL TANK

### REMOVAL

### CAUTION:

This work must not be done when engine is hot. If done so, it may cause adverse effect to catalyst.

- 1) Disconnect negative cable at battery.
- 2) Remove fuel filter cap.
- 3) Insert hose of a hand operated pump into fuel filler hose and drain fuel in space "A" in the figure (drain fuel through it till fuel stops).

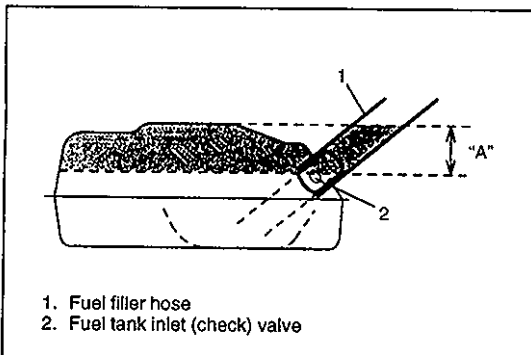

1. Fuel filler hose  
2. Fuel tank inlet (check) valve

### CAUTION:

**Do not force** hose of a hand operated pump into fuel tank.  
Doing so can damage inlet valve.

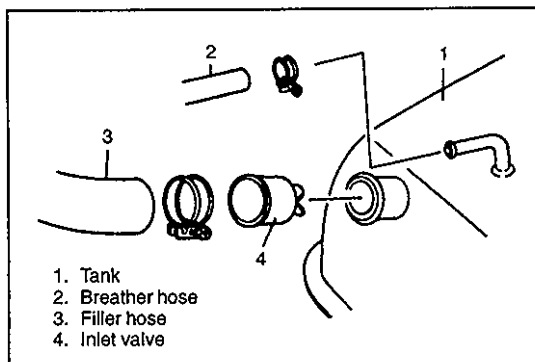

- 4) Remove fuel tank filler hose protector.  
Disconnect filler hose from fuel tank and breather hose from fuel filler neck.
- 5) Remove fuel tank inlet valve.  
Use care not to damage inlet valve when removing.

- 6) Drain fuel tank by pumping fuel out through fuel tank filler.  
Use hand operated pump device to drain fuel tank.

**CAUTION:**

**Never drain or store fuel in an open container due to possibility of fire or explosion.**

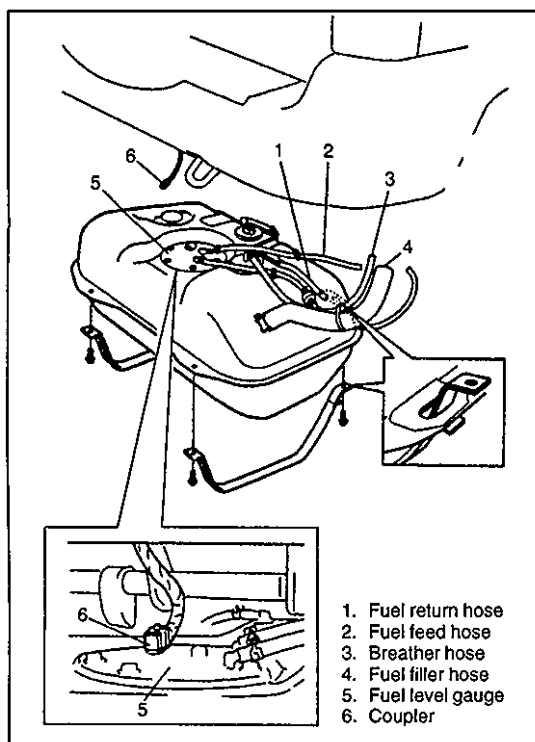

- 7) Disconnect fuel feed hose and fuel return hose from pipes.
- 8) Remove fuel tank protector (if equipped) from vehicle.
- 9) Lower fuel tank gradually while holding it horizontally and pull out coupler at fuel level gauge.

**INSTALLATION**

For installation, reverse removal procedure described above.

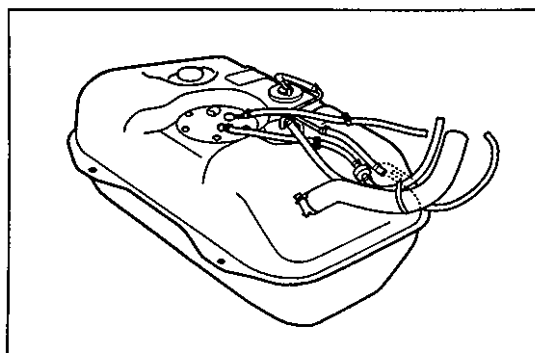

**INSPECTION**

After removing fuel tank, check hoses and pipes connected to fuel tank for leaks, loose connections, deterioration or damage. Also check fuel level gauge gaskets for leaks, visually inspect fuel tank for leaks and damage.

Replace any damaged or malconditioned parts.

**TIGHTENING TORQUE SPECIFICATION**

Fastening parts	Tightening torque		
	N·m	kg-m	lb-ft
Fuel level gauge bolt	5	0.5	3.5

## SECTION 6E3

# ENGINE AND EMISSION CONTROL SYSTEM (RF ENGINE)

**WARNING:**

For vehicles equipped with Supplemental Restraint (Air Bag) System:

- Service on and around the air bag system components or wiring must be performed only by an authorized SUZUKI dealer. Refer to "Air Bag System Components and Wiring Location View" under "General Description" in air bag system section in order to confirm whether you are performing service on or near the air bag system components or wiring. Please observe all WARNINGS and "Service Precautions" under "On-Vehicle Service" in air bag system section before performing service on or around the air bag system components or wiring. Failure to follow WARNINGS could result in unintentional activation of the system or could render the system inoperative. Either of these two conditions may result in severe injury.
- Technical service work must be started at least 90 seconds after the ignition switch is turned to the "LOCK" position and the negative cable is disconnected from the battery. Otherwise, the system may be activated by reserve energy in the Sensing and Diagnostic Module (SDM).

## CONTENTS

<b>GENERAL DESCRIPTION</b> .....	6E3- 3	<b>ON-VEHICLE SERVICE</b> .....	6E3-20
System Diagram .....	6E3- 3	General .....	6E3-20
Air Intake System .....	6E3- 4	Accelerator Cable and A/T Throttle Cable Adjustment .....	6E3-20
Fuel Delivery System .....	6E3- 5	Idle Speed Adjustment .....	6E3-20
Electronic Control System .....	6E3- 6	Injection Timing Adjustment .....	6E3-21
System location diagram .....	6E3- 7	Diesel Smoke Inspection .....	6E3-21
System wiring diagram .....	6E3- 8	<b>AIR INTAKE SYSTEM</b> .....	6E3-22
Quick Start System Control .....	6E3-10	Vacuum hose routing diagram .....	6E3-22
A/C Cut Control (If equipped) .....	6E3-10	Air intake system parts removal and installation .....	6E3-23
Immobilizer Control (If equipped) .....	6E3-10	Intake shutter solenoid valve .....	6E3-24
<b>DIAGNOSIS</b> .....	6E3-11	Intake shutter valve actuator .....	6E3-24
Precautions in Diagnosing Troubles ....	6E3-11	Turbocharger .....	6E3-25
Basic Check .....	6E3-12	Wastegate valve .....	6E3-25
Diagnostic Trouble Code Check .....	6E3-13	<b>QUICK START SYSTEM CONTROL</b> ....	6E3-26
Diagnostic Trouble Code Clearance ....	6E3-13	System inspection .....	6E3-26
Diagnostic Trouble Code Table .....	6E3-14		
Inspection of ECM and Its Circuits ....	6E3-15		

Glow plug .....	6E3-27	Timer control valve .....	6E3-40
Glow plug relay .....	6E3-27	Fuel temperature sensor .....	6E3-40
<b>FUEL DELIVERY SYSTEM</b> .....	<b>6E3-28</b>	ECT sensor .....	6E3-41
Precautions .....	6E3-28	Compensation resistance .....	6E3-41
Injection Nozzle .....	6E3-28	CKP sensor .....	6E3-42
Injection Pump .....	6E3-32	<b>EGR SYSTEM</b> .....	<b>6E3-43</b>
<b>ELECTRONIC CONTROL SYSTEM</b> ..	<b>6E3-34</b>	On-vehicle inspection .....	6E3-43
Engine control module(ECM) .....	6E3-34	Vacuum hose .....	6E3-43
Boost sensor .....	6E3-35	EGR valve .....	6E3-44
TP sensor .....	6E3-35	EGR position sensor .....	6E3-44
Closed throttle position switch .....	6E3-36	EGR solenoid vacuum valve .....	6E3-44
NE sensor .....	6E3-37	EGR solenoid vent valve .....	6E3-45
VSS .....	6E3-37	<b>TIGHTENING TORQUE</b>	
IAT sensor .....	6E3-38	<b>SPECIFICATIONS</b> .....	6E3-46
Spill valve .....	6E3-39	<b>SPECIAL TOOLS</b> .....	6E3-46
Spill valve relay .....	6E3-39		

## GENERAL DESCRIPTION

## SYSTEM DIAGRAM

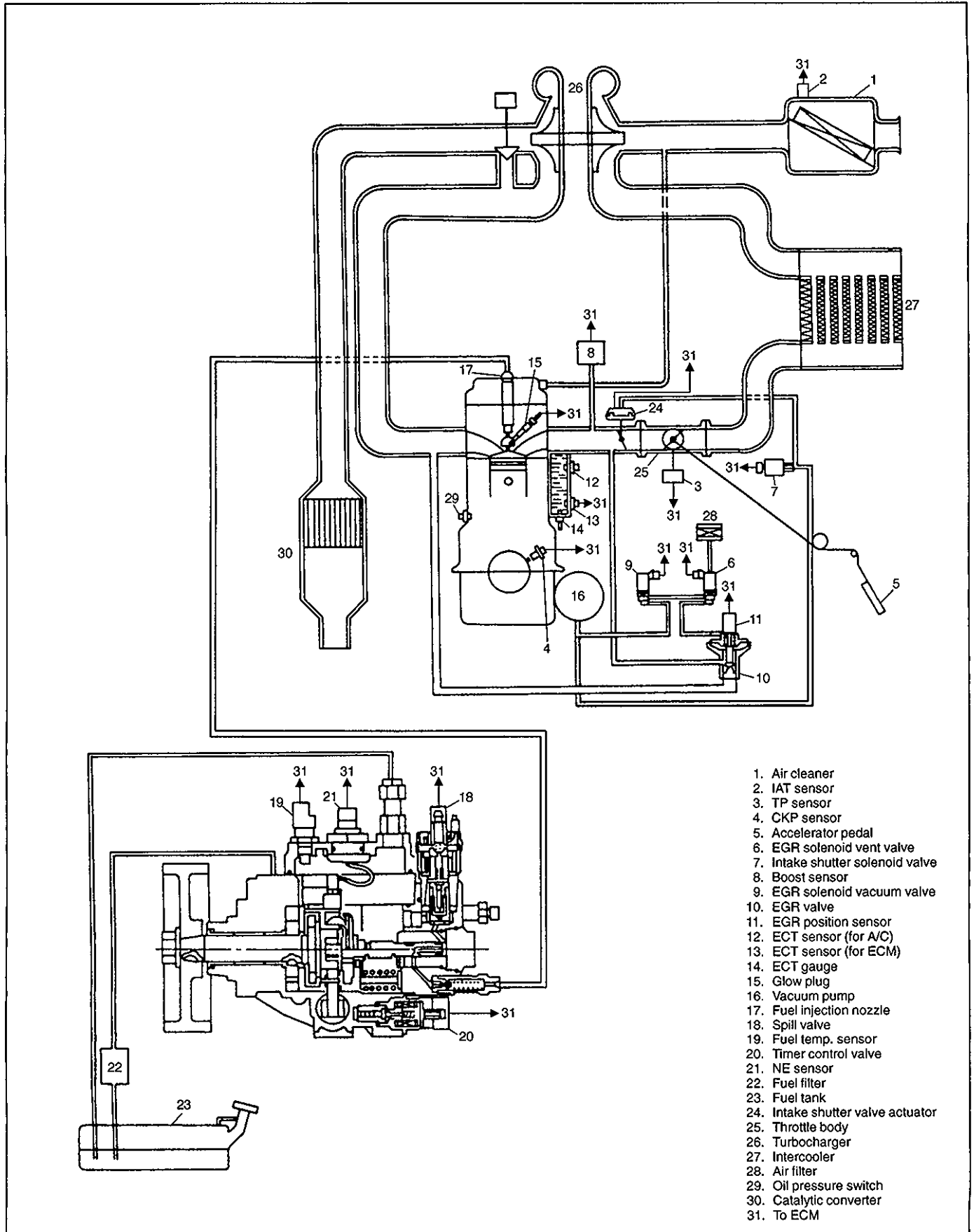

## AIR INTAKE SYSTEM

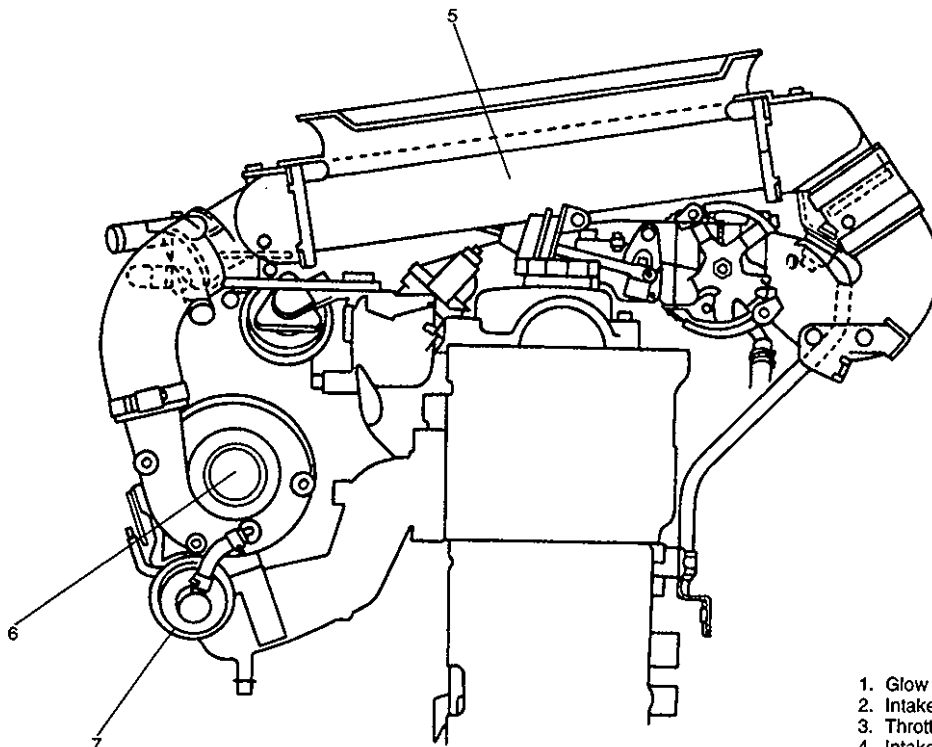
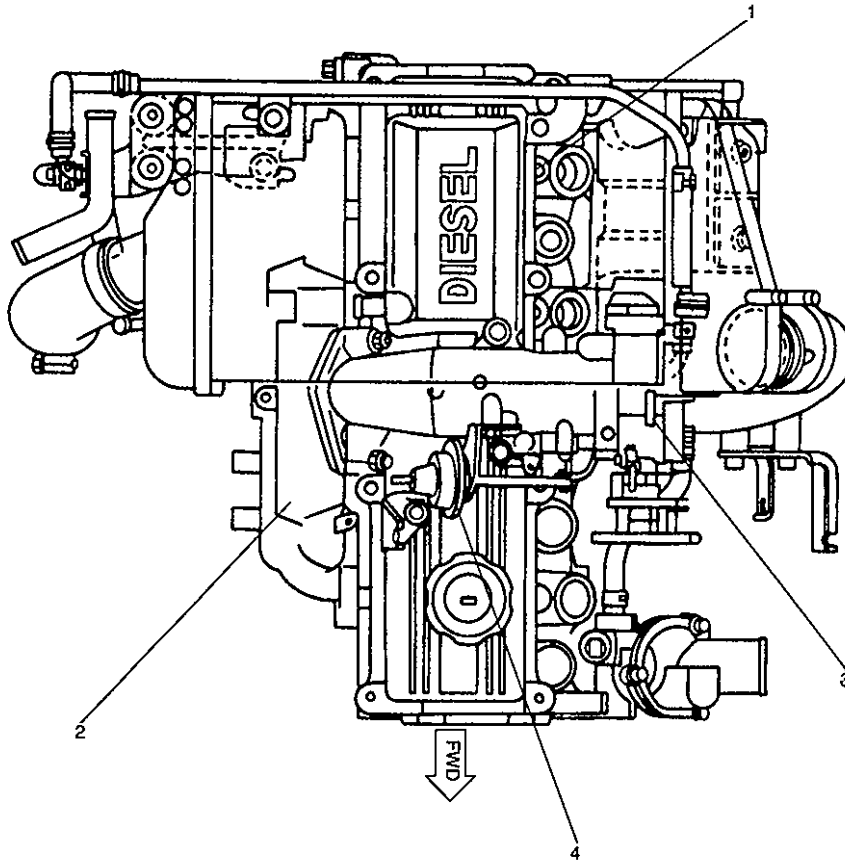

1. Glow plug
2. Intake manifold
3. Throttle body
4. Intake shutter valve actuator
5. Intercooler
6. Turbocharger
7. Wastegate valve

# FUEL DELIVERY SYSTEM

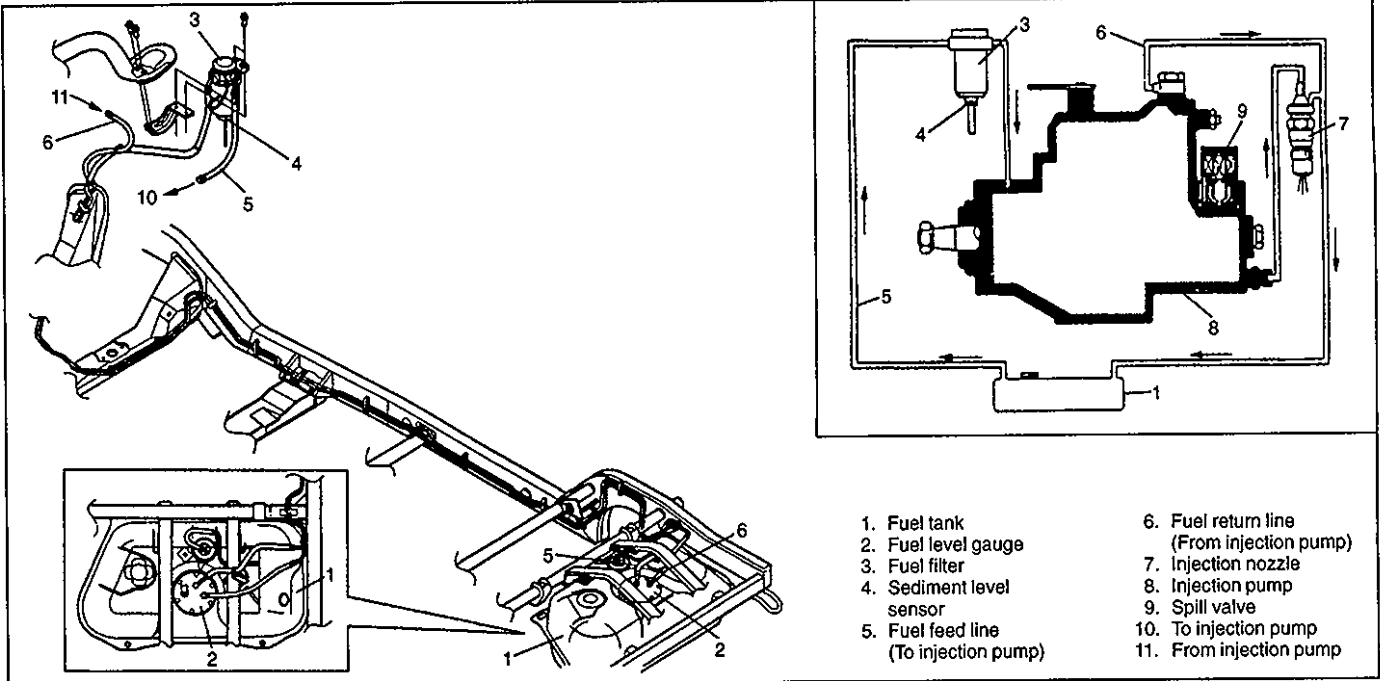

- 1. Fuel tank
- 2. Fuel level gauge
- 3. Fuel filter
- 4. Sediment level sensor
- 5. Fuel feed line (To injection pump)
- 6. Fuel return line (From injection pump)
- 7. Injection nozzle
- 8. Injection pump
- 9. Spill valve
- 10. To injection pump
- 11. From injection pump

## FUEL INJECTION PUMP

The fuel injection pump is of a distribution type. The fuel injection pump controls the fuel injection volume via the electromagnetic valve, and directly spills the pressurized fuel.

The fuel injection pump is equipped with the following control units.

- |                               |   |
|-------------------------------|---|
| Fuel injection volume control | <ul style="list-style-type: none"> <li>Actuator . . . . NE spill valve</li> <li>Sensor . . . . Fuel temp. sensor</li> <li>Adjustment . Compensation resistance (<math>\theta</math>)</li> </ul> |
| Fuel injection timing control | <ul style="list-style-type: none"> <li>Actuator . . . . Timing control valve</li> <li>Sensor . . . . NE sensor</li> <li>Adjustment . Compensation resistance (<math>\gamma</math>)</li> </ul>   |
| Fuel cut control              | <ul style="list-style-type: none"> <li>Actuator . . . . Spill valve</li> </ul>  |

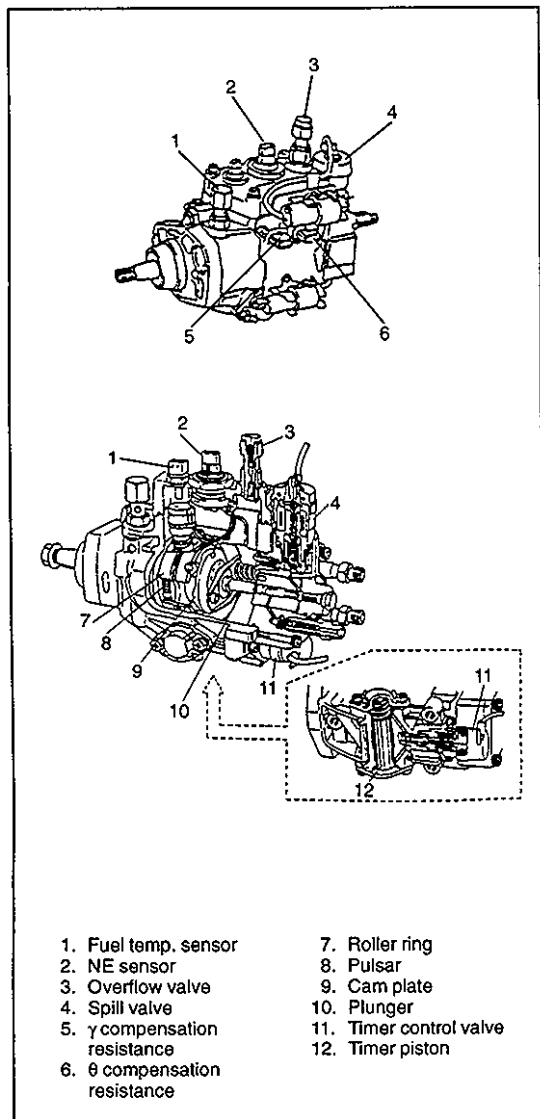

- 1. Fuel temp. sensor
- 2. NE sensor
- 3. Overflow valve
- 4. Spill valve
- 5.  $\gamma$  compensation resistance
- 6.  $\theta$  compensation resistance
- 7. Roller ring
- 8. Pulsar
- 9. Cam plate
- 10. Plunger
- 11. Timer control valve
- 12. Timer piston

## ELECTRONIC CONTROL SYSTEM

The electronic control system carries out various controls such as the fuel injection volume, fuel injection timing, idle speed, EGR and quick start system via the ECM. This system is equipped with the self-diagnosis function which detects abnormal condition in the ECM input/output signals. The system also has the fail-safe function.

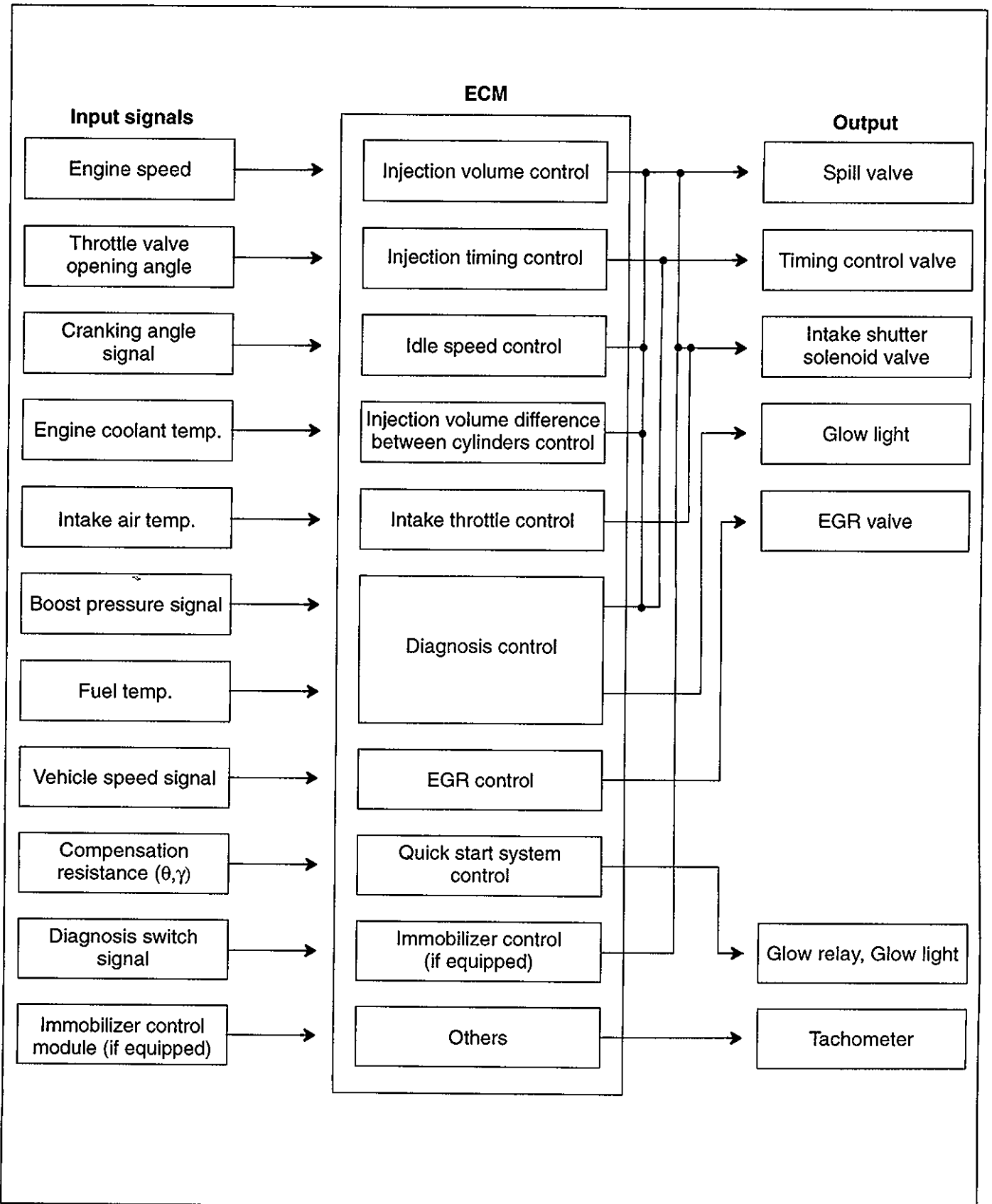

SYSTEM LOCATION DIAGRAM

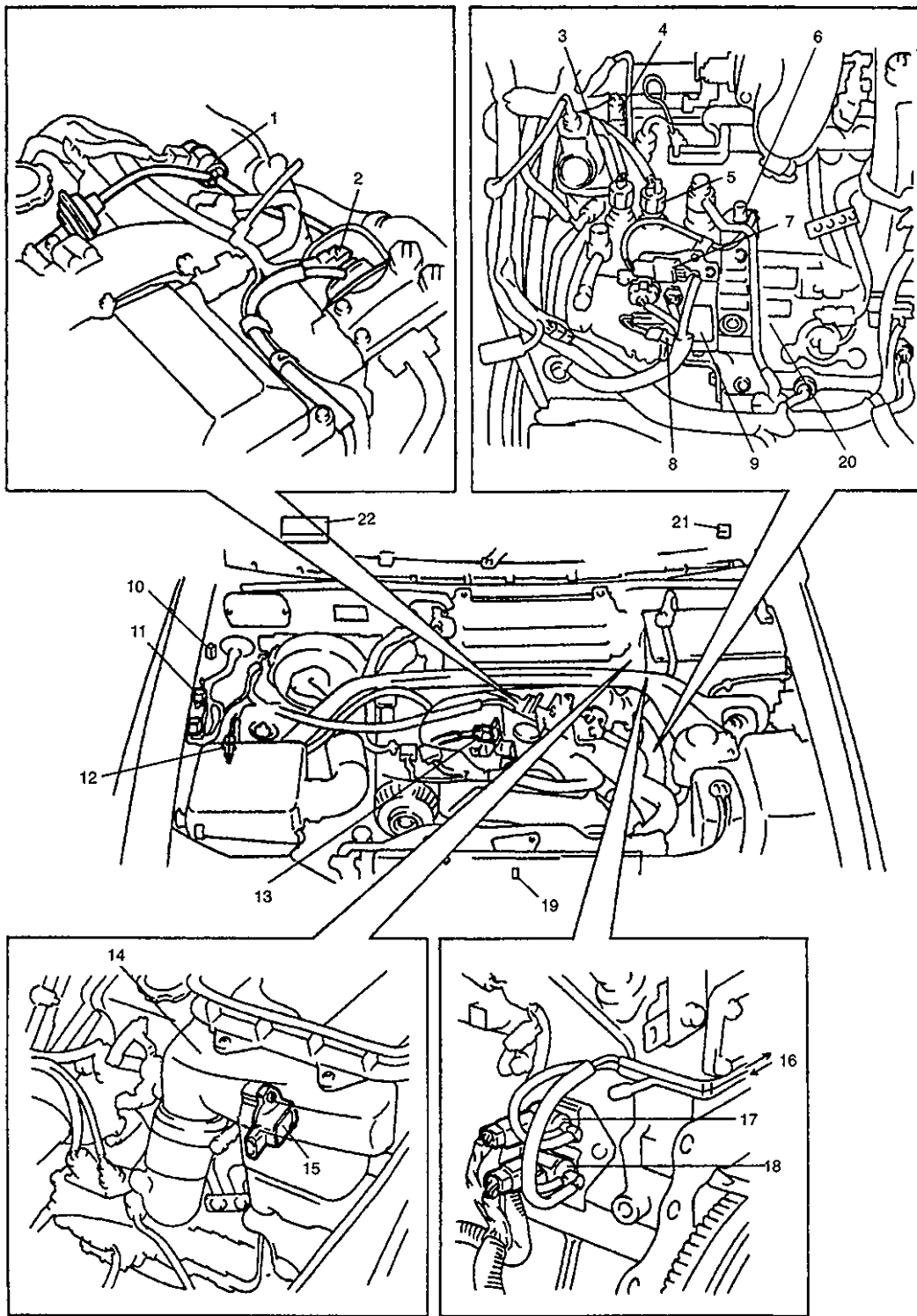

- |  |                               |
|--|-------------------------------|
| 1. Intake shutter solenoid valve             | 12. IAT sensor                |
| 2. EGR position sensor                       | 13. Boost sensor              |
| 3. Fuel temp. sensor                         | 14. Intercooler               |
| 4. ECT sensor                                | 15. TP sensor                 |
| 5. NE sensor                                 | 16. To EGR vacuum pump        |
| 6. Spill valve                               | 17. EGR solenoid vacuum valve |
| 7. Spill valve connector                     | 18. EGR solenoid vent valve   |
| 8. Timer control valve connector             | 19. CKP sensor                |
| 9. Timer control valve                       | 20. Fuel injection pump       |
| 10. Glow relay                               | 21. Spill valve relay         |
| 11. Monitor coupler (white coupler, for ECM) | 22. ECM                       |

SYSTEM WIRING DIAGRAM

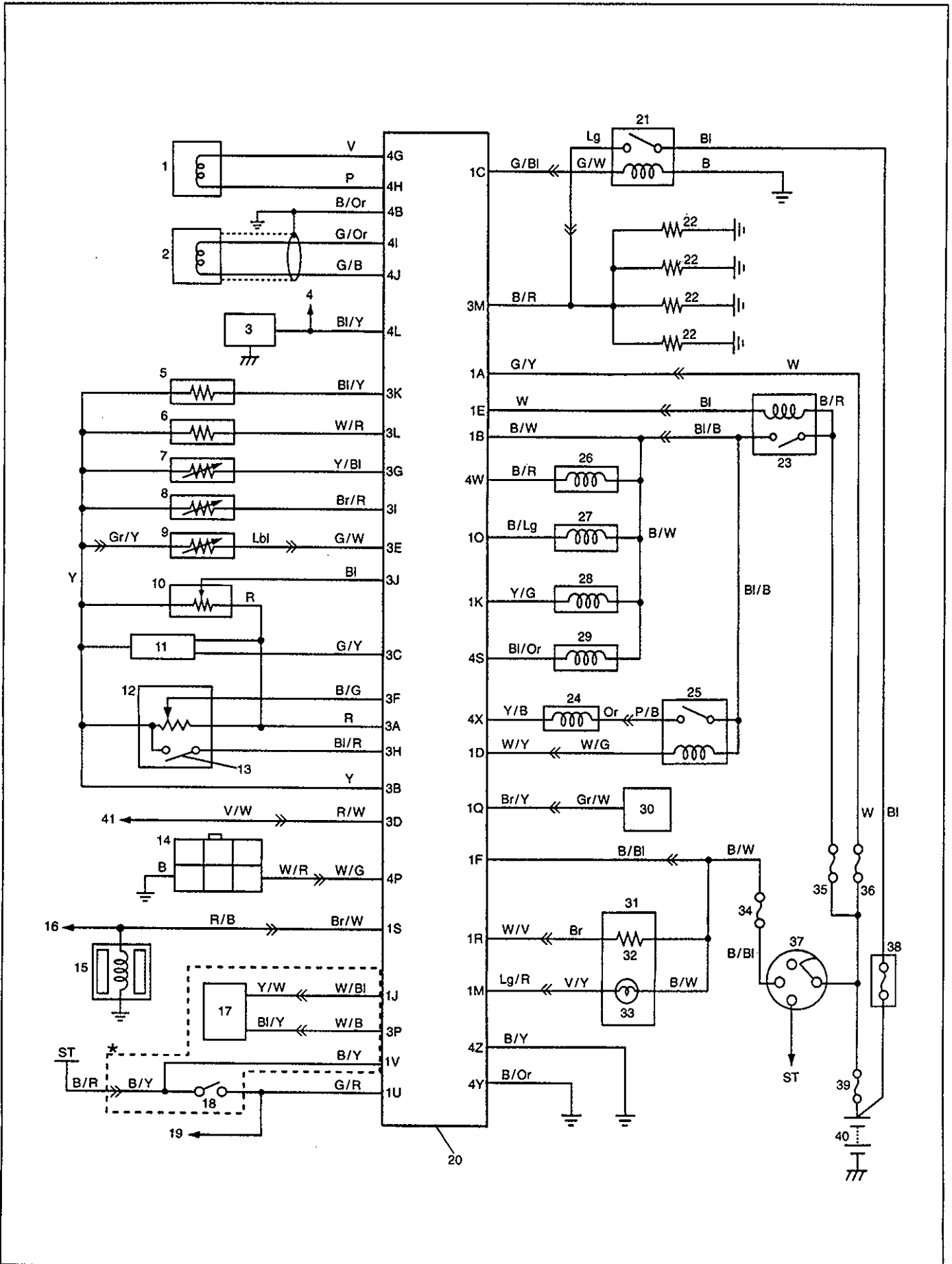

## ECM CONNECTOR (TERMINAL ARRANGEMENT VIEWED FROM HARNESS SIDE)

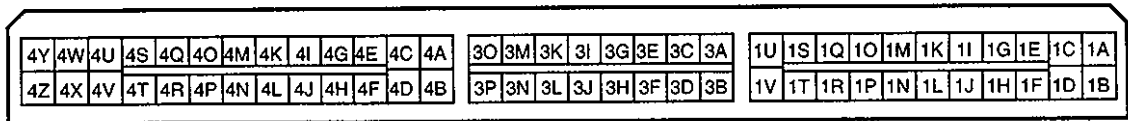

- |                                     |   |   |
|-------------------------------------|---|---|
| 1. NE sensor                        | 16. To A/C switch (if equipped)         | 31. Combination meter                           |
| 2. CKP sensor                       | 17. TCM (For A/T)                       | 32. Tachometer                                  |
| 3. VSS                              | 18. Transmission range switch (For A/T) | 33. Glow light                                  |
| 4. To combination meter             | 19. To starting motor                   | 34. "IG METER" fuse (20 A)                      |
| 5. $\theta$ compensation resistor   | 20. ECM                                 | 35. "ENGINE" fuse (15 A)                        |
| 6. $\gamma$ compensation resistor   | 21. Glow relay                          | 36. "DOME" fuse (15 A)                          |
| 7. ECT sensor                       | 22. Glow plug                           | 37. Ignition switch                             |
| 8. Fuel temp. sensor                | 23. Main relay                          | 38. Fusible link                                |
| 9. IAT sensor                       | 24. Spill valve solenoid                | 39. Fuse (80 A) in main fuse box                |
| 10. EGR position sensor             | 25. Spill valve relay                   | 40. Battery                                     |
| 11. Boost sensor                    | 26. Timer control solenoid valve        | 41. To Immobilizer control module (if equipped) |
| 12. TP sensor                       | 27. EGR solenoid vent valve             |   |
| 13. Closed throttle position switch | 28. EGR solenoid vacuum valve           |   |
| 14. Monitor coupler (white coupler) | 29. Intake shutter solenoid valve       |   |
| 15. A/C compressor (if equipped)    | 30. A/C controller (if equipped)        |   |

Terminal	Wiring color	Connect to	Terminal	Wiring color	Connect to	Terminal	Wiring color	Connect to
1A	G/Y	Power circuit	3A	R	Power to TP sensor	4A	--	Blank
1B	B/W	Main relay	3B	Y	Sensor ground	4B	B/Or	Ground
1C	G/Bl	Glow plug relay	3C	G/Y	Boost sensor	4C	--	Blank
1D	W/Y	Spill valve relay	3D	R/W	Immobilizer control module (if equipped)	4D	--	Blank
1E	W	Main relay				4E	--	Blank
1F	B/Bl	Ignition switch	3E	G/W	IAT sensor	4F	--	Blank
1G	--	Blank	3F	B/G	TP sensor	4G	V	NE sensor (+)
1H	--	Blank	3G	Y/Bl	ECT sensor	4H	P	NE sensor (-)
1I	--	Blank	3H	Bl/R	Closed throttle position switch	4I	G/Or	CKP sensor (+)
1J	W/Bl	TCM				4J	G/B	CKP sensor (-)
1K	Y/G	EGR solenoid vacuum valve	3I	Br/R	Fuel temp. sensor	4K	--	Blank
1L	--	Blank	3J	Bl	EGR position sensor	4L	Bl/Y	VSS
1M	Lg/R	Glow light	3K	Bl/Y	$\theta$ compensation resistor	4M	--	Blank
1N	--	Blank	3L	W/R	$\gamma$ compensation resistor	4N	--	Blank
1O	B/Lg	EGR solenoid vent valve	3M	B/R	Glow plug relay	4O	--	Blank
1P	--	Blank	3N	--	Blank	4P	W/G	Diagnosis switch
1Q	Br/Y	A/C amplifier	3O	--	Blank	4Q	--	Blank
1R	W/V	Tachometer in combination meter	3P	W/B	TCM (for A/T)	4R	--	Blank
1S	Br/W	A/C compressor (if equipped)				4S	Bl/Or	Intake shutter valve solenoid
1T	--	Blank				4T	--	Blank
1U	G/R	Starting motor				4U	--	Blank
1V	B/Y	Transmission range switch (for A/T)				4V	--	Blank
						4W	B/R	Timer control valve solenoid
						4X	Y/B	Spill valve solenoid
						4Y	B/Or	Ground
						4Z	B/Y	Ground

## QUICK START SYSTEM CONTROL

The quick start system control controls the glow plug relay.

The glow plug relay is energized while the glow light is illuminated, during quick glow control, long glow continuation control, and while the engine is cranking.

### GLOW LIGHT CONTROL

The glow light is illuminated for several seconds after the ignition switch is turned to ON position to indicate that the quick start system is operated and the engine can be started.

Illumination duration of the indicator light varies with the engine coolant temperature. (Refer to the table below.)

While the glow light is illuminated, the glow plug relay also is energized.

Engine coolant temperature °C (°F)	Glow light illumination duration (sec.)
60 (140)	1.6
40 (104)	1.8
20 (68)	2.6
0 (32)	3.8
-20 (-68)	5.6
-40 (-104)	7.4

### QUICK GLOW CONTROL

To maintain engine startability during the engine is cold (engine coolant temperature below 60°C (140°F)), the glow relay will be energized for approx. 15 seconds when the ignition switch is left in ON position after the glow light went out.

When the engine coolant temperature is over 60°C (140°F), the glow relay will be energized during cranking the engine.

### LONG GLOW CONTINUATION CONTROL

In the long glow continuation control, the glow plug will be energized for 10 minutes after cranking (just after engine start). The control will be inhibited when any of the following conditions is met:

- Engine coolant temperature is over 60°C (140°F).
- Battery positive voltage exceeded 15 V.
- Throttle valve opening angle exceeded a certain value or engine speed exceeded 2,000 rpm for over 30 seconds.
- NE sensor, ECT sensor, glow relay or TP sensor has failed.

### A/C CUT CONTROL (IF EQUIPPED)

The A/C cut control is carried out to maintain drivability of the vehicle when the engine is hot. The A/C relay is shut off for 4 seconds when any of the following conditions is met:

- Gear position is in other than Neutral for M/T (P range for A/T) and throttle valve opening angle is over 20 %.
- After the condition above was met. A/C cut control is inhibited until the following conditions is met:

- Vehicle speed is 0 km/h.
- Ignition switch OFF.

### IMMOBILIZER CONTROL (IF EQUIPPED)

When the immobilizer control system is actuated, the following controls will also be carried out. Refer to SECTION 8G for the details.

Spill valve : OFF

Spill valve relay : OFF

Intake shutter valve : Fully closed

## DIAGNOSIS

The ECM has two diagnosis functions; the self-diagnosis function for the engine and emission systems, and the fail-safe function. Refer to SECTION 8G for the self-diagnosis function for immobilizer control system, which is for the immobilizer control system-equipped vehicles only.

### SELF-DIAGNOSIS FUNCTION (ON-BOARD DIAGNOSTIC SYSTEM)

Trouble detection of the input systems is carried out while the ignition switch is ON (include while the engine is running).

When a problem is detected, the glow light flashes or illuminates while the ignition switch is ON (include while the engine is running) to indicate the presence of the problem.

### FAIL-SAFE FUNCTION

When an input sensor has failed, the fail-safe function switches the input signal value of the failed sensor to the preset value in the ECM memory, so that the vehicle's drivability is maintained.

## PRECAUTIONS IN DIAGNOSING TROUBLES

- Before identifying diagnostic trouble code indicated by malfunction indicator lamp (glow light), don't disconnect couplers from ECM, battery cable from battery, ECM ground wire harness from engine or main fuse. Such disconnection will erase memorized trouble in ECM memory.
- Because ECM stores diagnostic trouble codes in its memory, codes can be displayed even after detected problems have been repaired. Erase codes and perform confirmation test after repairs have been completed.
- As for vehicles equipped with immobilizer control system, if glow light flashes when ignition switch is turned to ON (engine not started), follow procedures in "Diagnostic Flow Table" in SECTION 8G.

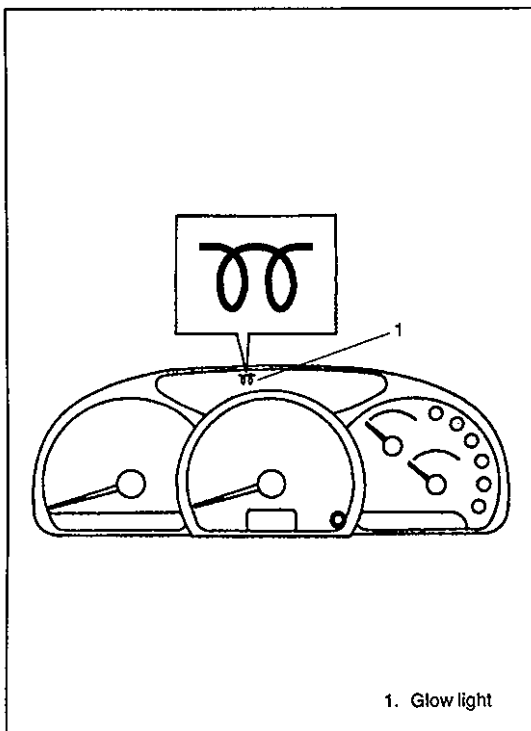

## BASIC CHECK

### NOTE:

When removing fuel injection pipe, cover pipe with rug for protection against fuel leakage.

Step	Inspection		Action
1	Does glow light turn ON for several seconds and then go out when ignition switch is turned to ON (Engine not running)?	Yes	Go to step 4.
		No (Flashes)	Go to "Diagnostic Flow Chart" in SECTION 8G.
		No (Remains ON)	Go to step 2.
		No (Not illuminate)	Check followings. <ul style="list-style-type: none"> <li>• Main fuse/circuit fuse</li> <li>• Main relay and related circuit</li> <li>• Connection of ECM coupler and terminal</li> <li>• ECM ground circuit</li> <li>• Glow light bulb and related circuit</li> <li>• ECM</li> </ul>
2	Connect terminals "A" (for diagnosis switch circuit) and "C" (for ground circuit) on monitor coupler with service wire, and check glow light.	Remains ON	Check followings. <ul style="list-style-type: none"> <li>• Glow light bulb and related circuit</li> <li>• Service wire continuity</li> <li>• Monitor coupler circuit</li> <li>• ECM</li> </ul>
		Flashes	Go to step 3.
3	1) Go to appropriate inspection point in Diagnostic Trouble Code Table according to code No. 2) After repairs, erase diagnostic trouble code. 3) Start engine and warm it up to normal operating temperature. 4) Connect terminals "A" and "C" on monitor coupler with service wire, and check glow light. Is Code No.12 indicated only?	Yes	If any problem is detected, go to step 4.
		No	Repeat step 3.
4	Loosen fuel injection nozzle side flare nut at each cylinder one by one in order and crank the engine. Is fuel injected intermittently at each cylinder?	Yes	Go to step 5.
		No	Check fuel injection pipe for clogs. If fuel injection pipe is OK, replace fuel injection pump
5	While idling engine, slowly loosen/tighten fuel injection nozzle side flare nut at each cylinder one by one in order, and check for change in engine speed and vibration. Does Idle speed drop and engine vibration change equally at all cylinders?  <b>NOTE:</b> <ul style="list-style-type: none"> <li>• If idle speed will not drop or drops less at one cylinder, distribution at cylinder is weak.</li> <li>• If idle speed stabilizes when a small amount of fuel is released through flare nut, distribution at cylinder is strong.</li> </ul>	Yes	Go to step 6.
		No	Perform "Compression Inspection". (Refer to Section 6A3.)
6	Does smoke emitted only when engine is started?	Yes	Perform "System Inspection" under "Quick Start System Control" in this section.
		No	Go to step 7.
7	Inspect fuel injection nozzle. (Refer to "Injection Nozzle" under "Fuel Delivery System" in this section.) Is it normal?	Yes	Go to "Engine Diagnosis Table" in SECTION 6.
		No	Repair or replace.

## DIAGNOSTIC TROUBLE CODE CHECK

Connect a service wire to terminals "A" and "C" on monitor coupler, and check flashing pattern of glow light.

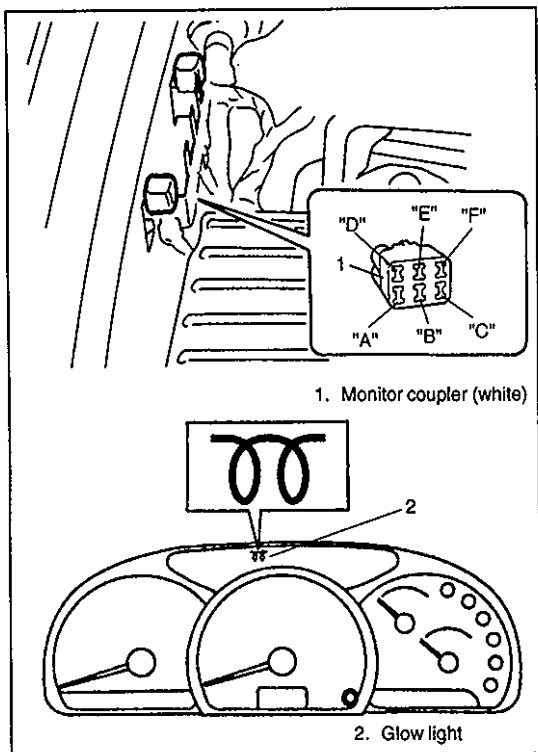

Diagnostic trouble code output example

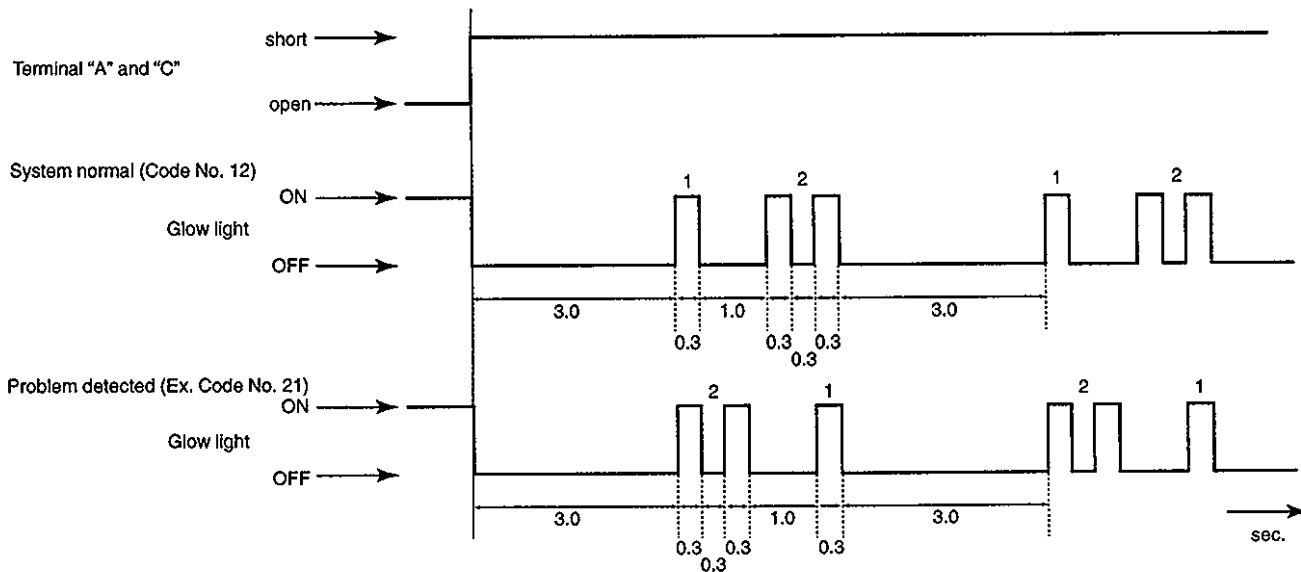

## DIAGNOSTIC TROUBLE CODE CLEARANCE

To erase diagnostic trouble codes stored in ECM memory, disconnect battery cable for more than 30 seconds.

## DIAGNOSTIC TROUBLE CODE TABLE

Code No.	Diagnosed system	Detection condition	Fail safe	Inspection point
12	Normal	—	—	—
14	ECT sensor signal	<ul style="list-style-type: none"> <li>• Short circuit</li> <li>• High signal voltage</li> </ul>	Set engine coolant temp. to appropriate temp., and perform each control.	<ul style="list-style-type: none"> <li>• ECT sensor</li> <li>• Related wiring harness</li> </ul>
15		<ul style="list-style-type: none"> <li>• Open circuit</li> <li>• Low signal voltage</li> </ul>		
21	TP sensor signal	• High signal voltage	Set throttle valve opening to 0% when accelerator pedal is not depressed, and to 15% when accelerator pedal is depressed, and perform each control.	<ul style="list-style-type: none"> <li>• TP sensor</li> <li>• Related wiring harness</li> </ul>
22		• Low signal voltage		<ul style="list-style-type: none"> <li>• TP sensor</li> <li>• Related wiring harness</li> </ul>
23	IAT sensor signal	<ul style="list-style-type: none"> <li>• Short circuit</li> <li>• High signal voltage</li> </ul>	Set intake air temp. to appropriate temp., and perform each control.	<ul style="list-style-type: none"> <li>• IAT sensor</li> <li>• Related wiring harness</li> </ul>
25		<ul style="list-style-type: none"> <li>• Open circuit</li> <li>• Low signal voltage</li> </ul>		
24	VSS signal	• No VSS signal input	Detect vehicle speed as 0 km/h (0 mph), and perform each control.	<ul style="list-style-type: none"> <li>• VSS</li> <li>• Related wiring harnesses</li> </ul>
27	Compensation resistance signal ( $\theta, \gamma$ compensation)	• Open or shorted	<ul style="list-style-type: none"> <li>• Set <math>\theta</math> compensation resistance signal to specified value.</li> <li>• Set <math>\gamma</math> compensation resistance signal to specified value.</li> </ul>	<ul style="list-style-type: none"> <li>• Compensation resistance</li> <li>• Related wiring harness</li> </ul>
28	Glow plug relay signal	• Open or shorted	Detect glow plug relay is OFF.	<ul style="list-style-type: none"> <li>• Glow plug relay</li> <li>• Related wiring harness</li> </ul>
31	Boost sensor signal	• Low signal voltage	Set sensor signal to medium value.	<ul style="list-style-type: none"> <li>• Boost sensor</li> <li>• Related wiring harness</li> </ul>
32		• High signal voltage		
35	NE sensor signal	• No NE sensor signal input	<ul style="list-style-type: none"> <li>• Turn spill valve OFF.</li> <li>• Fix timer control valve duty value to specification.</li> </ul>	<ul style="list-style-type: none"> <li>• NE sensor</li> <li>• Related wiring harness</li> </ul>
41	Timer control valve signal	• Open or shorted	Reduce max. injection volume.	<ul style="list-style-type: none"> <li>• Timer control valve</li> <li>• Related wiring harness</li> </ul>
42	CKP sensor signal	<ul style="list-style-type: none"> <li>• Open or shorted</li> <li>• Faulty pulsar projection</li> </ul>	Fix timer control valve duty value to specification.	<ul style="list-style-type: none"> <li>• CKP sensor</li> <li>• Related wiring harness</li> </ul>
43	Starter signal	• Starter signal turns on while engine is running	Detects starter signal as OFF.	<ul style="list-style-type: none"> <li>• Starter</li> <li>• Related wiring harness</li> </ul>
		• Starter signal turns off while engine is cranking	Detects starter signal as ON.	
45	Closed throttle position switch signal	• Closed throttle position switch circuit shorted.	Detects throttle valve opening as 10%.	<ul style="list-style-type: none"> <li>• Closed throttle position sensor</li> <li>• Related wiring harness</li> </ul>
51	EGR position sensor signal	• Open or shorted	Inhibits EGR control.	<ul style="list-style-type: none"> <li>• EGR position sensor</li> <li>• Related wiring harness</li> </ul>
52	Spill valve signal	<ul style="list-style-type: none"> <li>• Open or shorted</li> <li>• Stuck spill valve</li> </ul>	<ul style="list-style-type: none"> <li>• Turns spill valve OFF.</li> <li>• Turns spill valve relay OFF.</li> <li>• Intake shutter valve actuator fully closed.</li> </ul>	<ul style="list-style-type: none"> <li>• Spill valve</li> <li>• Related wiring harness</li> </ul>
73	Fuel temp. sensor signal	• Open or shorted	Detects fuel temp. as appropriate temp..	<ul style="list-style-type: none"> <li>• Fuel temp. sensor</li> <li>• Related wiring harness</li> </ul>
81	Refer to SECTION 8G for information concerning code No. 81-84.	—	—	—
82				
83				
84				
Illumination	ECM	—	—	—

## INSPECTION OF ECM AND ITS CIRCUITS

ECM and its circuits can be checked at ECM wiring couplers by measuring voltage and resistance.

**CAUTION:**

**ECM cannot be checked by itself. It is strictly prohibited to connect voltmeter or ohmmeter to ECM with couplers disconnected from it.**

**VOLTAGE CHECK**

- 1) Remove ECM cover from bracket with ignition switch OFF, referring to ECM REMOVAL.
- 2) Check voltage at each terminal of couplers connected

**NOTE:**

**As each terminal voltage is affected by battery voltage, confirm that it is 11 V or more when ignition switch is ON.**

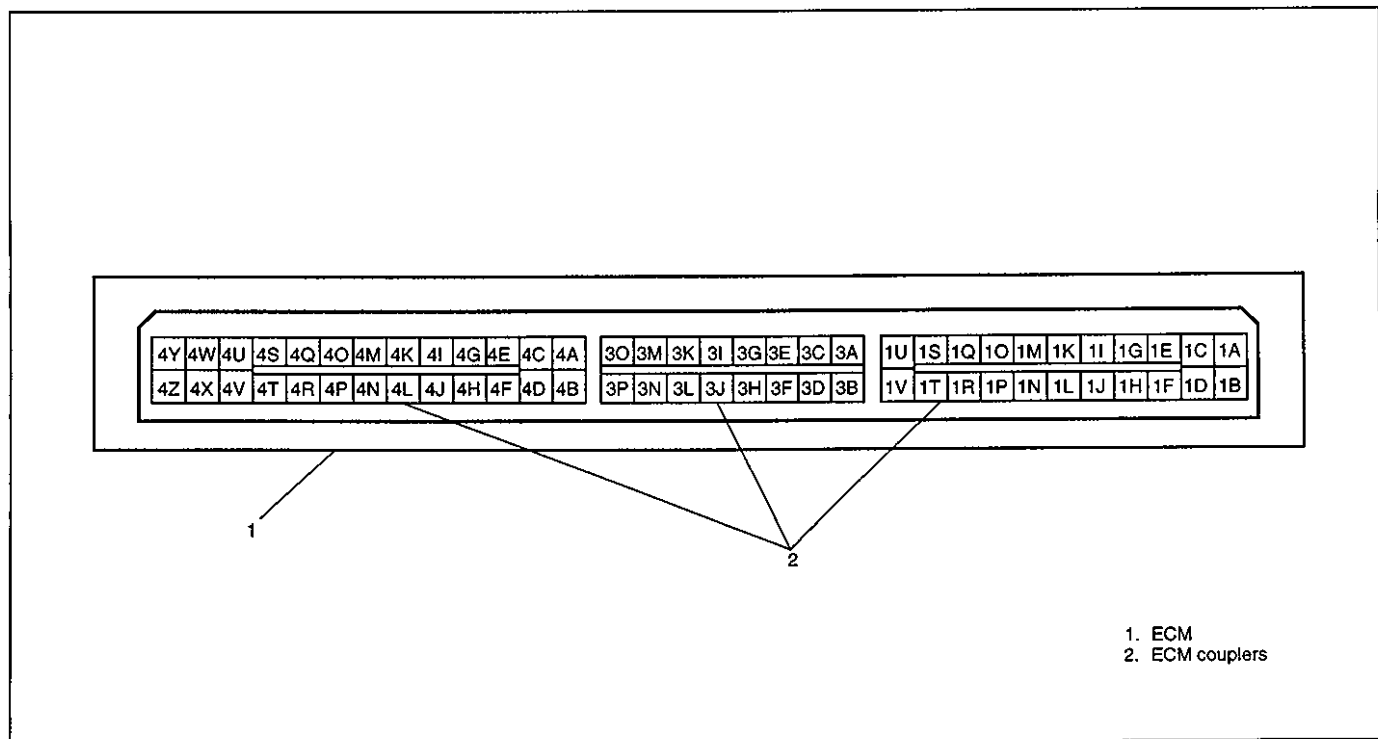
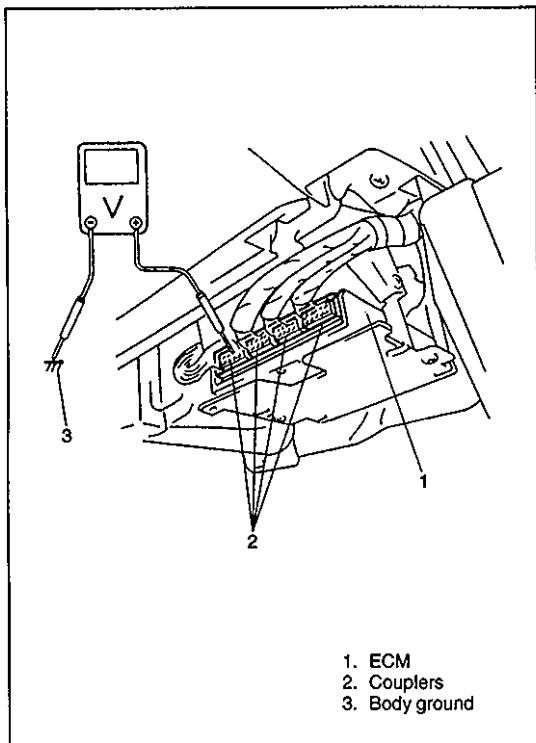

Terminal	Connected to	Measuring condition		Voltage (V)	Inspection points
1A	Fuse (15A)	Constant		$V_B$	<ul style="list-style-type: none"> <li>• Fuse</li> <li>• Related harness</li> </ul>
1B	Main relay (Power)	Ignition SW	ON	$V_B$	<ul style="list-style-type: none"> <li>• Main relay</li> <li>• Related harness</li> </ul>
			3 sec. after ignition switch OFF	1.0 max.	
1C	Glow plug relay	Engine coolant temperature below 60 °C	Ignition SW ON and for 15 sec.	$V_B$	<ul style="list-style-type: none"> <li>• Glow plug relay</li> <li>• Related harness</li> </ul>
			15 sec. after ignition SW ON	1.0 max.	
		Engine coolant temperature above 60 °C	While cranking	$V_B$	
			While idling	1.0 max.	
1D	Spill valve relay	Ignition SW	ON	Approx.0.36	<ul style="list-style-type: none"> <li>• Spill valve relay</li> <li>• Related harness</li> </ul>
			OFF	0	
		While idling		Approx.0.45	
		While ignition SW ON till just after OFF		$V_B$ 1.0 max.	
1E	Main relay	Ignition SW	ON	1.0 max.	<ul style="list-style-type: none"> <li>• Main relay</li> <li>• Related harness</li> </ul>
			OFF	$V_B$	
		While idling		1.0 max.	
1F	Ignition SW	Ignition SW	ON	$V_B$	<ul style="list-style-type: none"> <li>• Ignition SW</li> <li>• Related harness</li> </ul>
			OFF	1.0 max.	
1G	—	—		—	—
1H	—	—		—	—
1I	—	—		—	—
1J	TCM (Engine coolant temp. signal)	—		—	—
1K	EGR solenoid vacuum valve	Ignition SW	ON	$V_B$	<ul style="list-style-type: none"> <li>• EGR solenoid vacuum valve</li> <li>• Related harness</li> </ul>
			OFF	1.0 max. after approx. 3 sec.	
		While idling		$V_B$	
1L	—	—		—	—
1M	Glow light	Ignition SW	Several sec. after ignition switch ON	$V_B$	<ul style="list-style-type: none"> <li>• Glow light</li> <li>• Related harness</li> </ul>
			OFF	1.0 max.	
1N	—	—		—	—
1O	EGR solenoid vent valve	Ignition SW	ON	$V_B$	<ul style="list-style-type: none"> <li>• EGR solenoid vent valve</li> <li>• Related harness</li> </ul>
			OFF	1.0 max. after approx. 3 sec.	
		While idling		1.0 max.	

$V_B$ : Battery positive voltage

Terminal	Connected to	Measuring condition		Voltage (V)	Inspection points
1P	—	—		—	—
1Q	A/C amplifier (A/C cut)	A/C operating		V <sub>B</sub>	<ul style="list-style-type: none"> <li>• A/C amplifier</li> <li>• Related harness</li> </ul>
		A/C operation is cut		1.0 max.	
1R	Tachometer on combination meter	Ignition SW ON		1.0 max.	<ul style="list-style-type: none"> <li>• Related harness</li> </ul>
1S	A/C SW	Ignition SW	ON and A/C SW ON	V <sub>B</sub>	<ul style="list-style-type: none"> <li>• A/C SW</li> <li>• Related harness</li> </ul>
			OFF	1.0 max.	
1T	—	—		—	—
1U	Starting motor	While cranking		Approx. 10	<ul style="list-style-type: none"> <li>• Starter</li> <li>• Related harness</li> </ul>
		Other than above		1.0 max.	
1V	Transmission range SW (for A/T)	Ignition SW ON	P or N range	1.0 max.	<ul style="list-style-type: none"> <li>• Transmission range switch</li> <li>• Related harness</li> </ul>
			Other ranges	V <sub>B</sub>	
3A	Power to TP sensor	Ignition SW	ON	5.0	<ul style="list-style-type: none"> <li>• Sensor</li> <li>• Related harness</li> </ul>
			OFF	1.0 max.	
3B	Sensor ground	Constant		1.0 max.	<ul style="list-style-type: none"> <li>• Related harness</li> </ul>
3C	Boost sensor	Ignition SW ON and Barometric pressure:760 mmHg		Approx. 2.6	<ul style="list-style-type: none"> <li>• Boost sensor</li> <li>• Related harness</li> </ul>
3D	Immobilizer control module (if equipped)	Ignition SW	ON	Approx. 5.0	<ul style="list-style-type: none"> <li>• Immobilizer control module</li> <li>• Related harness</li> </ul>
			OFF	1.0 max. after approx. 3 sec.	
3E	IAT sensor	Ignition switch ON and ambient temp. :20 °C (68 °F)		Approx. 3.0	<ul style="list-style-type: none"> <li>• IAT sensor</li> <li>• Related harness</li> </ul>
3F	TP sensor	Ignition SW	Closed throttle position	0.46	<ul style="list-style-type: none"> <li>• TP sensor</li> <li>• Related harness</li> </ul>
			Wide open throttle	3.1	
3G	ECT sensor	—		—	—
3H	TP sensor (Closed throttle position SW signal)	Ignition SW	Closed throttle position	0	<ul style="list-style-type: none"> <li>• TP sensor</li> <li>• Related harness</li> </ul>
			Other than closed throttle position	V <sub>B</sub>	

**V<sub>B</sub>: Battery positive voltage**

Terminal	Connected to	Measuring condition		Voltage (V)	Inspection points	
3I	Fuel temp. sensor	Ignition switch ON and fuel temp. 60 °C (140 °F)		Approx. 0.74	<ul style="list-style-type: none"> <li>Fuel temp. sensor</li> <li>Related harness</li> </ul>	
3J	EGR position sensor	Ignition SW ON		Approx. 0.5	<ul style="list-style-type: none"> <li>EGR position sensor</li> <li>Related harness</li> </ul>	
		While idling		1.0 max.		
				Approx. 2.0		
3K	θ compensation resistance	Ignition SW	ON	Approx. 0.2 – 4.5	<ul style="list-style-type: none"> <li>θ compensation resistance</li> <li>Related harness</li> </ul>	
			3 sec. after OFF	1.0 max.		
3L	γ compensation resistance	Ignition SW	ON	Approx. 0.2 – 4.5	<ul style="list-style-type: none"> <li>γ compensation resistance</li> <li>Related harness</li> </ul>	
			3 sec. after OFF	1.0 max.		
3M	Glow plug relay	Ignition SW	ON and for approx. 15 sec.	Engine coolant temp. below 60 °C (140 °F)	Approx. 11	<ul style="list-style-type: none"> <li>Glow plug relay</li> <li>Related harness</li> </ul>
			OFF		1.0 max.	
		10 min. after idling		1.0 max.		
		While cranking	Engine coolant temp. more than 60 °C (140 °F)	V <sub>B</sub>		
		While idling		1.0 max.		
3N	–	–		–	–	
3O	–	–		–	–	
3P	TCM (Throttle position signal)	Ignition SW	Closed throttle position	Approx. 9.0	<ul style="list-style-type: none"> <li>Related harness</li> </ul>	
			Wide open throttle position	Approx. 5.0		
		Ignition SW OFF		1.0 max.		
4A	–	–		–	–	
4B	Ground	Constant		1.0 max.	<ul style="list-style-type: none"> <li>Related harness</li> </ul>	
4C	–	–		–	–	
4D	–	–		–	–	
4E	–	–		–	–	
4F	–	–		–	–	
4G	NE sensor (+)	Ignition SW	ON	Approx. 0.74	<ul style="list-style-type: none"> <li>NE sensor</li> </ul>	
			OFF	1.0 max. after approx. 3 sec.		
		Engine idling→racing		Approx. 0.72→ Approx. 0.69		
4H	NE sensor (–)	Ignition SW	ON	Approx. 0.74	<ul style="list-style-type: none"> <li>NE sensor</li> </ul>	
			OFF	1.0 max. after approx. 3 sec.		
				Engine idling→racing		Approx. 0.72→ Approx. 0.69

V<sub>B</sub>: Battery positive voltage

Terminal	Connected to	Measuring condition		Voltage (V)	Inspection points
4I	CKP sensor (+)	Ignition SW	ON	Approx. 0.68	<ul style="list-style-type: none"> <li>• CKP sensor</li> <li>• Related harness</li> </ul>
			OFF	1.0 max. after approx. 3 sec.	
		While idling		Approx. 0.65	
4J	CKP sensor (-)	Ignition SW	ON	Approx. 0.68	<ul style="list-style-type: none"> <li>• EGR position sensor</li> <li>• Related harness</li> </ul>
			OFF	1.0 max. after approx. 3 sec.	
		While idling		Approx. 0.65	
4K	-	-		-	-
4L	VSS	Ignition switch ON Rear left tire turned slowly with rear right tire locked		Indicator deflection repeated between 0 - 1 and 4 - 5 V	<ul style="list-style-type: none"> <li>• VSS</li> <li>• Related harness</li> </ul>
4M	-	-		-	-
4N	-	-		-	-
4O	-	-		-	-
4P	Diagnosis SW terminal	Ignition SW ON	Diagnosis SW terminal opened	$V_B$	<ul style="list-style-type: none"> <li>• Related harness</li> </ul>
			Diagnosis SW terminal shorted	1.0 max.	
4Q	-	-		-	-
4R	-	-		-	-
4S	Intake shutter solenoid valve	Ignition SW	ON	1.0 max.	<ul style="list-style-type: none"> <li>• Related harness</li> </ul>
			OFF		
		While idling		$V_B$	
4T	-	-		-	-
4U	-	-		-	-
4V	-	-		-	-
4W	Timer control solenoid valve	Ignition SW	ON	$V_B$	<ul style="list-style-type: none"> <li>• Timer control valve</li> <li>• Related harness</li> </ul>
			OFF	1.0 max.	
		While idling		$V_B$	
4X	Spill valve	Ignition SW	ON	$V_B$	<ul style="list-style-type: none"> <li>• Spill valve</li> <li>• Related harness</li> </ul>
			OFF	1.0 max.	
		While idling		9.14	
		While racing		Approx. 11	
4Y	Ground	Constant		1.0 max.	<ul style="list-style-type: none"> <li>• Related harness</li> </ul>
4Z	Ground	Constant		1.0 max.	<ul style="list-style-type: none"> <li>• Related harness</li> </ul>

$V_B$ : Battery positive voltage

## ON-VEHICLE SERVICE

### GENERAL

When hoses are disconnected and system components are removed for service, reinstall components properly, and route and connect hoses correctly after service.

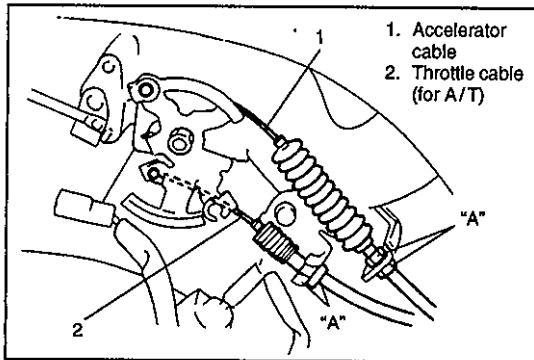

### ACCELERATOR CABLE AND A/T THROTTLE CABLE ADJUSTMENT

- 1) Warm up engine (engine coolant temp. 60°C (140°F) or over) and check cable play.

**Cable play: 1 – 3 mm (0.04 – 0.11 in.)**

- 2) If measured value is out of specification, adjust with nut "A".

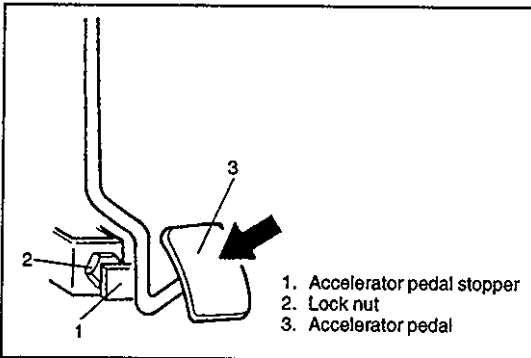

- 3) Depress accelerator pedal by hand and verify that the control lever contacts idle stopper and maximum stopper.
- 4) If not, adjust accelerator pedal stopper bolt so that control lever contacts maximum stopper.

### IDLE SPEED ADJUSTMENT

- 1) Shift transmission into Neutral (for M/T) or P range (for A/T).
- 2) Start engine and warm it up to normal operating temperature.
- 3) Turn all electrical loads off.
- 4) Using tachometer, verify that idle speed is within specification.

**Engine speed: 720 – 820 rpm**

- 5) Operate A/C and verify that engine speed is within specification.

**Engine speed: 750 – 850 rpm**

- 6) If not, refer to troubleshooting "Rough idle" under "Engine Diagnosis Table" In SECTION 6.

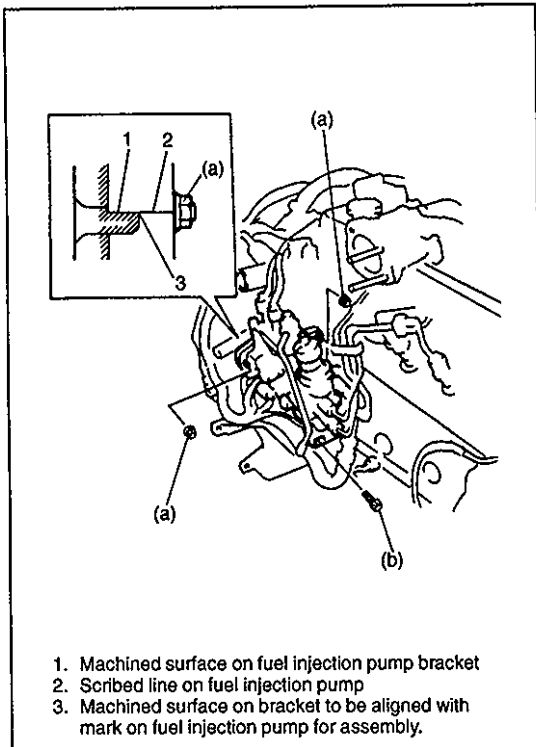

## INJECTION TIMING ADJUSTMENT

- 1) Loosen two fuel injection pump mounting nuts and one bolt.
- 2) Align matching marks on fuel injection pump bracket and on fuel injection pump.
- 3) Tighten fuel injection pump mounting nuts and bolt.

### Tightening Torque

(a): 22 N·m (2.2 kg-m, 16.0 lb-ft)

(b): 45 N·m (4.5 kg-m, 32.5 lb-ft)

## DIESEL SMOKE INSPECTION

- 1) Completely warm up engine and set a diesel smoke tester (opacimeter).

### CAUTION:

**Insert tester probe into downstream of exhaust pipe as far as possible.**

- 2) While engine is still hot, perform following steps at least 6 times.
  - i) Shift gear in neutral (for M/T) or P range (for A/T).
  - ii) Keep engine idle for a while.
  - iii) Fully depress accelerator pedal at once, and when maximum engine speed is obtained, release accelerator pedal.
  - iv) In above condition, note maximum absorption coefficient.
  - v) Let engine idle until opacimeter returns to initial condition.
- 3) For absorption coefficient judgement, average 4 coefficient values measured after it has been stabilized.

**Absorption coefficient concentration: 1.56 m<sup>-1</sup> max.**

- 4) If not within specification, inspect the air cleaner element, injection timing, fuel injection nozzle, and fuel injection pump.

# AIR INTAKE SYSTEM VACUUM HOSE ROUTING DIAGRAM

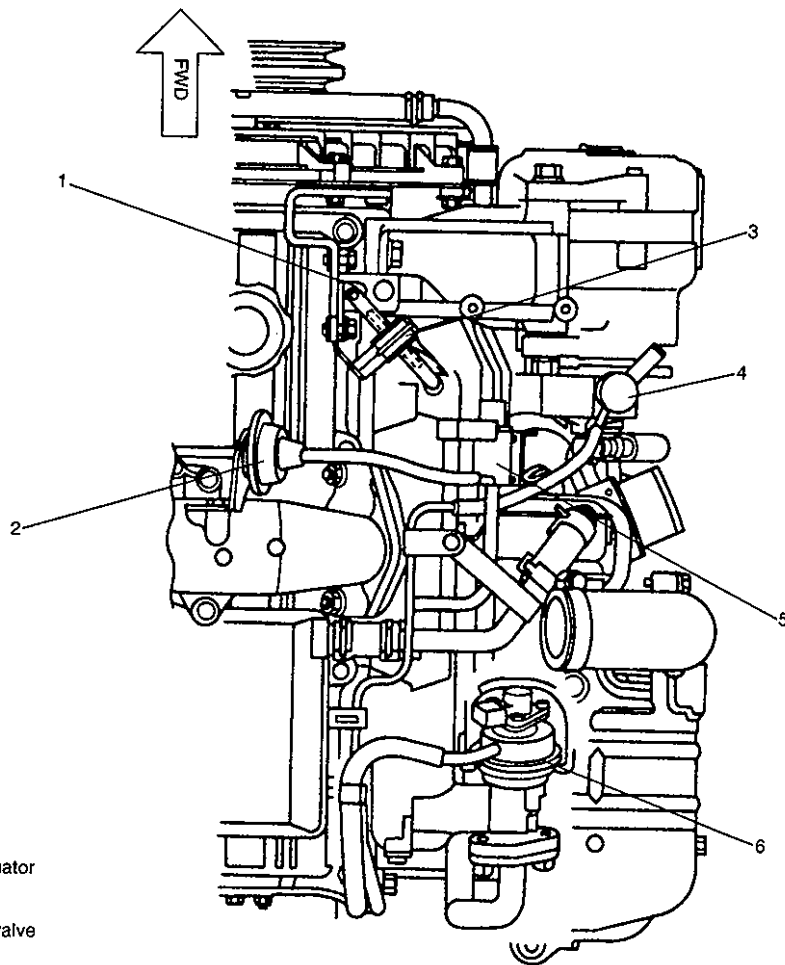

- 1. Boost sensor
- 2. Intake shutter valve actuator
- 3. Check valve
- 4. Vacuum pump
- 5. Intake shutter solenoid valve
- 6. EGR valve
- 7. EGR solenoid valve (vent)
- 8. EGR solenoid valve (vacuum)

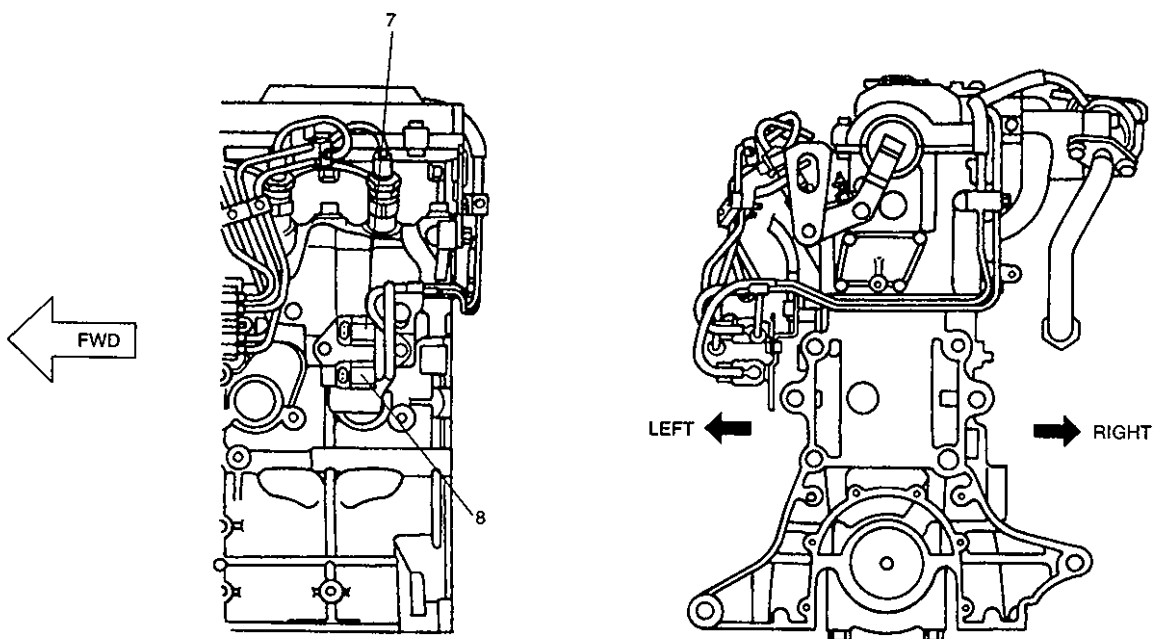

## AIR INTAKE SYSTEM PARTS REMOVAL AND INSTALLATION

- Remove in order shown in figure.
- For installation, reverse removal procedure and use new gasket "A".
- Tighten bolt and nut to specified torque.

### Tightening Torque

(a): 9 Nm (0.9 kg-m, 6.5 lb-ft)

(b): 22 Nm (2.2 kg-m, 16.0 lb-ft)

(c): 45 Nm (4.5 kg-m, 32.5 lb-ft)

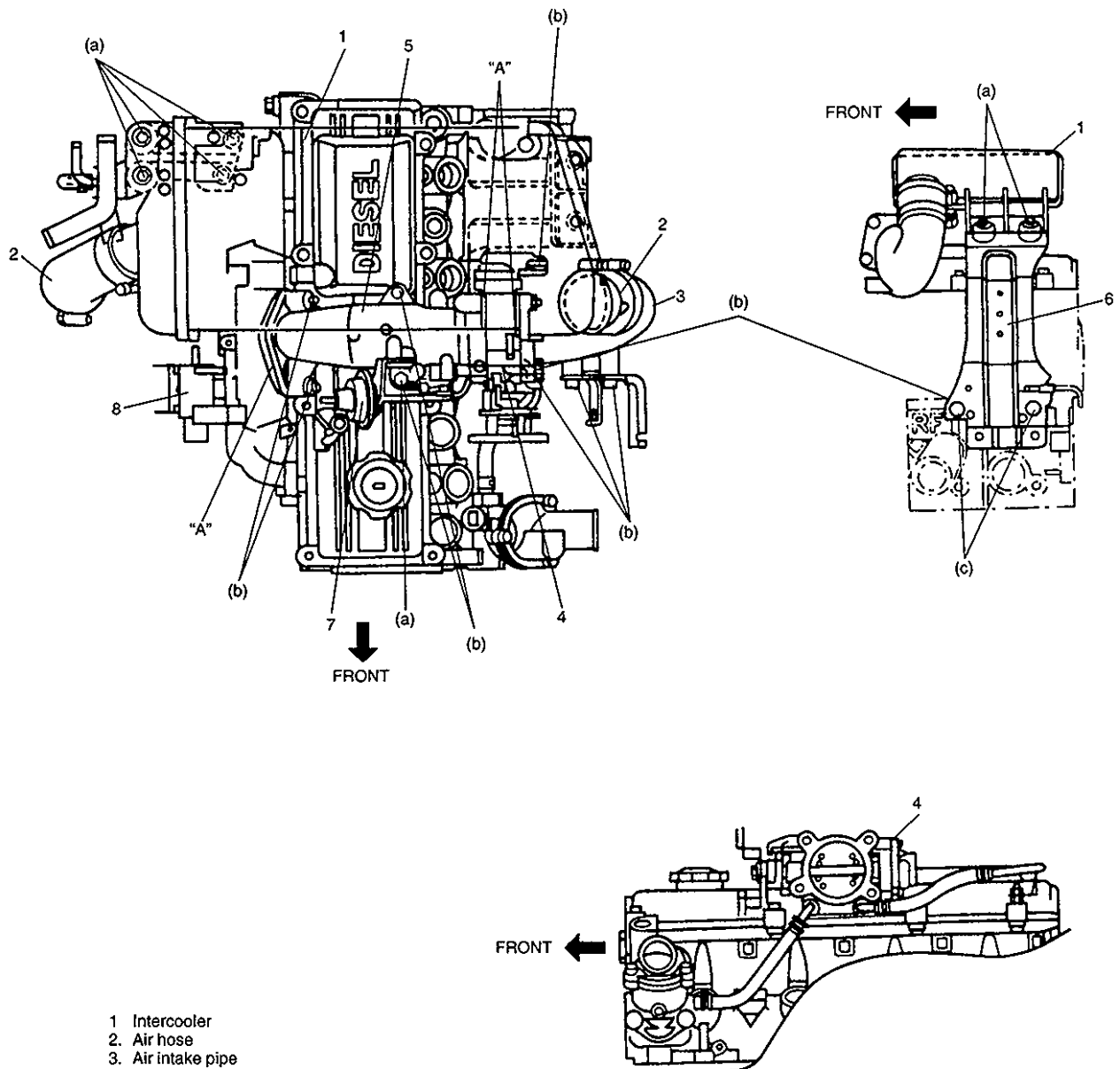

- 1 Intercooler
- 2 Air hose
- 3 Air intake pipe
- 4 Throttle body
- 5 Air intake pipe
- 6 Intercooler bracket
- 7 Intake shutter valve actuator
- 8 Intake shutter solenoid valve

"A": Gasket

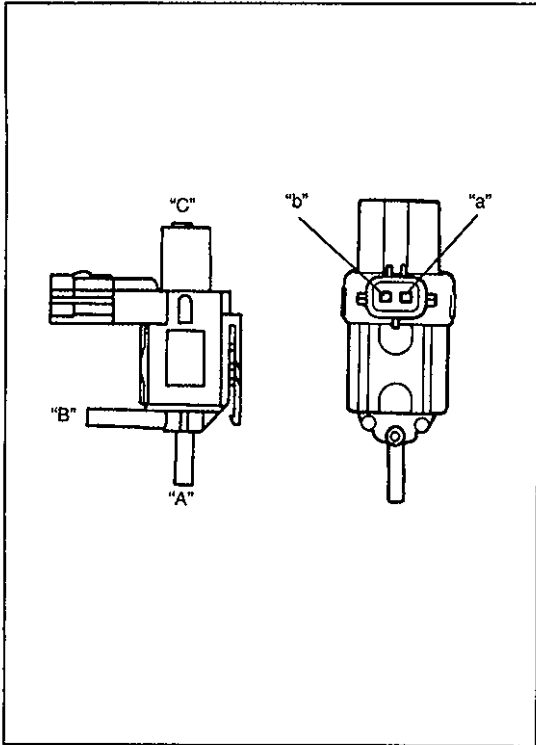

## INTAKE SHUTTER SOLENOID VALVE

### INSPECTION

Remove intake shutter solenoid valve and check for airflow between ports of solenoid valve.

- Blow into nozzle "B". Air should come out of filter "C" and not out of nozzle "A".
- Connect 12 V-battery to solenoid valve terminals ("a" and "b"). In this state, blow nozzle "A".

Air should come out of nozzle "B" and not out of filter.

If not as specified, replace intake shutter solenoid valve.

## INTAKE SHUTTER VALVE ACTUATOR

### INSPECTION

- 1) Connect a vacuum pump gauge (Special Tool) to intake shutter valve actuator.

#### Special Tool

(A): 09917-47910

- 2) Gradually increase vacuum and check for rod operation.

#### Rod operation starting vacuum:

0 – 3.6kPa (0 – 0.036 kg/cm<sup>2</sup>, 0 – 0.51 psi)

#### Rod operation completion vacuum:

–25.6 – 27.8 kPa

(–0.256 – 0.278 kg/cm<sup>2</sup>, –3.64 – 3.95 psi)

If not as specified, replace air intake pipe.

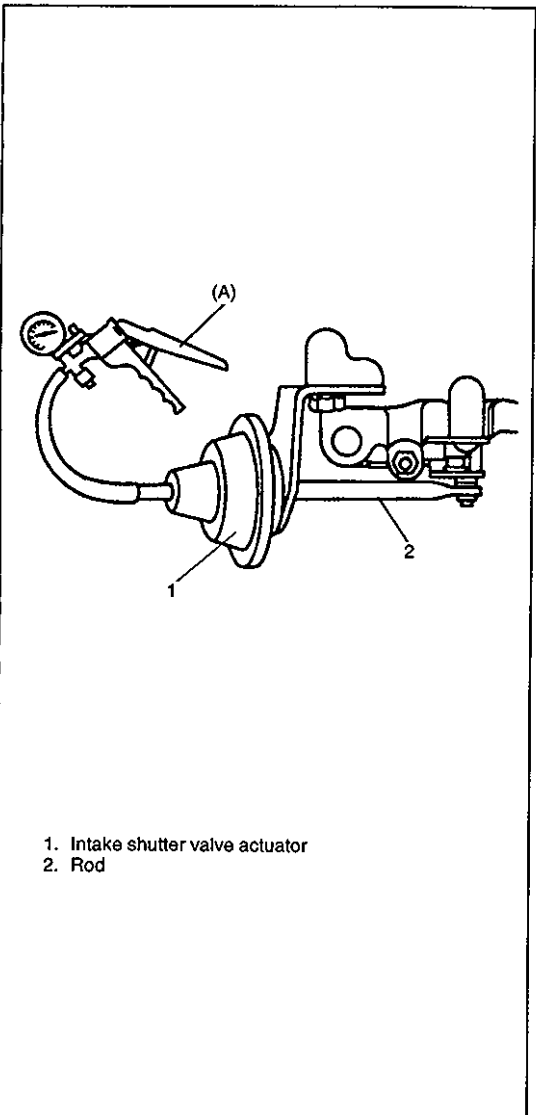

1. Intake shutter valve actuator
2. Rod

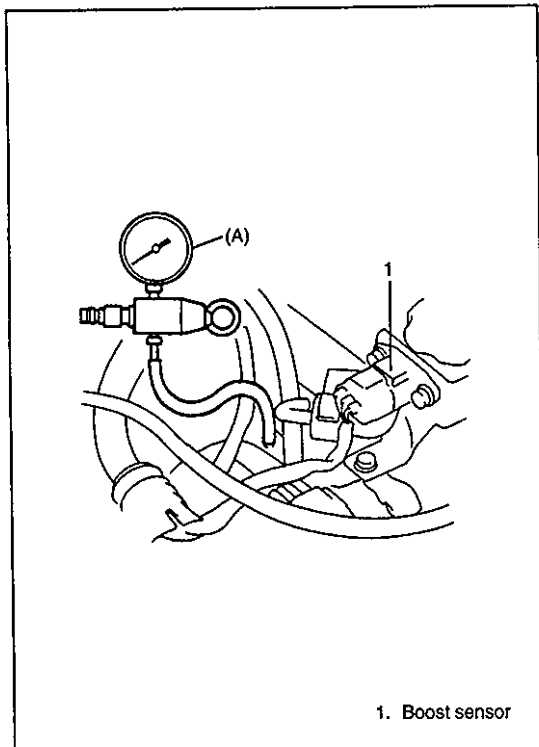

## TURBOCHARGER

### ON-VEHICLE INSPECTION

- 1) Disconnect vacuum hose between intake manifold and boost sensor at intake manifold side, and install special tool.

#### Special Tool

(A): 09918-18110

- 2) Start engine and warm it up to normal operating temperature.
- 3) While applying full load to engine (throttle valve fully open), measure charging pressure.

#### Charging pressure:

78.3 – 84.9 kPa (587 – 637 mmHg)

at engine speed: 2,500 rpm

If not as specified, check intake/exhaust system for leakage.

If there is no leakage, check wastegate valve actuator.

If actuator is normal, inspect turbocharger.

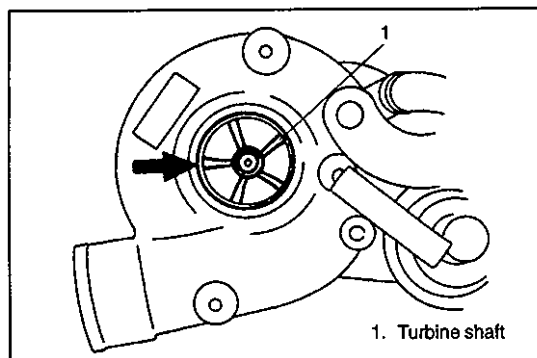

### TURBOCHARGER INSPECTION

- 1) Remove turbocharger. (Refer to "Intake and Exhaust System" in SECTION 6A3.)
  - 2) Rotate turbine shaft by hand and verify that it turns smoothly without any abnormal noise and excessive runout.
- If not as specified, replace the turbocharger.

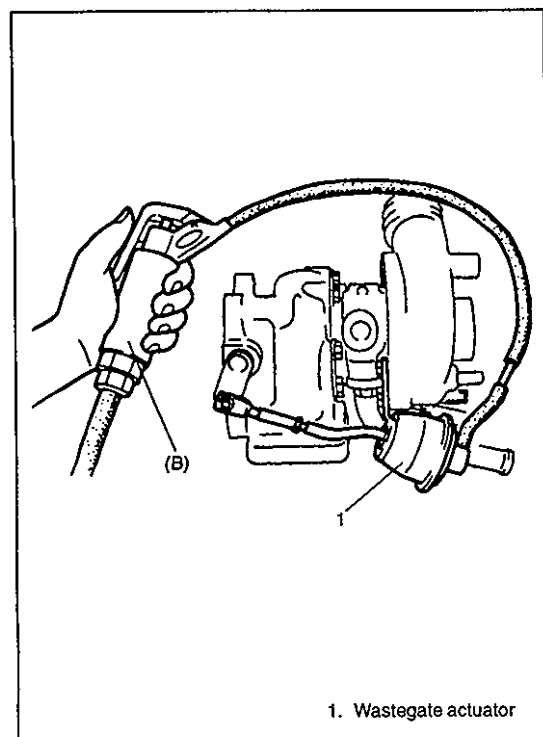

### WASTEGATE VALVE

- 1) Disconnect boost air hose.
- 2) Install special tool and apply compressed air.

#### Special Tool

(B): 09918-18110

- 3) Verify that wastegate actuator pulls rod at specified pressure.

#### Pressure:

96 – 100 kPa (0.96 – 1.00 kg/cm<sup>2</sup>, 13.7 – 14.2 psi)

If not, replace turbocharger. (Refer to "Intake and Exhaust System" in SECTION 6A3.)

#### CAUTION:

Do not apply more than 110 kPa (1.1 kg/cm<sup>2</sup>, 15.6 psi) pressure.

## QUICK START SYSTEM CONTROL

### SYSTEM INSPECTION

If engine startability is poor while engine is cold, or the quick start system has failed, check following systems. If there is a problem, inspect and repair or replace as necessary, referring to following table.

1) When ignition switch is turned to ON

When engine coolant temperature is lower than 60 °C (140 °F), while glow light turns ON, glow plug relay is energized, and glow plug relay is energized for approx. 15 seconds after glow light went out, then repeats ON-OFF cycle for approx. 15 seconds.

When engine coolant temperature is higher than 60 °C (140 °F), energization of glow plug relay and ON-OFF cycle are inhibited.

2) While cranking engine

Glow plug relay will be energized by ON-OFF cycle.

3) After engine start

When engine coolant temperature is lower than 60 °C (140 °F), glow plug relay is energized for approx. 10 minutes.

When engine coolant temperature is higher than 60 °C (140 °F), energization of glow plug relay is inhibited.

SYMPTOM	POSSIBLE CAUSE	ACTION
No voltage applied to glow plug	<ul style="list-style-type: none"> <li>● Faulty battery contact</li> <li>● Faulty ignition switch or switch contact</li> <li>● Burned ignition switch circuit fusible link or fuse</li> <li>● Faulty ignition switch circuit contact</li> <li>● Faulty ground circuit contact</li> <li>● Burned glow plug circuit fusible link</li> <li>● Glow plug relay will not turn "ON"</li> </ul>	Repair Repair or replace Replace Repair Repair Replace Repair or replace
Glow plug relay will not turn "ON"	<ul style="list-style-type: none"> <li>● Faulty glow plug relay</li> <li>● Poor contact or disconnection of glow plug relay coupler</li> <li>● Faulty ECM</li> <li>● Poor contact or disconnection of ECM coupler</li> </ul>	Replace Repair Replace Repair
Glow plug relay will not turn "OFF" after several seconds	<ul style="list-style-type: none"> <li>● Faulty glow plug relay</li> <li>● Faulty ECM</li> <li>● Poor contact or disconnection of ECM coupler</li> </ul>	Replace Replace Repair

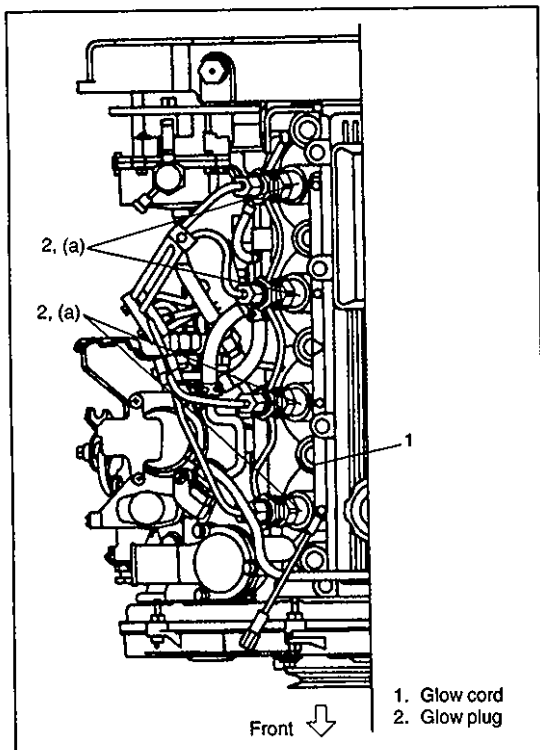

## GLOW PLUG

### REMOVAL AND INSTALLATION

#### CAUTION:

- Do not damage heating section of the glow plug.
- Do not use glow plug that has been dropped from height of over 10 cm (4 in.).
- When removing glow plug, first loosen it by using a tool so that one or more screw threads remain engaged, then loosen and remove by hand.

- Remove in order shown in figure.
- For installation, reverse removal procedure.
- Tighten glow plug to specified torque.

#### Tightening Torque

(a): 17 N·m (1.7 kg·m, 12.5 lb·ft)

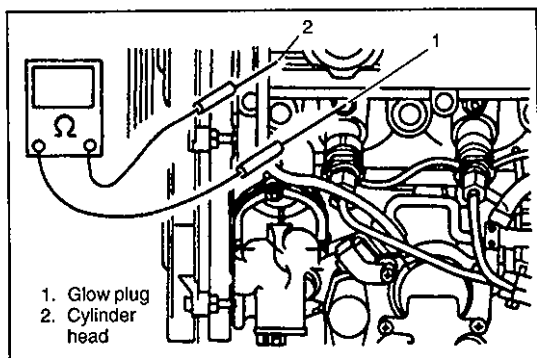

### INSPECTION

- 1) Disconnect glow plug cord, and measure resistance between glow plug positive terminal and cylinder head.

**Resistance: 2  $\Omega$  max.**

If resistance is not within specification, replace glow plug.

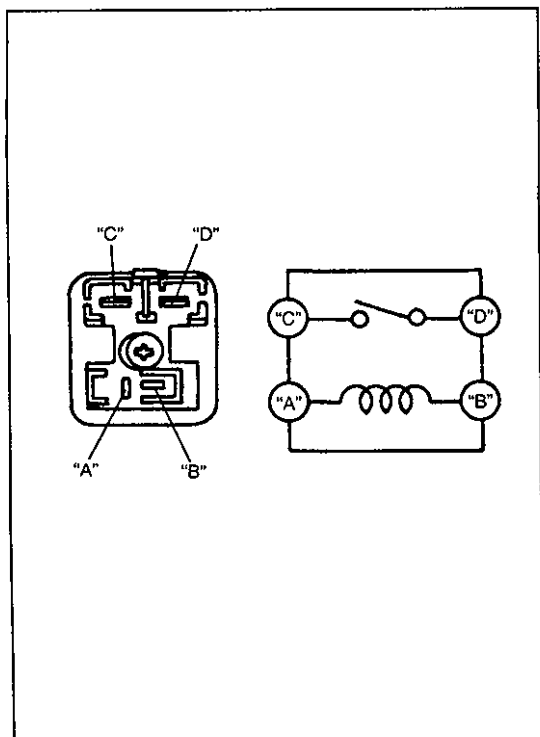

## GLOW PLUG RELAY

### INSPECTION

- 1) Remove glow plug relay.
- 2) Check resistance between each two terminals as in table below. If check results are as specified, proceed to next operation check. If not, replace.

TERMINALS	RESISTANCE
Between "A" and "B"	Continuity
Between "C" and "D"	No continuity

- 3) Check that there is continuity between terminals "C" and "D" when battery connected to terminals "A" and "B". If not as specified, replace.

## FUEL DELIVERY SYSTEM

### WARNING

- Fuel vapor is hazardous. It can very easily ignite, causing serious injury and damage. Always keep sparks and flames away from fuel. Fuel line spills and leaks are dangerous. Fuel can ignite and cause serious injuries or death and damage.
- Fuel can also irritate skin and eyes. To prevent this, always complete following "Precautions".

### PRECAUTIONS

- Before disconnecting a fuel hose, remove fuel filler cap to release pressure in fuel tank.
- When disconnecting a fuel hose, wrap rag around it to protect against fuel leakage. Plug disconnected hose.

### INJECTION NOZZLE

#### REMOVAL AND INSTALLATION

- 1) Disconnect negative battery cable.
- 2) Remove intercooler, air hose, and air intake pipe.
- 3) Remove in order indicated in figure, referring to "Precautions" above and "Removal/Installation Note" as follows.
- 4) Install in reverse order of removal, referring to "Removal/Installation Note" as follows.

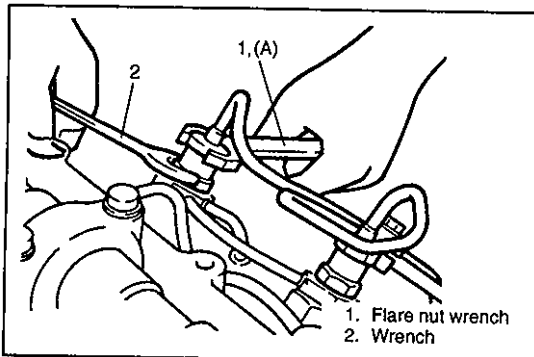
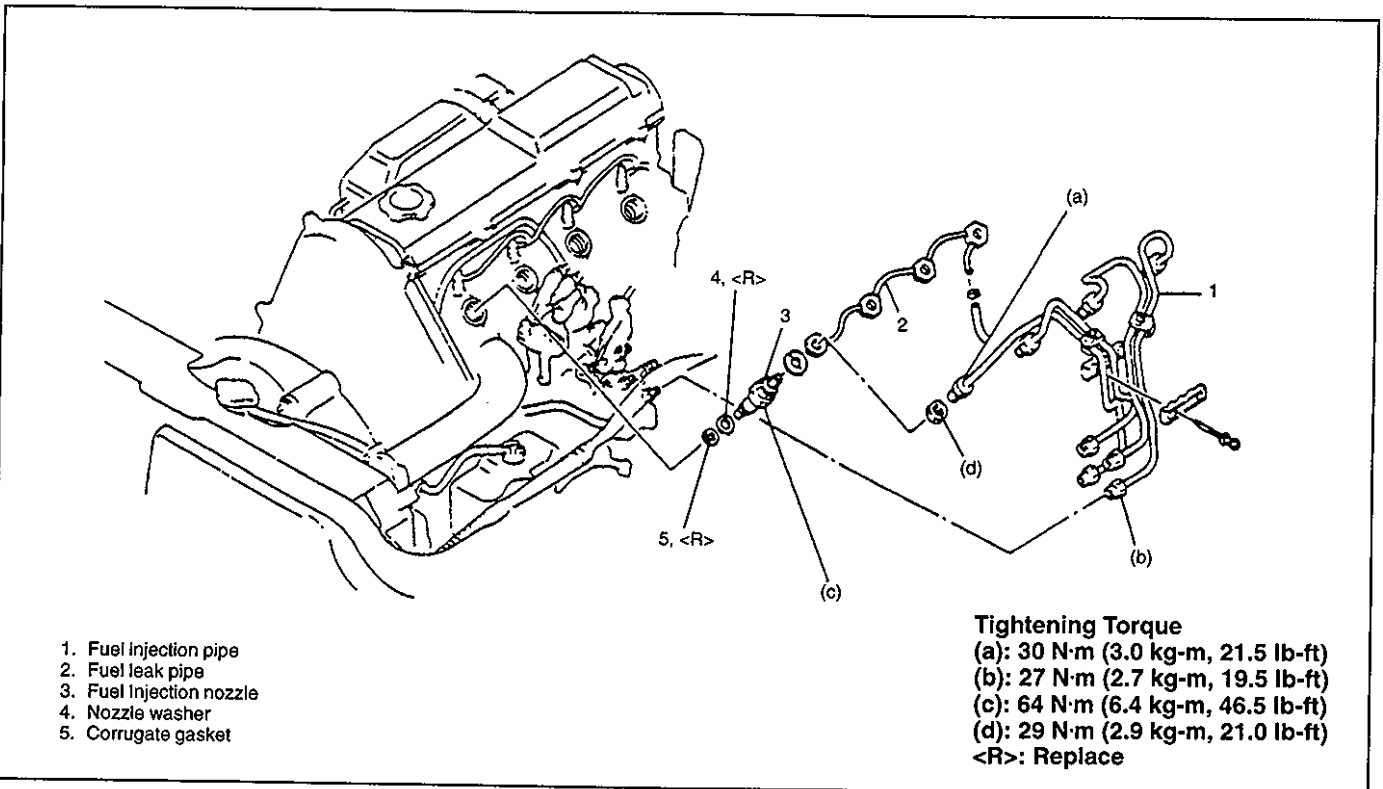

#### REMOVAL AND INSTALLATION NOTE

- When loosening flare nut of injection pipe, be sure to use special tool (flare nut wrench).

#### Special Tool

(A): 09950-76010

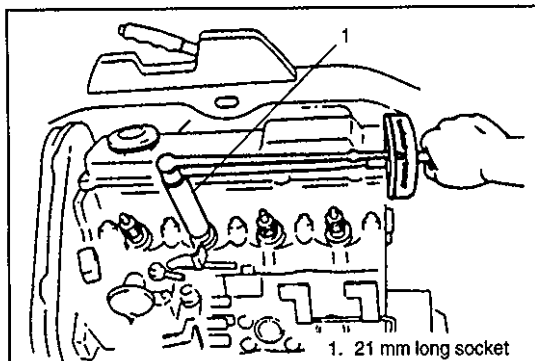

- Remove injection nozzle by using a socket wrench (with 21 mm) long socket.

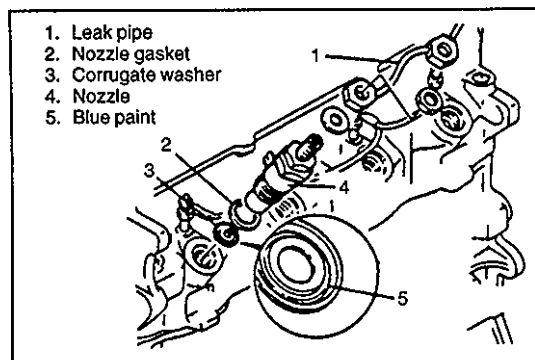

- Corrugated gasket must be installed with marked side (blue paint) facing upward.
- Tighten nozzle and nut to specified torque.

**Tightening Torque for Nozzle and Nut**  
64 N·m (6.4 kg·m, 16.5 lb·ft)

## INSPECTION

### Injection starting pressure

#### WARNING:

- Fuel vapor injected from injection nozzle is under high pressure. Never touch it in order to avoid being injured.
- Fuel vapor is highly flammable. Keep it from any open flames including cigarette.

#### CAUTION:

Fuel and fuel tank used for nozzle tester must be clean in order to prevent foreign material from being bound in nozzle seal.

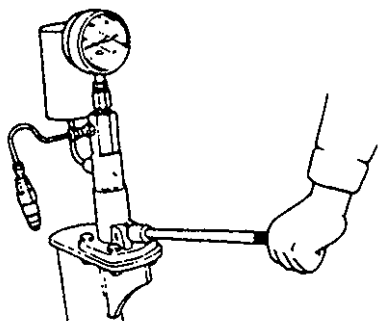

- 1) Install injection nozzle to nozzle tester.
- 2) Move pump lever of tester up and down several times to bleed air.
- 3) Slowly press pump lever to build up pressure and note pressure at moment when pressure gauge needle suddenly dropped.

#### Injection starting pressure (Reused nozzle):

14.3 – 15.1 MPa (143 – 151 kg/cm<sup>2</sup>, 2075 – 2191 psi)

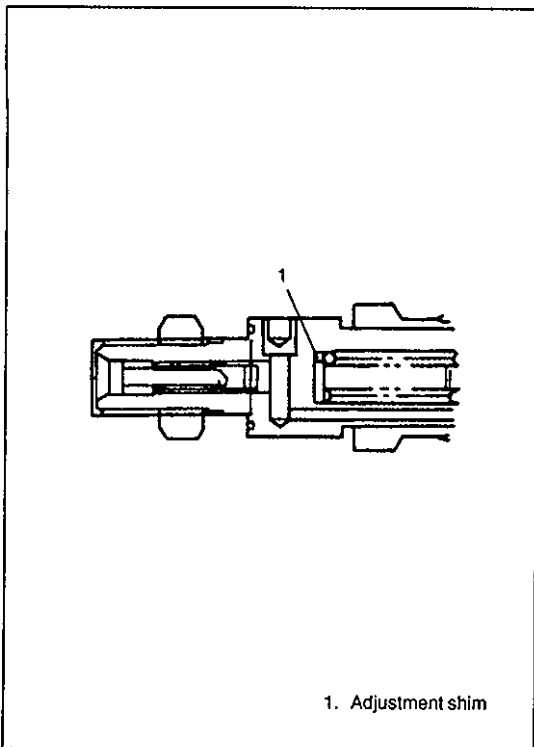

- 4) If not as specified, disassemble injection nozzle and adjust pressure by replacing adjustment shim.

**NOTE:**

Adjustment shims are available in 20 different thicknesses. Using one size (0.05 mm (0.0020 in.)) thicker/thinner shim changes starting pressure approx. 980 kPa (9.8 kg/cm<sup>2</sup>, 139 psi).

**Adjustment Shims mm (in.)**

1.00 (0.039)	1.40 (0.055)	1.80 (0.071)
1.05 (0.041)	1.45 (0.057)	1.85 (0.073)
1.10 (0.043)	1.50 (0.059)	1.90 (0.075)
1.15 (0.045)	1.55 (0.061)	1.95 (0.077)
1.20 (0.047)	1.60 (0.063)	—
1.25 (0.049)	1.65 (0.065)	—
1.30 (0.051)	1.70 (0.067)	—
1.35 (0.053)	1.75 (0.069)	—

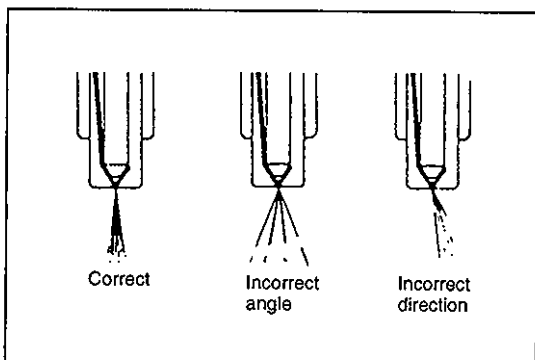

**Atomization condition**

- 1) Stop operation of pressure gauge of nozzle tester.
- 2) Operate pump lever 2 or 3 times and check injector atomization condition.

If not normal, disassemble and clean injection nozzle, recheck atomization condition, and replace nozzle if necessary.

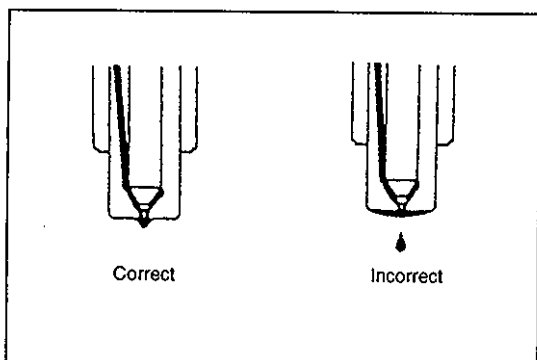

**Valve seat oil tightness**

- 1) Slowly press pump lever to apply pressure to injection nozzle. Check if fuel leaks from injection port of nozzle when pressure gauge indicated specified pressure.

**Pressure: 12.7 MPa (127 kg/cm<sup>2</sup>, 1806 psi)**

If fuel leaks, disassemble and clean injection nozzle, recheck fuel leakage, and replace nozzle if necessary.

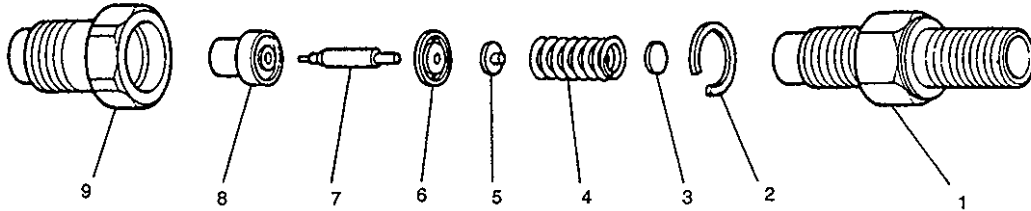
**DISASSEMBLY AND REASSEMBLY**

- |                       |                  |
|-----------------------|------------------|
| 1. Nozzle holder body | 6. Spacer        |
| 2. Ring               | 7. Needle valve  |
| 3. Shim               | 8. Nozzle body   |
| 4. Nozzle spring      | 9. Retaining nut |
| 5. Spring seat        |                  |

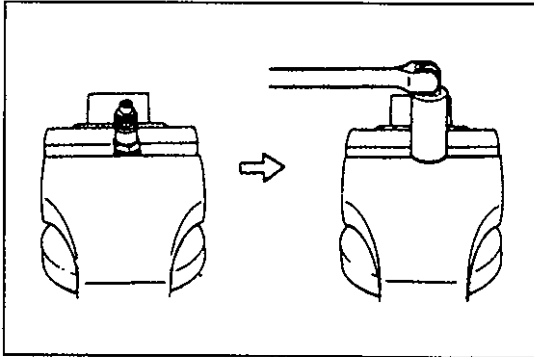
**DISASSEMBLY AND REASSEMBLY NOTE****Retaining nut and nozzle holder**

- Remove/install retaining nut and nozzle holder by using a socket wrench (with 21 mm) long socket. When installing, tighten nozzle holder body to specified torque.

**Tightening Torque for Nozzle Holder Body**

**37 N·m (3.7 kg-m, 27.0 lb-ft)**

**Nozzle body and needle valve**

- When either nozzle body or needle valve has failed and need to be replaced, both of them must be replaced as a set.
- Sub injection port must be kept free of dust and other foreign material because it is very small.

# INJECTION PUMP

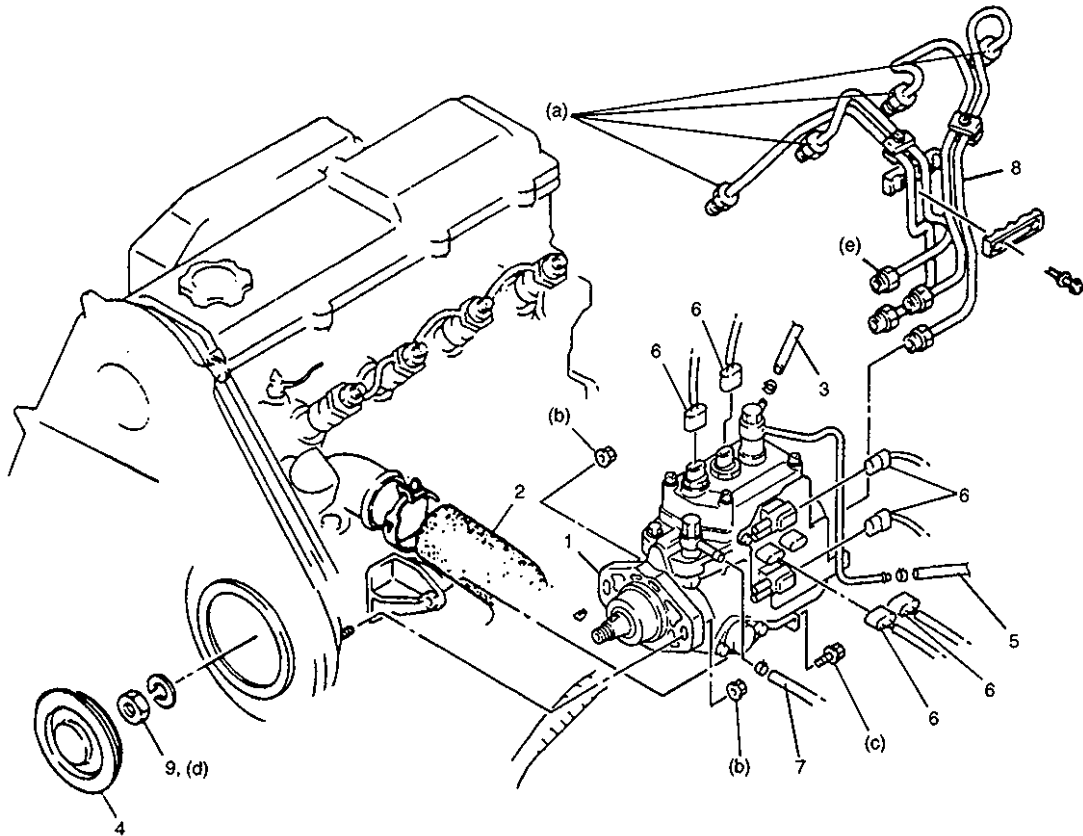

- |   |                                   |
|---|-----------------------------------|
| 1. Injection pump                       | 6. Coupler                        |
| 2. Radiator inlet hose                  | 7. Fuel hose (From fuel tank)     |
| 3. Fuel leak hose (From fuel leak pipe) | 8. Injection pipe                 |
| 4. Injection pump service hose cap      | 9. Injection pump pulley lock nut |

### Tightening Torque

- (a): 30 N·m (3.0 kg-m, 21.5 lb-ft)
- (b): 22 N·m (2.2 kg-m, 16.0 lb-ft)
- (c): 45 N·m (4.5 kg-m, 32.5 lb-ft)
- (d): 65 N·m (6.5 kg-m, 47.0 lb-ft)
- (e): 27 N·m (2.7 kg-m, 19.5 lb-ft)

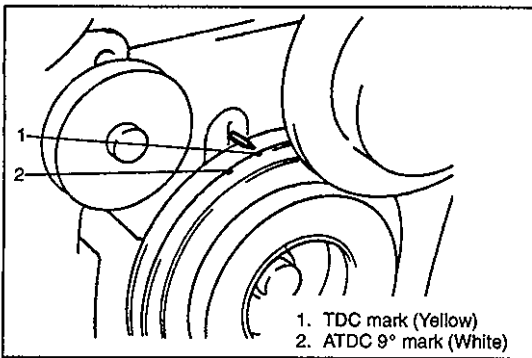

### NOTE:

Overhaul of injection pump requires use of special tools and testers, and therefore, pump is sealed to prevent unauthorized service.

### REMOVAL

- 1) Remove air intake pipe.
- 2) Position No.1 cylinder to compression TDC and remove timing belt.

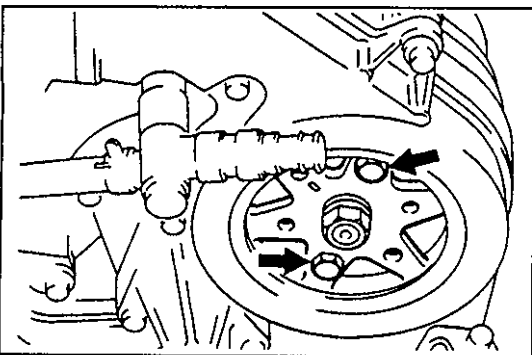

- 3) Fix pump pulley by using two bolts as shown, and remove pulley locknut.

**Bolts: M8, P1.25, 40 mm (1.59 in.) in length**

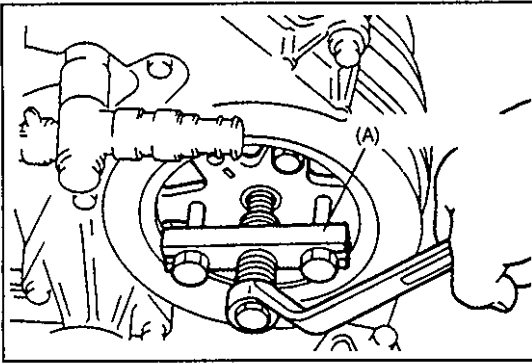

- 4) Leave bolts installed in step 2 in position and install special tool as shown in the figure.

**Special Tool**

(A): 09944-36011

- 5) Remove bolts, and remove pulley.
- 6) Remove coupler connections and hose connections, referring to structural view on previous page.
- 7) Remove pump side flare nut on the injection pipe.
- 8) Remove fuel injection pump.

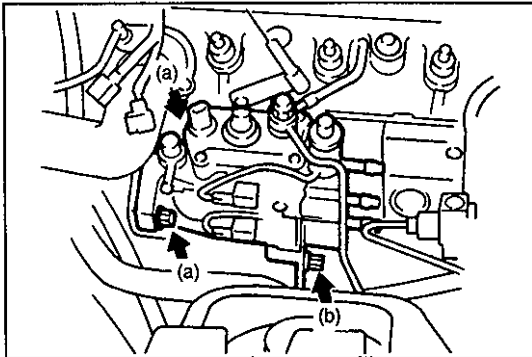

**INSTALLATION**

For installation, reverse removal procedure and note following precautions.

- Tighten bolt and nut that mounting pump to the specified torque.

**Tightening Torque**

(a): 22 N·m (2.2 kg-m, 16.0 lb-ft) (for nut)

(b): 45 N·m (4.5 kg-m, 32.5 lb-ft) (for bolt)

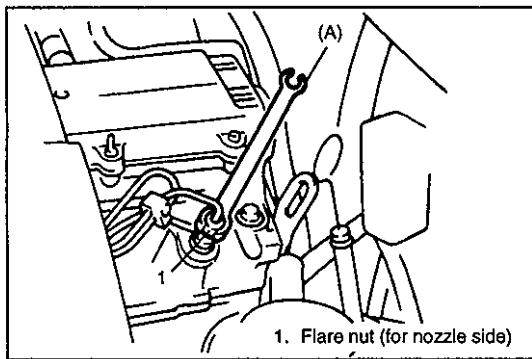

- Tighten injection pipe flare nut to specified torque by using special tool.

**Special Tool**

(A): 09950-76010

**Tightening Torque:**

30 N·m (3.0 kg-m, 21.5 lb-ft) (for nozzle side)

27 N·m (2.7 kg-m, 19.5 lb-ft) (for pump side)

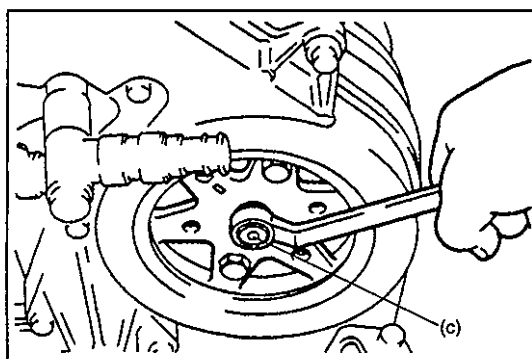

- Tighten pulley lock nut to specified torque.

**Tightening Torque**

(c): 65 N·m (6.5 kg-m, 47.0 lb-ft)

- After installation, perform air bleeding for fuel system (Refer to SECTION 6C.) and injection timing adjustment. (Refer to "Injection Timing Adjustment" earlier in this section.)

## ELECTRONIC CONTROL SYSTEM ENGINE CONTROL MODULE (ECM)

### CAUTION:

As ECM consists of precision parts, be careful not to expose it to excessive shock.

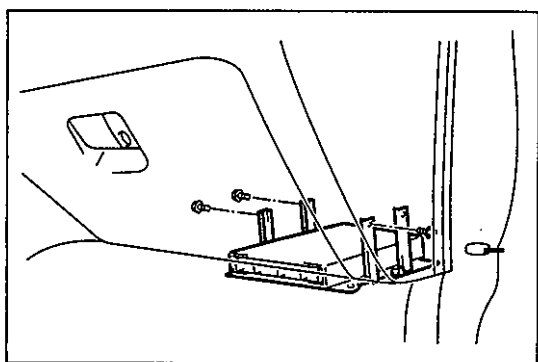
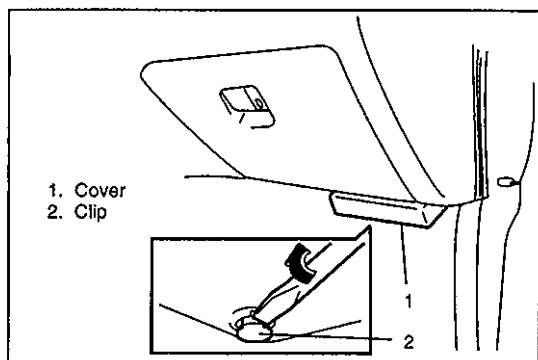

### REMOVAL

- 1) Disconnect battery negative cable from battery.
- 2) Disable air bag system (if equipped) referring to "Disabling the Air Bag System" in Air Bag System section.
- 3) Remove ECM cover from bracket.
- 4) Disconnect connectors from ECM.
- 5) Remove ECM with bracket.

### INSTALLATION

- 1) Install ECM with bracket to vehicle.
- 2) Connect connectors to ECM securely.
- 3) Install ECM cover to bracket.
- 4) Enable air bag system (if equipped) referring to "Enabling Air Bag System" in Air Bag system section.
- 5) Connect negative cable to battery.

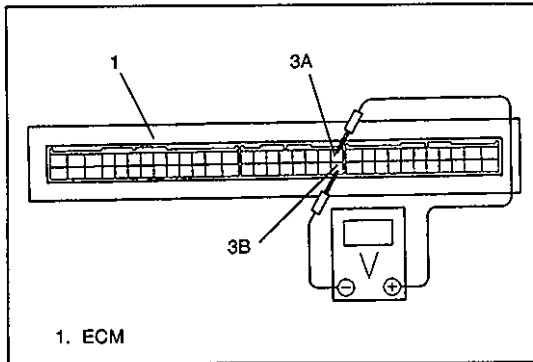

## BOOST SENSOR

### INSPECTION

- 1) Turn ignition switch to ON.
- 2) Measure voltage between ECM terminals "3A" and "3B".

**Voltage: Approx. 5 V**

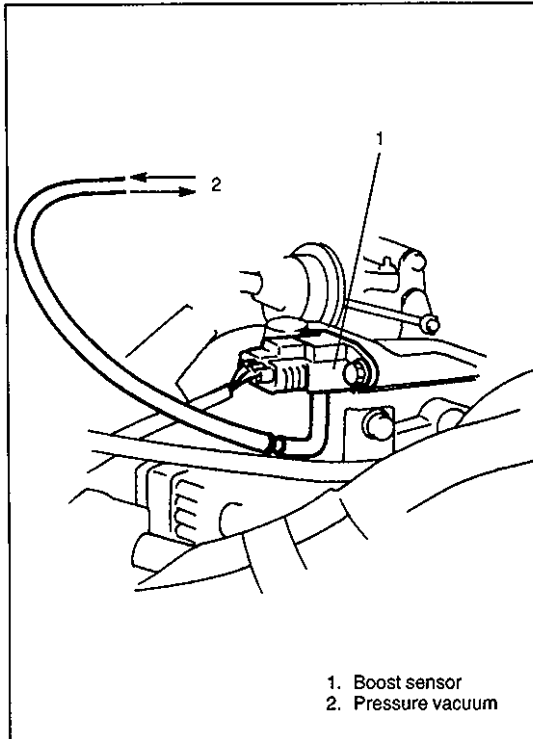

- 3) Disconnect vacuum hose from boost sensor.
- 4) Using a vacuum or pressure pump, apply vacuum or pressure to boost sensor as listed below, and measure voltage between ECM terminals "3C" and "3B".

kPa (mmHg)	Output voltage (V)
13.3 (100) – Pressure pump gauge value	Approx. 5
101 (760) – Vacuum pump gauge value	Approx. 0.75
101 (760) – Barometer value	Approx. 2.6

If not as specified, check related wiring harnesses. If they are normal, replace boost sensor.

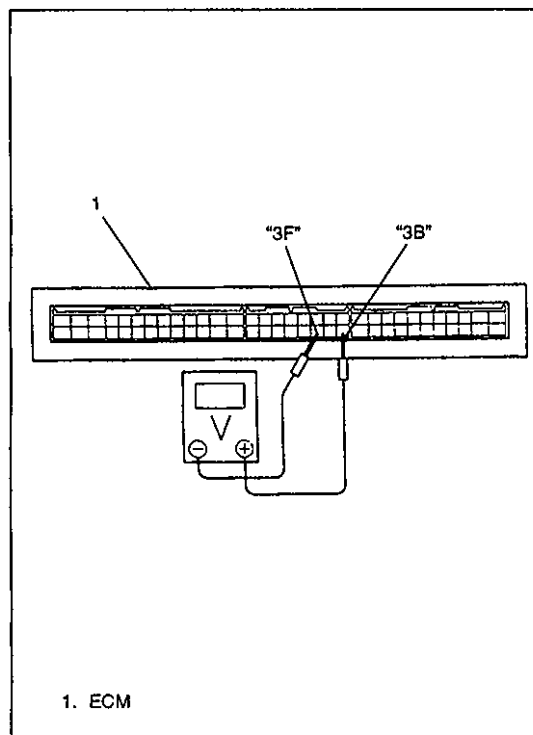

## TP SENSOR

### INSPECTION

- 1) Carry out "Closed Throttle Position Switch" later in this section.
- 2) Verify that throttle valve is fully closed.
- 3) Turn ignition switch to ON.
- 4) Measure voltage at ECM terminals "3F" and "3B" as follows.

**Voltage:**

**Closed throttle position : Approx. 0.6 V**

**Wide open throttle : Approx. 3.3 V**

If not as specified, check related wiring harnesses. If they are normal, replace TP sensor.

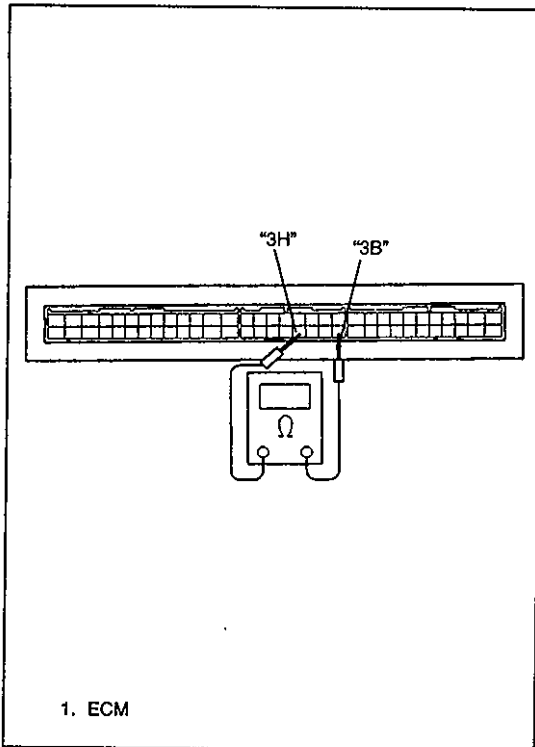

## CLOSED THROTTLE POSITION SWITCH

### INSPECTION

- 1) Verify that throttle valve is fully closed.
- 2) Turn ignition switch to OFF and disconnect ECM coupler.
- 3) Check for continuity between ECM terminals "3H" and "3B" as follows.

**Closed throttle position: Continuity**  
**Wide open throttle : No continuity**

- 4) If not as specified, check related wiring harnesses. If they are normal, carry out "Adjustment" as follows.

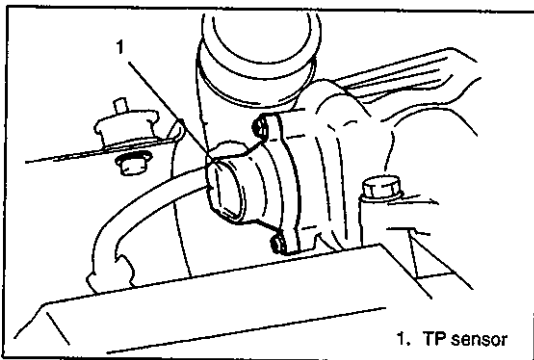

### ADJUSTMENT

- 1) Loosen TP sensor mounting screw, and hand-tighten it.

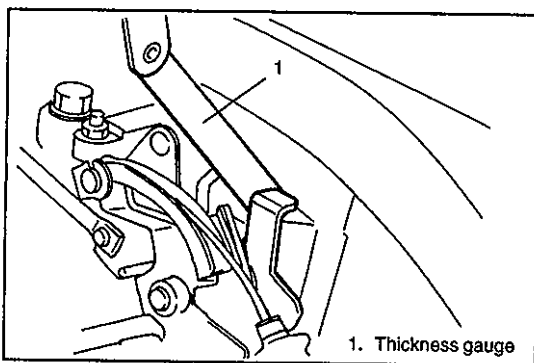

- 2) Adjust gap between throttle lever and closed throttle position stopper to 0.48 – 0.78 mm (0.02 – 0.03 in.).

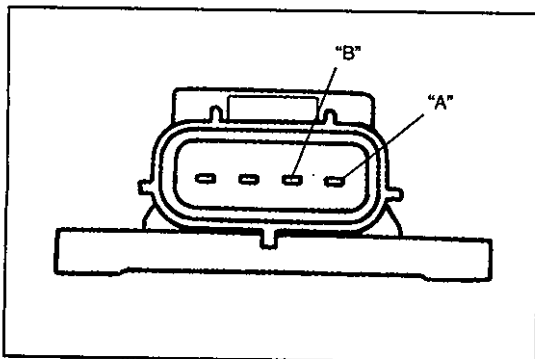

- 3) Turn ignition switch to ON.
- 4) Turn TP sensor until there is no more continuity between closed throttle position switch terminals "A" and "B".

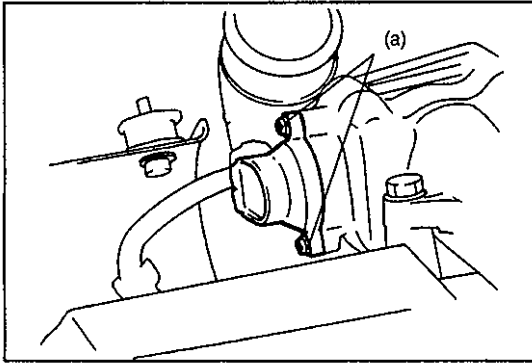

- 5) If continuity persists, replace TP sensor.
- 6) Tighten TP sensor screws to specified torque.

#### Tightening Torque

(a): 2 N·m (0.2 kg-m, 1.5 lb-ft)

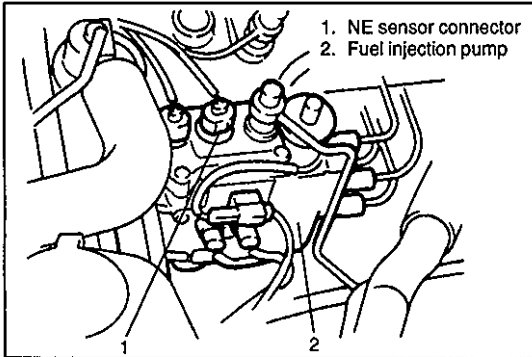

### NE SENSOR INSPECTION

- 1) Disconnect NE sensor connector on fuel injection pump.

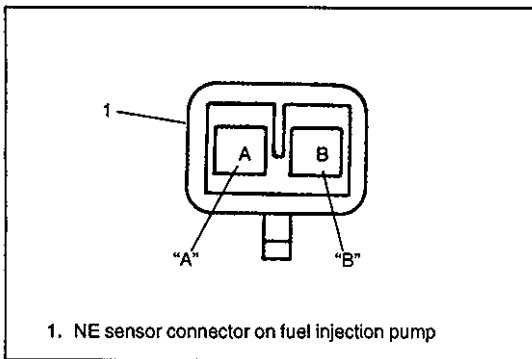

- 2) Verify that resistance between NE sensor terminals "A" and "B" is within specification.

**Terminals "A" – "B" : 100 – 200  $\Omega$**

**Terminal "B" – Ground: No continuity**

If not as specified, replace fuel injection pump.

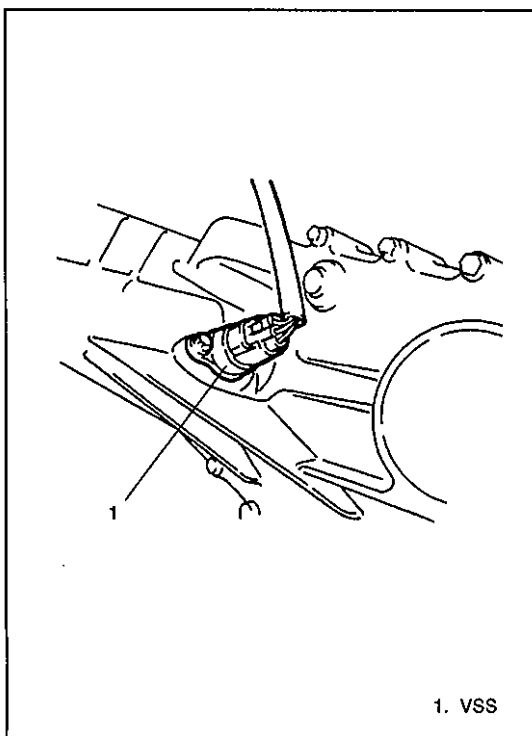

### VSS

#### ON-VEHICLE INSPECTION

- 1) Hoist vehicle.
- 2) Release parking brake lever, set transmission in neutral and transfer in "2H".
- 3) Remove ECM cover.
- 4) Connector voltmeter between terminal "4L" of ECM connector and body ground.
- 5) Turn ignition switch ON and turn rear right tire slowly with rear left tire locked.

Voltmeter should indicate deflection between 0 – 1 V and 8 – 14 V a few times while tire is turned one revolution.

If check result is not satisfactory, proceed to code No.24 of "Diagnostic Trouble Code Table" in this section.

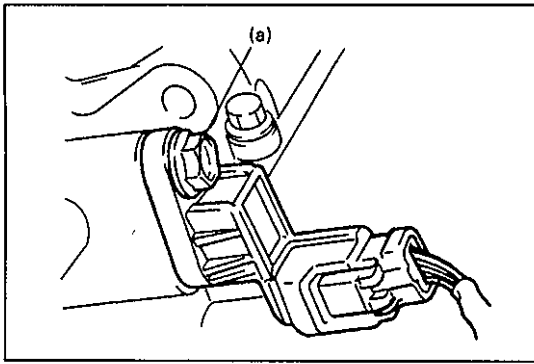

## REMOVAL, INSPECTION AND INSTALLATION

Refer to "VSS Removal, Inspection and Installation" in "Transfer" section.

### Tightening Torque

(a): 9 N·m (0.9 kg·m, 6.5 lb·ft)

## IAT SENSOR

### REMOVAL

- 1) Disconnect negative cable from battery.
- 2) Disconnect IAT sensor coupler.
- 3) Remove IAT sensor from air cleaner case.

### INSPECTION

Immerse temperature sensing part of IAT sensor in water (or ice) and measure resistance between sensor terminals while heating water gradually.

If measured resistance doesn't show such characteristic as shown in figure, replace IAT sensor.

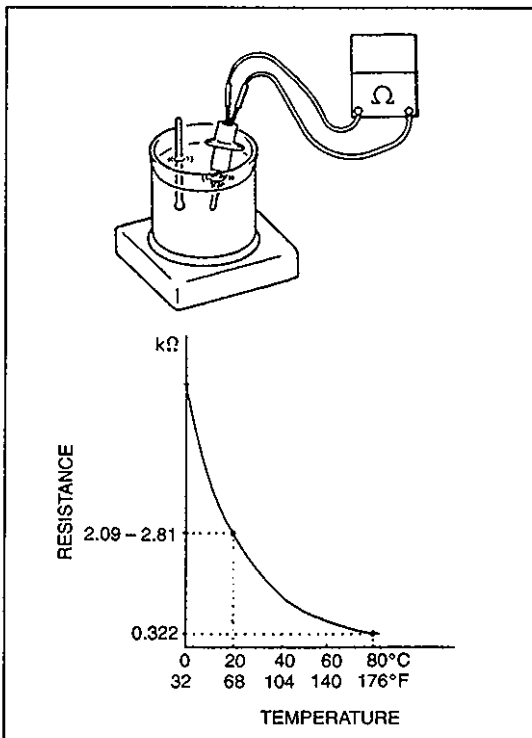

### INSTALLATION

- 1) Clean mating surface of sensor and seal on air cleaner case.
- 2) Install IAT sensor into seal.
- 3) Connect connector to IAT sensor securely.

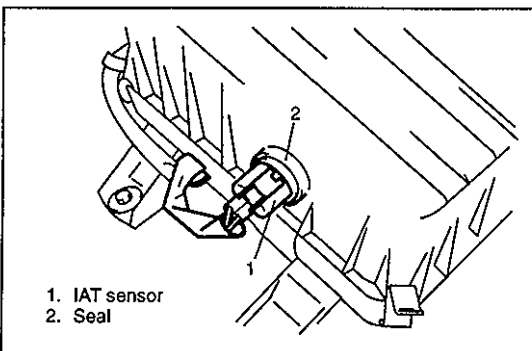

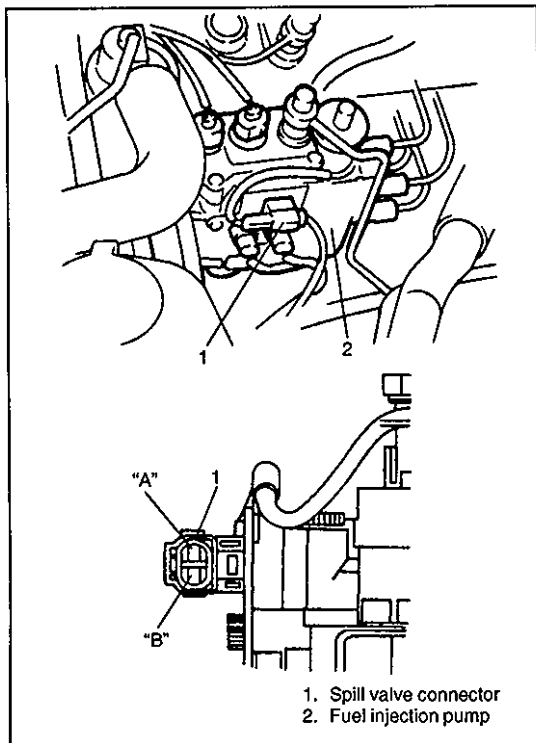
**SPILL VALVE****INSPECTION**

- 1) Disconnect spill valve connector on side of fuel injection pump.
- 2) Verify that resistance between spill valve connector terminals "A" and "B" is within specification.

Terminals "A" – "B" : 1 – 2  $\Omega$

Terminal "B" – Ground: No continuity

If not as specified, replace fuel injection pump.

**SPILL VALVE RELAY****INSPECTION**

- 1) Check resistance between each two terminals as in table below. If check results are as specified, proceed to step 2). If not, replace.

TERMINALS	RESISTANCE
Between "A" and "B"	No continuity
Between "C" and "D"	Continuity

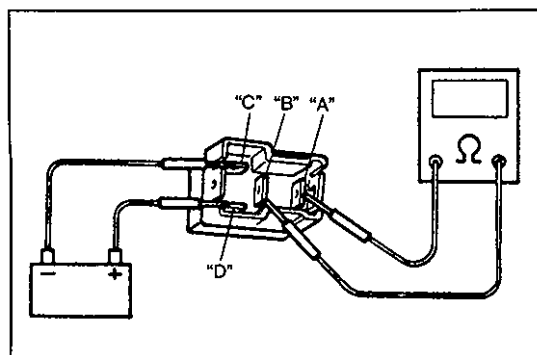
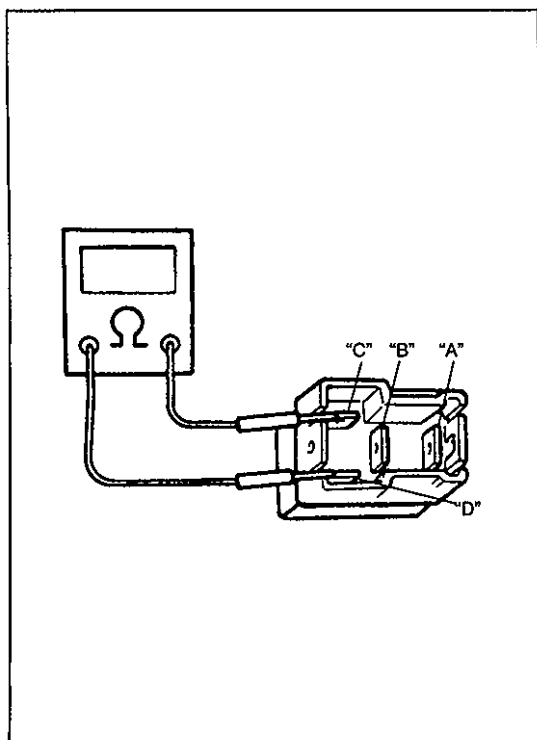

- 2) Check that there is continuity between terminals "A" and "B" when battery is connected to terminals "C" and "D". If found defective, replace.

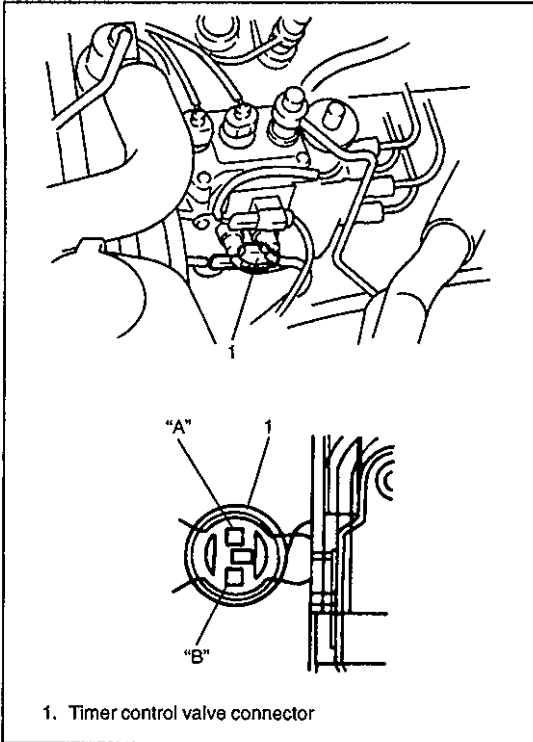

## TIMER CONTROL VALVE

### INSPECTION

- 1) Disconnect timer control valve connector on side of fuel injection pump.
- 2) Verify that resistance between timer control valve terminals "A" and "B" is within specification.

**Resistance: 10 – 14  $\Omega$**

If not as specified, replace fuel injection pump.

### Operation inspection

- 1) Disconnect timer control valve connector on side of fuel injection pump.
- 2) Apply battery positive voltage to timer control valve and verify that solenoid operation sound (a click) is heard.  
If not, replace fuel injection pump.

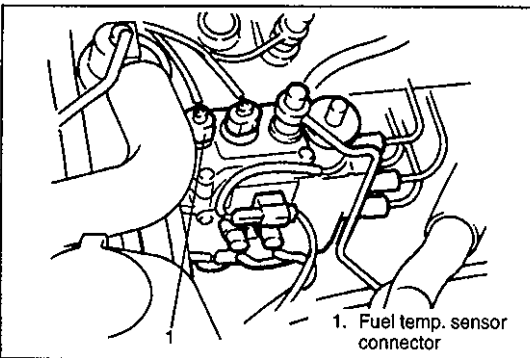

## FUEL TEMPERATURE SENSOR

### INSPECTION

- 1) Remove fuel temperature sensor on top of fuel injection pump.

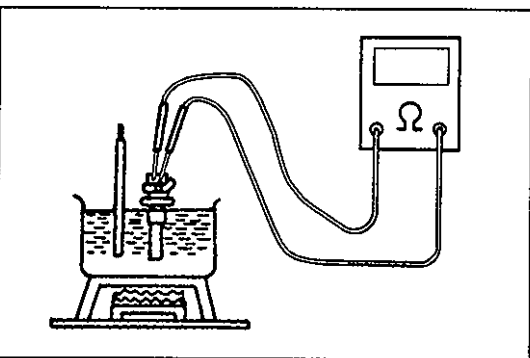

- 2) Place sensor and a thermometer in water. Heat water gradually and verify that resistance between fuel temperature sensor terminals at following temperatures is as specified.

Water temperature °C (°F)	Resistance (k $\Omega$ )
0 (32)	5.88 (Reference)
20 (68)	2 – 3
80 (176)	0.2 – 0.4

If not as specified, replace fuel temperature sensor.

**Tightening Torque for Fuel Temperature Sensor:  
22 N·m (2.2 kg·m, 16.0 lb·ft)**

- 3) Check O-ring for damage. If found defective, replace.

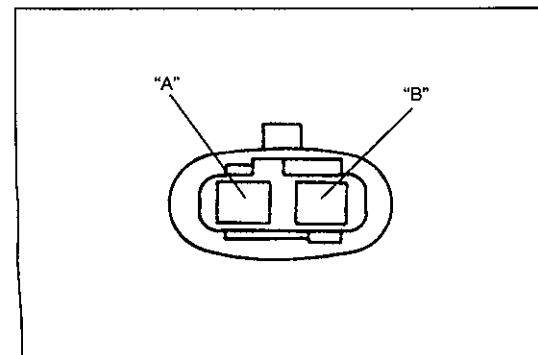
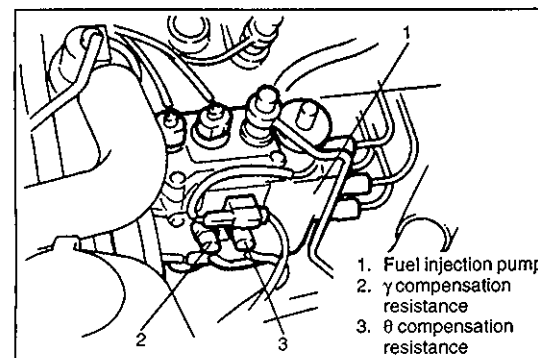
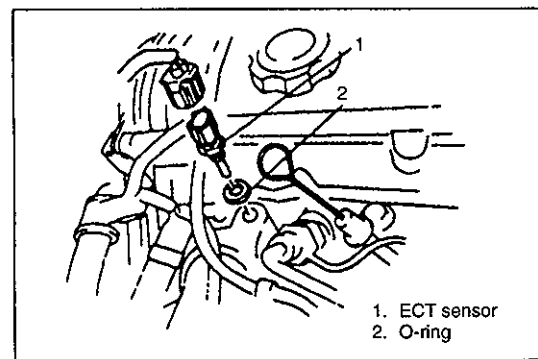
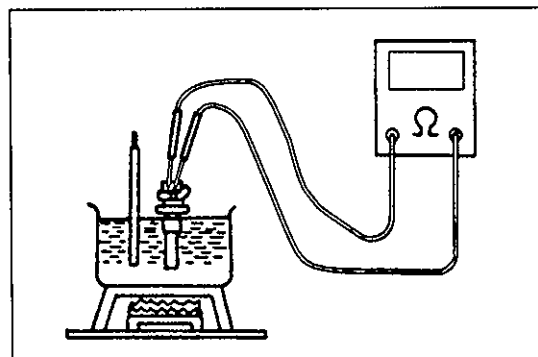
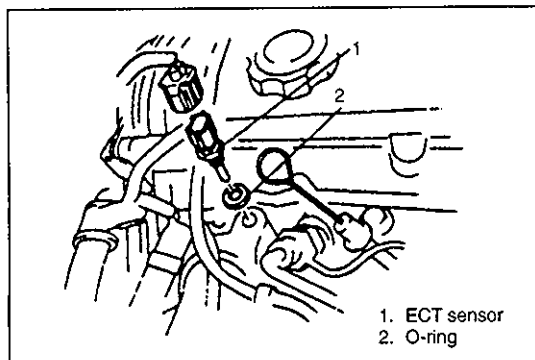

## ECT SENSOR

### INSPECTION

- 1) Drain engine coolant for approx. 2 ℓ (0.53/0.44 US/Imp gal).
- 2) Remove ECT sensor.

- 3) Place sensor and a thermometer in water. Heat water gradually and verify that resistance between ECT sensor terminals at following temperatures is as specified.

Water temperature °C (°F)	Resistance (k $\Omega$ )
0 (32)	5.88 (Reference)
20 (68)	2 – 3
80 (176)	0.2 – 0.4

If not as specified, replace ECT sensor.

#### NOTE:

When reinstalling ECT sensor, use new O-ring.

#### Tightening Torque for ECT Sensor:

27 N·m (2.7 kg·m, 19.5 lb·ft)

## COMPENSATION RESISTANCE

### INSPECTION

- 1) Disconnect compensation resistance connector on side of fuel injection pump.

- 2) Verify that resistance between connector terminals "A" and "B" for  $\gamma$  compensation resistance and  $\theta$  compensation resistance are within specification.

#### Resistance:

$\gamma$  compensation resistance: 0.05 – 1.5 k $\Omega$

$\theta$  compensation resistance: 0.1 – 2.5 k $\Omega$

If not as specified, replace fuel injection pump.

## CKP SENSOR

### INSPECTION

- 1) Disconnect CKP sensor connector.

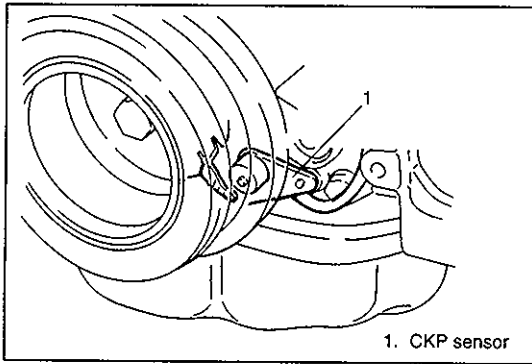

- 2) Verify that resistance between terminals "A" and "B" of connector is within specification.

**Resistance: Approx. 550 Ω max.**

If not as specified, replace CKP sensor.

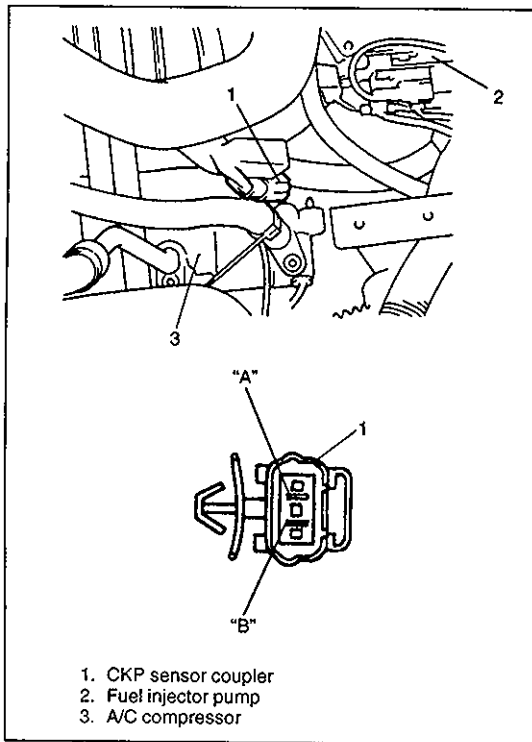

### AIR GAP INSPECTION

Verify that air gap between tip of timing belt guide signal plate on rear side of crankshaft pulley and CKP sensor is within specification.

**Gap "a": 2.5 – 3.5 mm (0.098 – 0.138 in.)**

If not as specified, replace timing belt guide signal plate or CKP sensor.

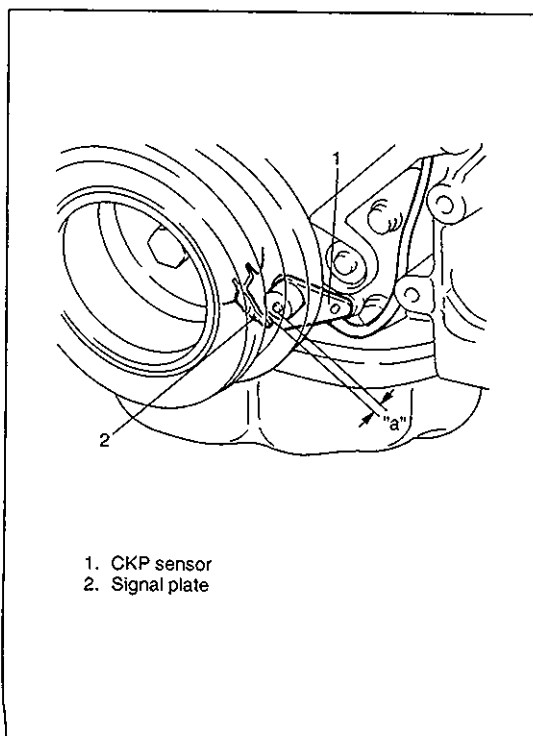

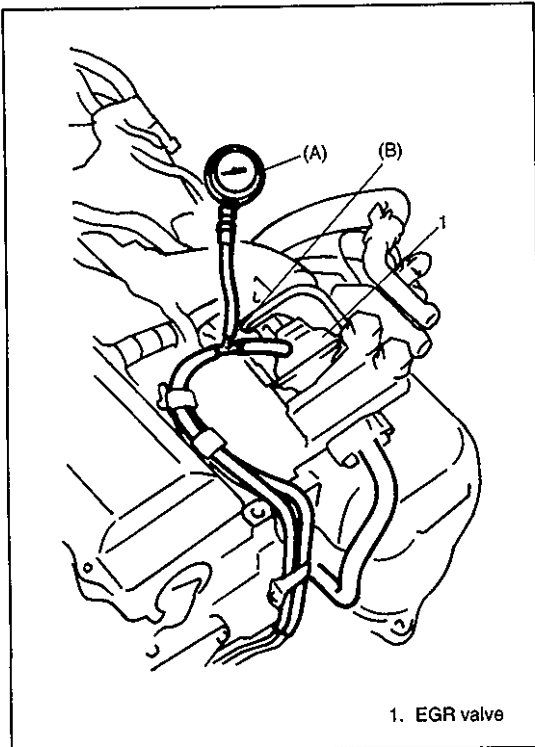

## EGR SYSTEM ON-VEHICLE INSPECTION

### NOTE:

Before inspection, check to make sure that gear shift lever is in Neutral position (M/T) or in P range (A/T) and that parking brake lever is pulled all the way up.

- 1) Install a vacuum gauge between EGR valve and solenoid valve.

### Special Tool

(A): 09915-67310

(B): 09918-08210

- 2) Measure vacuum when EGR is operated and not operated.

### Vacuum:

EGR operated :40 kPa (300 mmHg)

EGR not operated :6.7 kPa (50 mmHg)

### EGR operation conditions:

- Starter OFF
- Engine coolant temp. above 30 °C (86 °F)
- Engine speed over 500 rpm

### EGR non-operation conditions:

- While cranking the engine
- Engine coolant temp. below 27 °C (81 °F)
- Engine speed below 500 rpm

- 3) If EGR will not operate under EGR operation conditions, inspect EGR valve, EGR solenoid valve, EGR position sensor, and vacuum hose.

## VACUUM HOSE INSPECTION

Check hose for connection, leakage, clogs and deterioration. Replace as necessary.

## EGR VALVE

### INSPECTION

- 1) Using a vacuum pump, apply vacuum to diaphragm chamber. Check for airflow between ports "A" and "B".

**Vacuum:  $23.3 \pm 2.0$  kPa ( $175 \pm 15$  mmHg ) less than :**

**No airflow**

**Vacuum other than above :**

**Airflow**

**Special Tool**

**(A): 09917-47910**

- 2) Apply approx. 93.3 kPa (700 mmHg ) vacuum to diaphragm chamber and verify that gauge needle stabilized. If not as specified, replace EGR valve.

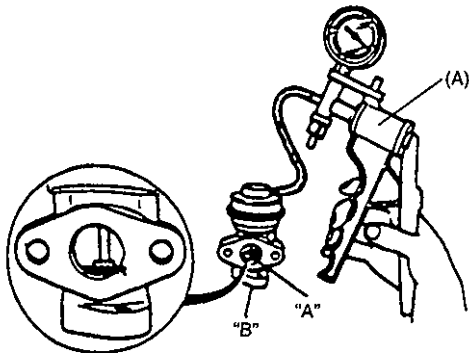

## EGR POSITION SENSOR

### INSPECTION

- 1) Disconnect EGR position sensor connector and measure resistance between terminals "A" and "B".

**Resistance: 4 – 6 kΩ**

- 2) Turn EGR valve from fully closed position to fully open position, and check for resistance change between terminals "A" and "B".

**Resistance increases in direct proportion to control lever opening angle.**

If not as specified, replace EGR position sensor.

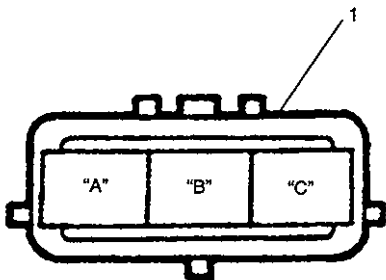

1. EGR position sensor connector

## EGR SOLENOID VACUUM VALVE

### INSPECTION

Check for airflow between "A" and "B" of solenoid valve

- Blow air into port "A". Air should not come out of port "B".
  - Apply battery positive voltage between terminals of valve connector, and blow air into port "A". Air should come out of port "B".
- If not as specified, replace EGR solenoid vacuum valve.

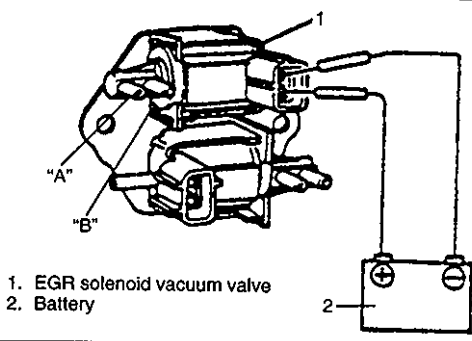

1. EGR solenoid vacuum valve  
2. Battery

**WARNING:**

Do not suck the air through valve. Fuel vapor inside valve is harmful.

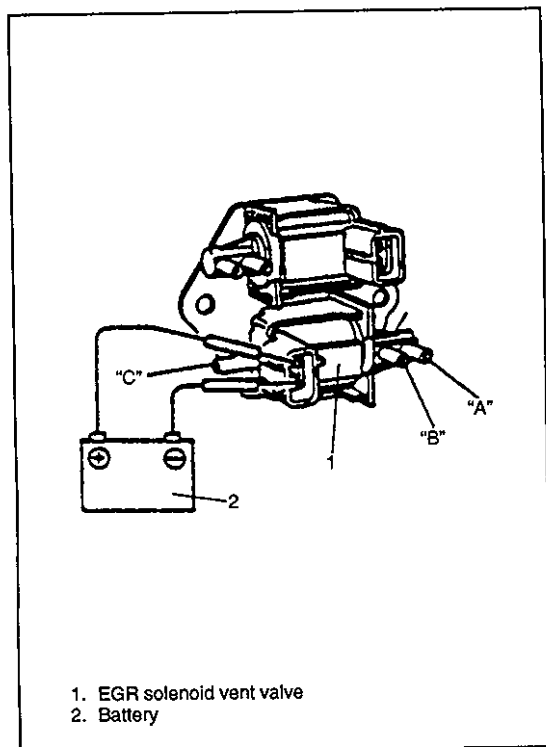
**EGR SOLENOID VENT VALVE****INSPECTION**

1) Blow air into valve through each port, and check for airflow.

“A” – “B”: Airflow

“A” – “C”: Airflow

“B” – “C”: Airflow

2) Apply battery positive voltage between terminals of valve connector, and check for airflow.

“A” – “B”: Airflow

“A” – “C”: No airflow

“B” – “C”: No airflow

If not as specified, replace EGR solenoid vent valve.

**WARNING:**

Do not suck the air through valve. Fuel vapor inside valve is harmful.

## TIGHTENING TORQUE SPECIFICATIONS

Fastening parts	Tightening torque		
	N-m	kg-m	lb-ft
Fuel injection pump mounting nut	22	2.2	16.0
Fuel injection pump mounting bolt	45	4.5	32.5
Intercooler	9	0.9	6.5
Intake shutter valve actuator			
Air intake pipe	22	2.2	16.0
Intercooler bracket	45	4.5	32.5
Fuel injection pipe flare nut (fuel injection nozzle side)	30	3.0	21.5
Fuel injection pipe flare nut (fuel injection pump side)	27	2.7	19.5
Fuel injection nozzle	64	6.4	46.5
Fuel injection nozzle nut	29	2.9	21.0
Nozzle holder body	37	3.7	27.0
Fuel injection pump pulley locknut	65	6.5	47.0
TP sensor mounting screw	2	0.2	1.5
Glow plug	17	1.7	12.5
Fuel temperature sensor	22	2.2	16.0
ECT sensor	27	2.7	19.5
VSS	9	0.9	6.5

## SPECIAL TOOLS

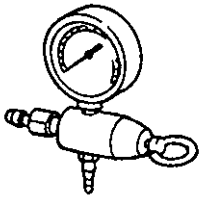
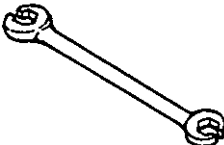
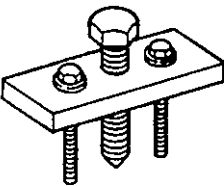
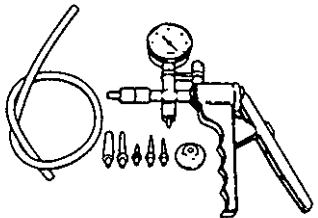
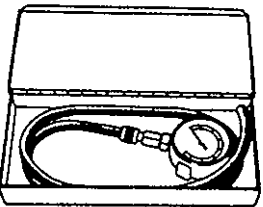
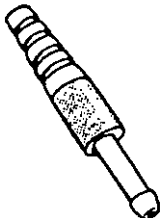
 <p>09918-18110 Regulator assembly</p>	 <p>09950-76010 Flare nut wrench (17 - 19 mm)</p>	 <p>09944-36011 Steering wheel remover</p>	 <p>09917-47910 Vacuum pump gauge</p>
 <p>09915-67310 Vacuum gauge</p>	 <p>09918-08210 Vacuum gauge hose joint</p>		

## SECTION 6G

# CRANKING SYSTEM

## (2.2 kW Reduction Type)

**NOTE:**

For the descriptions (items) not found in this section, refer to the same section of the Service Manual mentioned in FOREWORD of this manual.

## CONTENTS

<b>GENERAL DESCRIPTION</b> .....	6G- 2
Cranking Circuit .....	6G- 2
Starting Motor Circuit .....	6G- 2
Starting Motor .....	6G- 3
<b>DIAGNOSIS</b> .....	6G- 4
<b>UNIT REPAIR OVERHAUL</b> .....	6G- 5
Dismounting and Remounting .....	6G- 5
Disassembly and Reassembly .....	6G- 5
Inspection .....	6G- 6
Performance Test .....	6G- 9
Pull-in test .....	6G- 9
Hold-in test .....	6G- 9
Pinion clearance test .....	6G- 9
Plunger and pinion return test .....	6G-10
No-load performance test .....	6G-10
<b>SPECIFICATIONS</b> .....	6G-10
<b>REQUIRED SERVICE MATERIAL</b> .....	6G-11
<b>TIGHTENING TORQUE SPECIFICATIONS</b> .....	6G-11
<b>SPECIAL TOOL</b> .....	6G-11

## GENERAL DESCRIPTION

### CRANKING CIRCUIT

The cranking circuit consists of the battery, starting motor, ignition switch, and related electrical wiring. These components are connected electrically.

Only the starting motor will be covered in this section.

### STARTING MOTOR CIRCUIT

- The magnetic switch coils are magnetized when the ignition switch is closed.
- The resulting plunger and pinion drive lever movement causes the pinion to engage the engine flywheel gear and the magnetic switch main contacts to close, and cranking takes place.
- When the engine starts, the pinion over-running clutch protects the armature from excessive speed until the switch is opened, at which time the return spring causes the pinion to disengage.

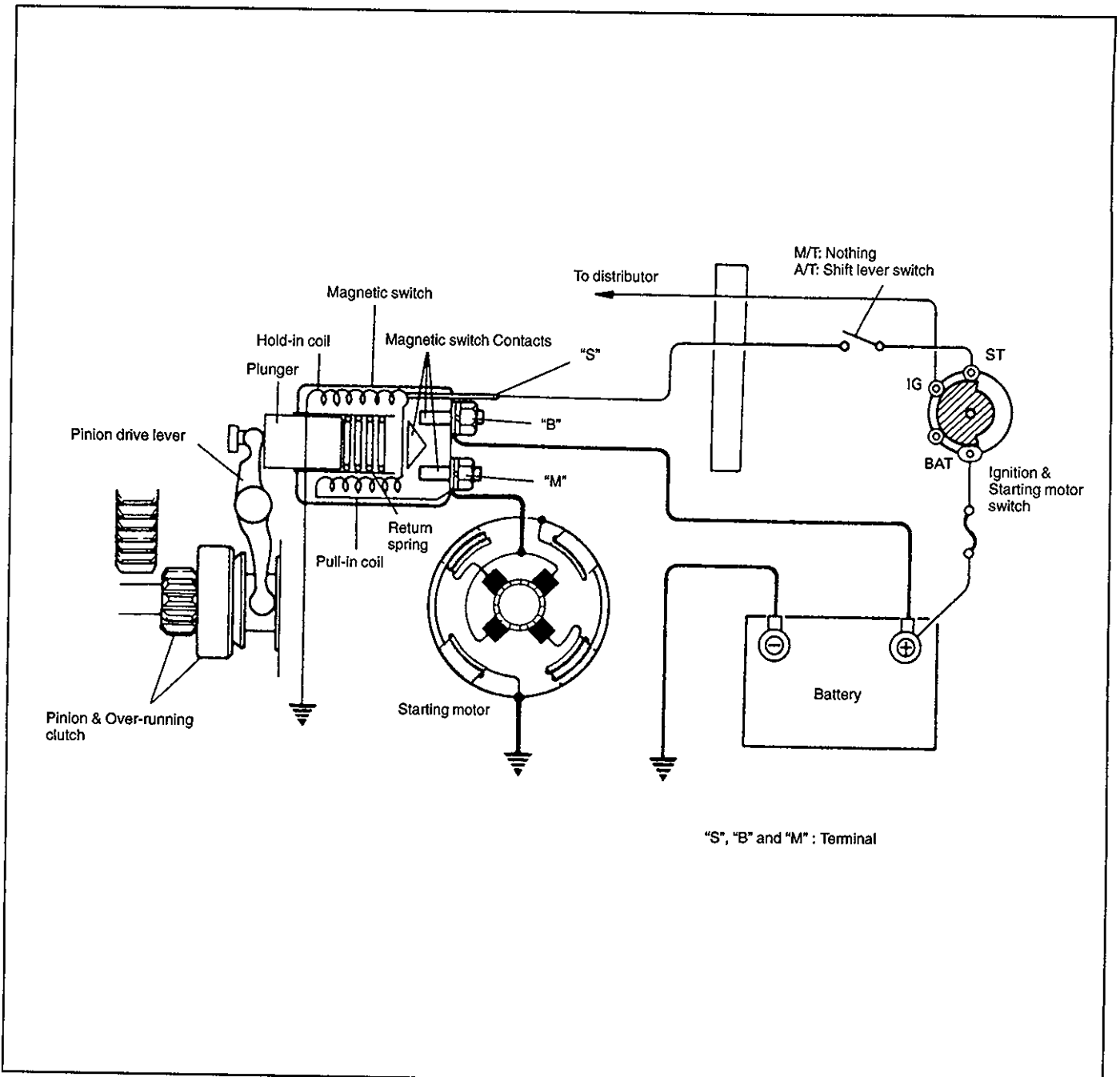

## STARTING MOTOR

The starting motor consists of parts shown in below.

The magnetic switch assembly and parts in the starting motor are enclosed in the housings so that they will be protected against possible dirt and water splash.

### NOTE:

- Make sure to apply grease before assembly where so indicated "A" in the figure below.
- Spare parts have been lubricated.

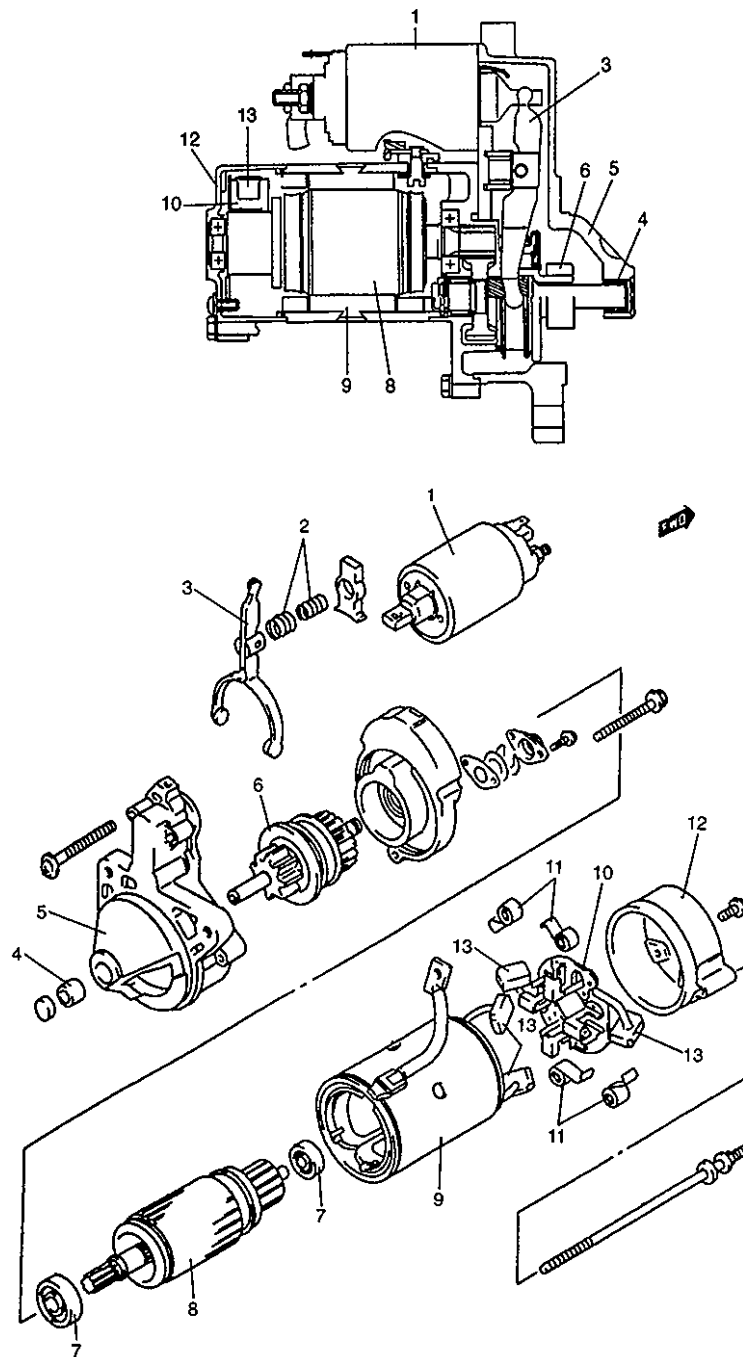

"A": Apply grease (99000-25010)

1. Magnetic switch
2. Spring
3. Lever
4. Bush
5. Front housing

6. Pinion gear and assembly
7. Bearing
8. Armature
9. Yoke
10. Brush holder

11. Brush spring
12. Rear bracket
13. Brush

## DIAGNOSIS

**NOTE:**  
For the conditions not found in this table below, refer to the Section 6G of the Service Manual mentioned in FOREWORD of this manual.

Condition	Possible Cause	Correction
<b>Motor not running</b>	<ul style="list-style-type: none"> <li>● Burnt commutator</li> <li>● Poor grounding of field coil</li> <li>● Layer short-circuit of armature</li> <li>● Crankshaft rotation obstructed</li> </ul>	Replace armature. Repair. Replace. Repair.
<b>Starting motor running but too slow (small torque)</b>	<p><b>If battery and wiring are satisfactory, inspect starting motor</b></p> <ul style="list-style-type: none"> <li>● Insufficient contact of magnetic switch main contacts</li> <li>● Layer short-circuit of armature</li> <li>● Disconnected, burnt or worn commutator</li> <li>● Poor grounding of field coil</li> <li>● Worn brushes</li> <li>● Weakened brush springs</li> <li>● Burnt or abnormally worn end bush</li> </ul>	Replace magnetic switch. Replace. Repair commutator or replace armature. Repair. Replace brush. Replace spring. Replace bush.

## UNIT REPAIR OVERHAUL

### DISMOUNTING AND REMOUNTING

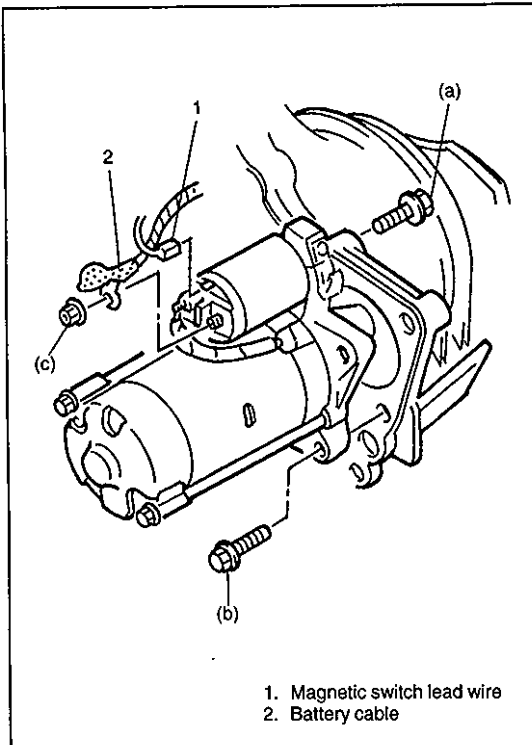

- 1) Disconnect negative battery lead at battery.
- 2) Disconnect magnetic switch lead wire ("S" terminal) and battery cable from starting motor terminal ("B" terminal).
- 3) Remove starting motor mount bolts and remove starting motor.
- 4) To install, reverse the above procedure.

#### Tightening torque

- (a): 45 N·m (4.5 kg-m, 32.5 lb-ft)  
 (b): 22 N·m (2.2 kg-m, 16 lb-ft)  
 (c): 11 N·m (1.1 kg-m, 8 lb-ft)

## DISASSEMBLY AND REASSEMBLY

#### NOTE:

- Disassemble in order shown in figure.
- For reassembly, reverse disassembly procedure.
- Tightening bolt and nut to specified torque.

#### Tightening torque

- (a): 11 N·m (1.1 kg-m, 8 lb-ft)  
 (b): 6 N·m (0.6 kg-m, 4.5 lb-ft)

- Upon completely of reassembly, carry out "Performance Test" later in this section.

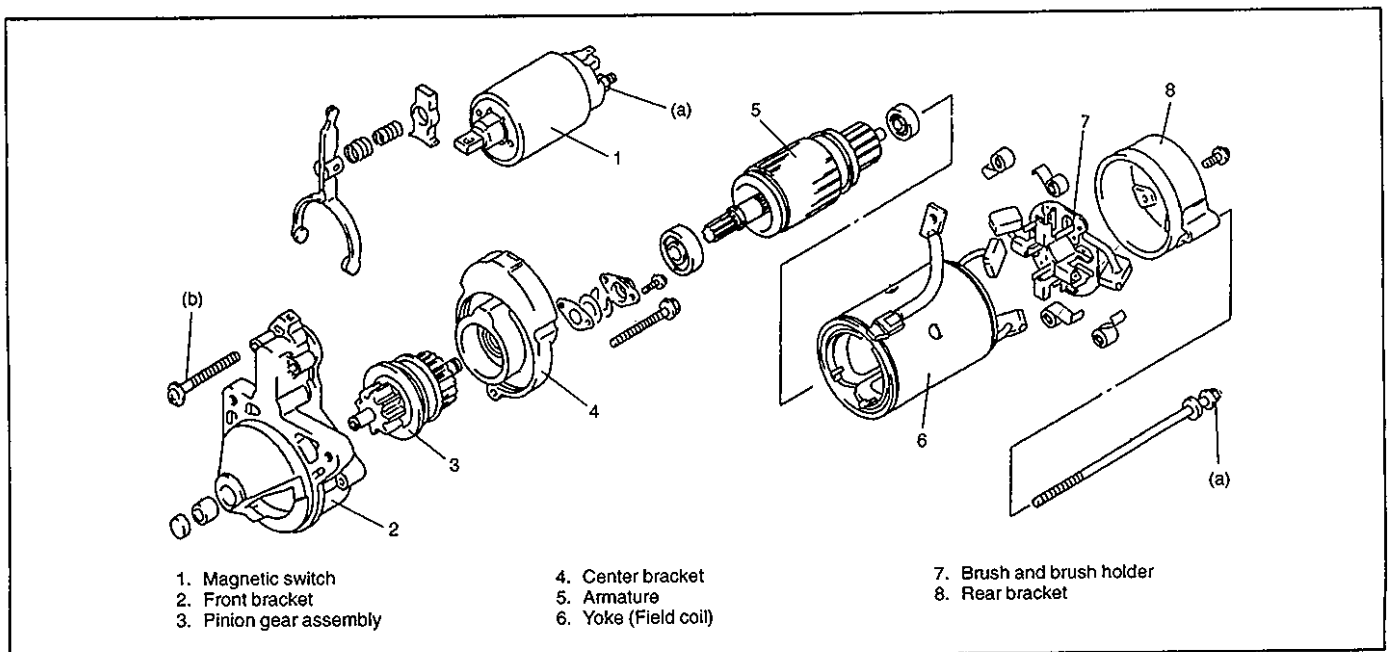

M/T vehicle except for cold area

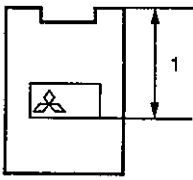

M/T vehicle for cold area and A/T vehicle

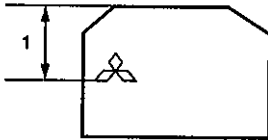

1. Wear limit

## INSPECTION

### 1. BRUSH

- Check brushes for wear.  
Measure length of brushes and if below limit, replace brush.

#### Brush length

Standard	18.0 mm (0.71 in.)
Limit	11.0 mm (0.43 in.)

- Install brushes to each brush holder and check for smooth movement.

### 2. SPRING

Inspect brush springs for wear, damage or other abnormal conditions. Replace if necessary.

#### Brush spring tension

Standard	3.4 kg (7.7 lb)
Limit	2.0 kg (4.4 lb)

### 3. BRUSH HOLDER

- Check movement of brush in brush holder. If brush movement within brush holder is sluggish, check brush holder for distortion and sliding faces for contamination. Clean or correct as necessary.
- Check for continuity between insulated brush holder and brush holder plate. Replace brush and brush holder if there is continuity.

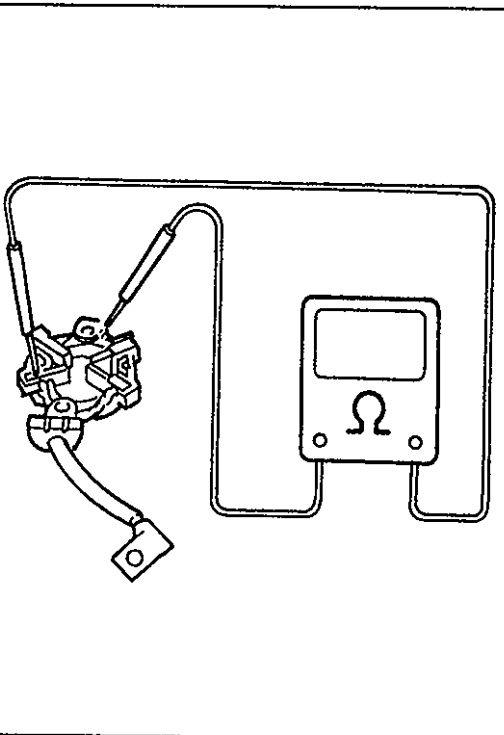
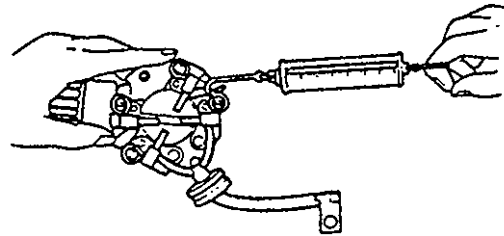

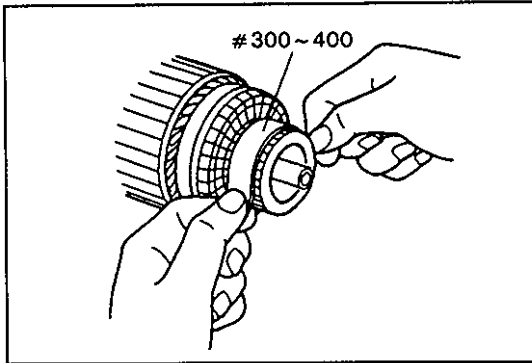

#### 4. ARMATURE

- Inspect commutator for dirt or burn. Correct with sandpaper or lathe, if necessary.

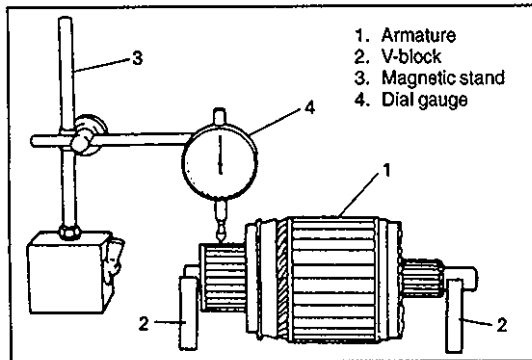

- Check commutator for uneven wear with armature supported on V-blocks. If deflection of dial gauge pointer exceeds limit, repair or replace.

**NOTE:**

**Below specification presupposes that armature is free from bend. Bent armature must be replaced.**

**Commutator out of round**

**Standard : 0.05 mm (0.002 in.) or less**

**Limit : 0.1 mm (0.004 in.)**

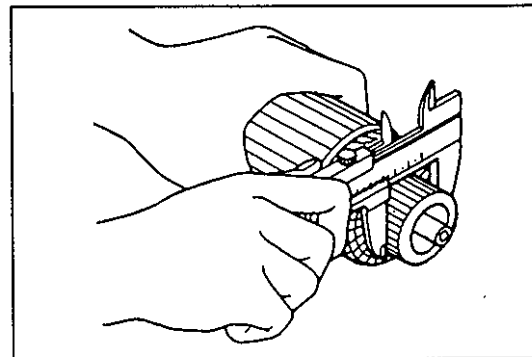

- Inspect commutator for wear. If diameter is below limit, replace armature.

**Commutator outside diameter**

**Limit : 31.4 mm (1.24 in.)**

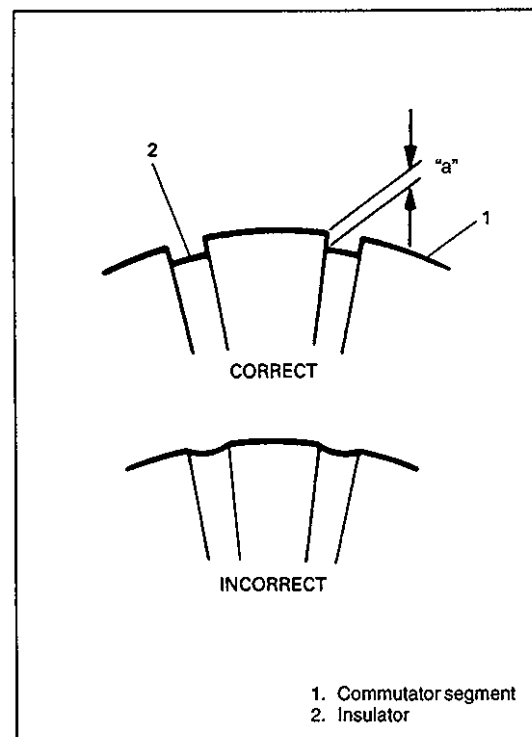

- Inspect commutator for insulator depth. Correct or replace if below limit.

**Commutator insulator depth "a"**

**Standard : 0.5 – 0.8 mm (0.02 – 0.031 in.)**

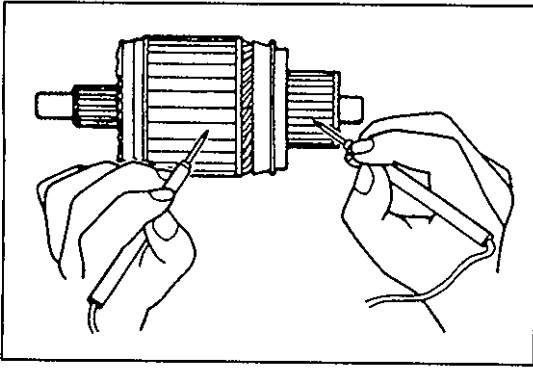

● **Ground Test**

Check commutator and armature core. If there is continuity, armature is grounded and must be replaced.

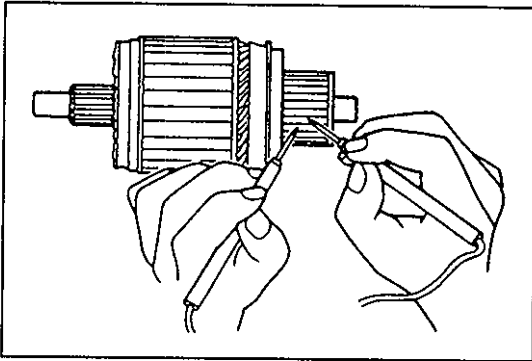

● **Open Circuit Test**

Check for continuity between segments. If there is no continuity at any test point, there is an open circuit and armature must be replaced.

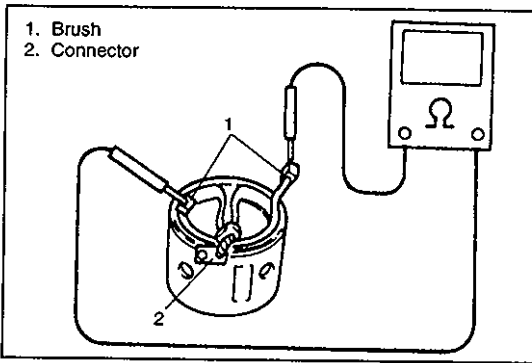

**5. FIELD COIL**

● Check for continuity between brushes and between connector and brush. Replace field coil if there is continuity.

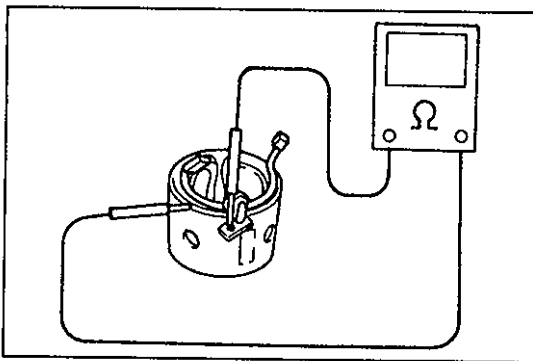

● Check for continuity between connector and yoke. Replace field coil if there is continuity.

## PERFORMANCE TEST

### CAUTION:

Each test must be performed within 3 – 5 seconds to avoid coil from burning.

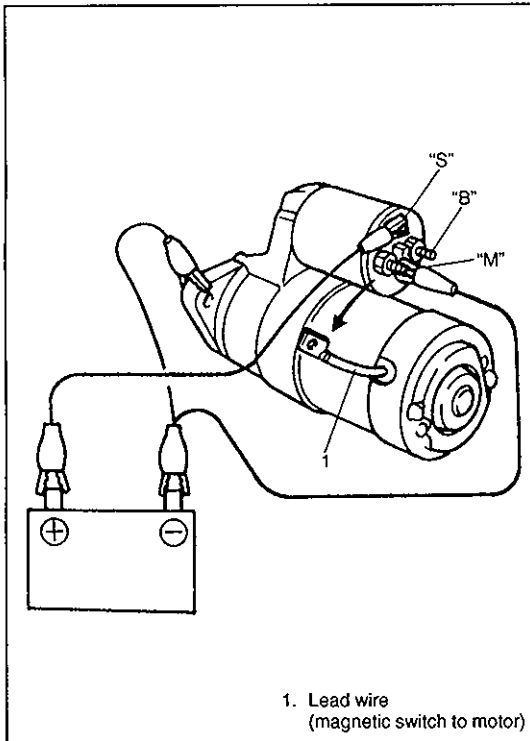

### 1) Pull-In Test

Connect battery to magnetic switch as shown.  
Check that plunger and pinion move outward.  
If plunger and pinion don't move, replace magnetic switch.

### NOTE:

Before testing, disconnect lead wire from terminal "M".

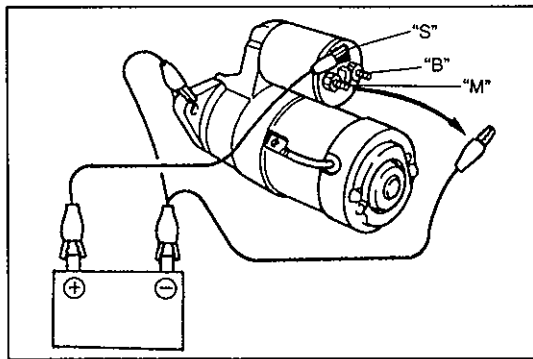

### 2) Hold-In Test

While connected as above with plunger out, disconnect negative lead from terminal "M".  
Check that plunger and pinion remain out.  
If plunger and pinion return inward, replace magnetic switch.

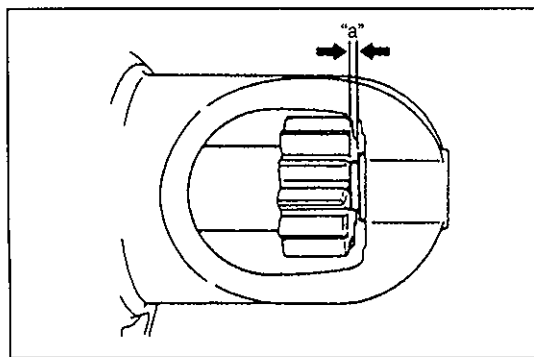

### 3) Pinion Clearance Test

a) Carry out "Pull-In Test" and hold pinion in projected position.  
Measure clearance between stopper and pinion gear.

**Pinion clearance "a": 0.5 – 2.0 mm (0.02 – 0.08 in.)**

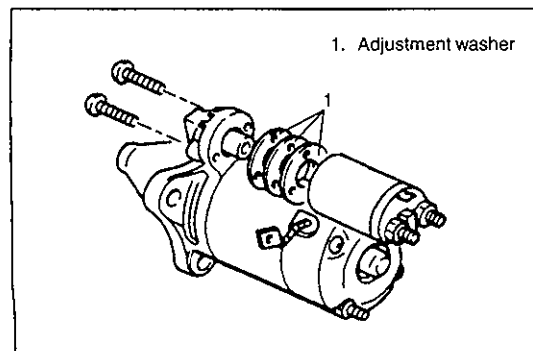

b) If not within specification, adjust by adding/subtracting adjustment washers at magnetic switch mounting surface. Add washers to reduce clearance.

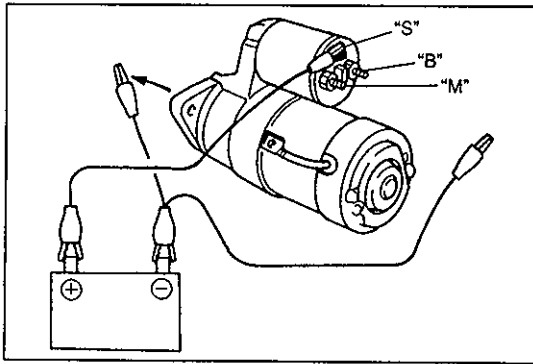

#### 4) Plunger and Pinion Return Test

Disconnect negative lead from switch body.

Check that plunger and pinion return inward.

If plunger and pinion don't return, disassemble and inspect starting motor.

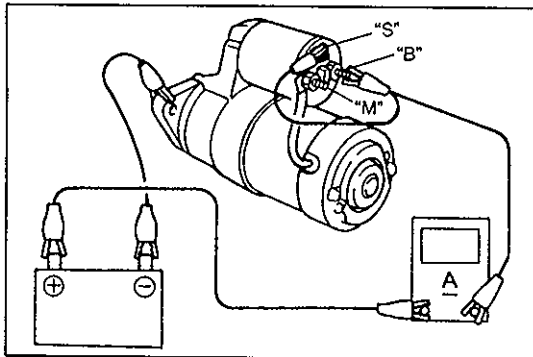

#### 5) No-Load Performance Test

a) Connect battery and ammeter to starter as shown.

b) Check that starter rotates smoothly and steadily with pinion moving out. Check that ammeter indicates specified current.

**Specified current: 130A MAX. at 11V**

**NOTE:**

Use wires as thick as possible and tighten each terminal fully.

## SPECIFICATIONS

			2.2 kW type
Voltage			12 volts
Output			2.2 kW
Rating			30 seconds
Direction of rotation			Clockwise as viewed from pinion side
Brush length			11.0 mm (0.43 in.)
Number of pinion teeth			8
	Performance	Condition	Guarantee
Around at 20 °C (68 °F)	No load characteristic	11.0 V	130 A maximum 4,500 rpm minimum
	Load characteristic	7.7 V 400 A	9.7 N·m (0.97 kg-m, 7.02 lb-ft) minimum 1,550 rpm minimum
	Locked characteristic	3.0 V	1020 A maximum 30 N·m (3.0 kg-m, 21.7 lb-ft) minimum
	Magnetic switch operating voltage		8 volts maximum

## REQUIRED SERVICE MATERIAL

MATERIAL	RECOMMENDED SUZUKI PRODUCT	USE
Lithium grease	SUZUKI SUPER GREASE A (99000-25010)	<ul style="list-style-type: none"> <li>● Front and rear bush</li> <li>● Plunger</li> <li>● Pinion drive lever</li> <li>● Internal gear</li> <li>● Planetary carrier shaft</li> <li>● Planetary gear</li> <li>● Ball</li> </ul>

## TIGHTENING TORQUE SPECIFICATIONS

Fastening parts	Tightening torque		
	N·m	kg-m	lb-ft
Starting motor mounting bolt (Refer to page 6G-5.)	45	4.5	32.5
	22	2.2	16
"B" terminal nut	11	1.1	8
Magnetic switch screw	6	0.6	4.5
Starting motor housing screw	11	1.1	8

## SPECIAL TOOL

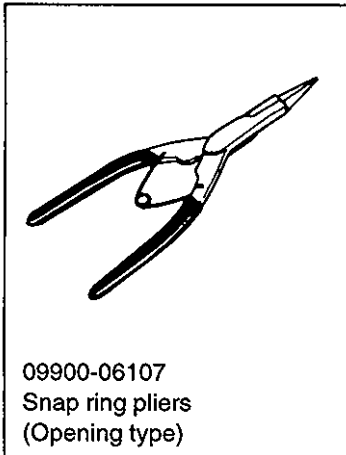

## SECTION 6H

# CHARGING SYSTEM

**WARNING:**

**For vehicles equipped with Supplemental Restraint (Air Bag) System**

- **Service on and around the air bag system components or wiring must be performed only by an authorized SUZUKI dealer. Refer to “Air Bag System Components and Wiring Location View” under “General Description” in air bag system section in order to confirm whether you are performing service on or near the air bag system components or wiring. Please observe all WARNINGS and “Service Precautions” under “On-Vehicle Service” in air bag system section before performing service on or around the air bag system components or wiring. Failure to follow WARNINGS could result in unintentional activation of the system or could render the system inoperative. Either of these two conditions may result in severe injury.**
- **Technical service work must be started at least 90 seconds after the ignition switch is turned to the “LOCK” position and the negative cable is disconnected from the battery. Otherwise, the system may be activated by reserve energy in the Sensing and Diagnostic Module (SDM).**

6H

## CONTENTS

<b>GENERAL DESCRIPTION</b> .....	6H- 2
GENERATOR .....	6H- 2
<b>DIAGNOSIS</b> .....	6H- 3
GENERATOR .....	6H- 3
No-load Check .....	6H- 3
Load Check .....	6H- 4
<b>ON-VEHICLE SERVICE</b> .....	6H- 4
GENERATOR .....	6H- 4
On-vehicle Service .....	6H- 4
Fan (generator) Belt .....	6H- 5
Vacuum Pump .....	6H- 6
<b>UNIT REPAIR OVERHAUL</b> .....	6H- 6
GENERATOR .....	6H- 6
Dismounting and Remounting .....	6H- 6
Disassembly and Reassembly .....	6H- 7
Inspection .....	6H- 8
<b>SPECIFICATIONS</b> .....	6H-10
BATTERY .....	6H-10
GENERATOR .....	6H-10
<b>TIGHTENING TORQUE SPECIFICATIONS</b> .....	6H-10
<b>SPECIAL TOOLS</b> .....	6H-11

# GENERAL DESCRIPTION

## GENERATOR

The generator is a small and high performance type with an IC regulator incorporated. The internal components are connected electrically as shown below figure.

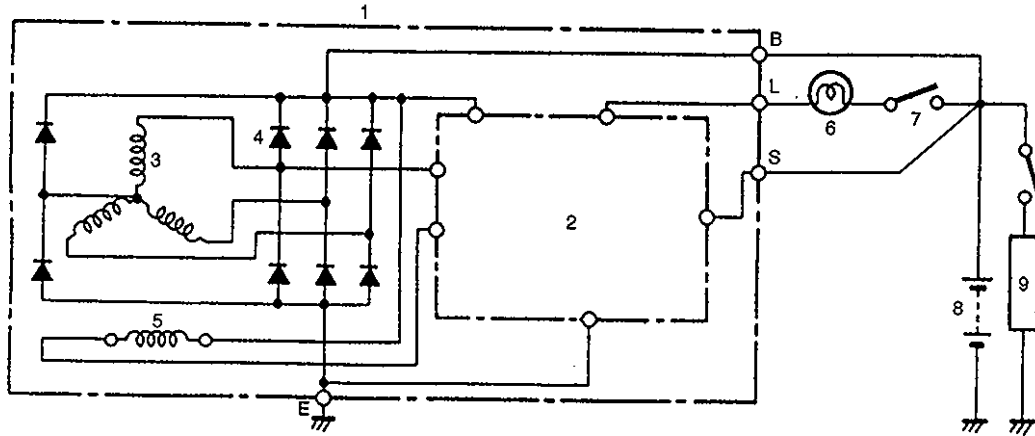

- |                                   |                            |                |                   |
|-----------------------------------|----------------------------|----------------|-------------------|
| 1. Generator with regulator ass'y | 4. Diode                   | 7. Main switch | B, L, S: Terminal |
| 2. I.C. regulator                 | 5. Field coil (rotor coil) | 8. Battery     |                   |
| 3. Stator coil                    | 6. Charge indicator light  | 9. Load        |                   |

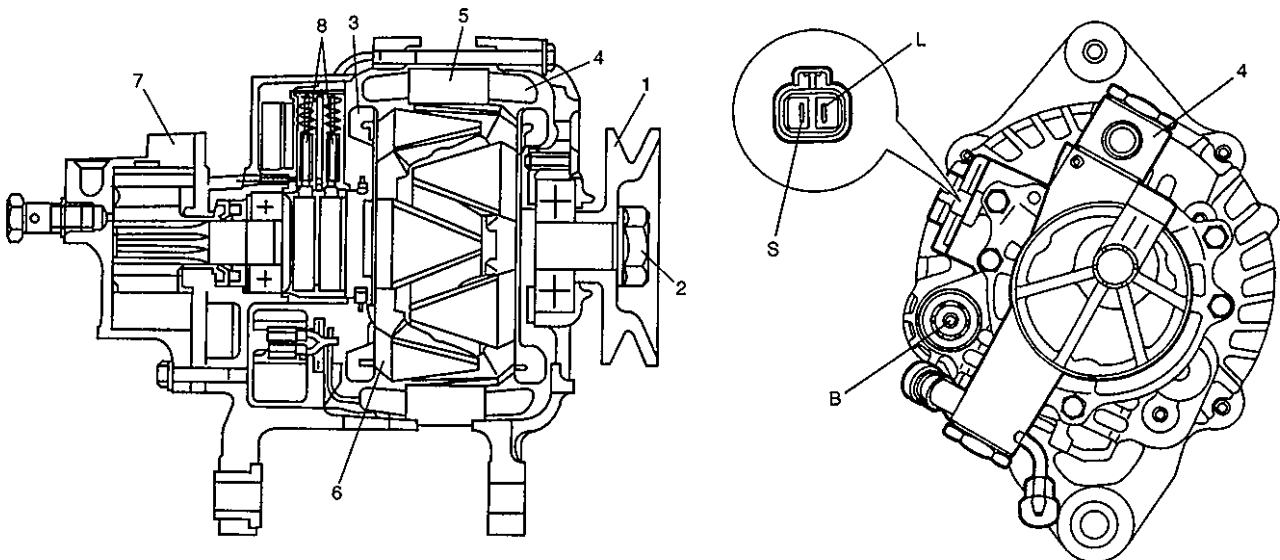

- |                |                |                   |
|----------------|----------------|-------------------|
| 1. Pulley      | 5. Stator core | B, L, S: Terminal |
| 2. Pulley nut  | 6. Rotor       |                   |
| 3. Rotor fan   | 7. Vacuum pump |                   |
| 4. Stator coil | 8. Brush       |                   |

## DIAGNOSIS

### GENERATOR

#### NO-LOAD CHECK

Following procedure also applies to vehicles with voltmeter and ammeter.

- 1) Check fan (generator) belt for proper tension.
- 2) If battery defect is suspected, refer to BATTERY section.
- 3) Inspect wiring for defects. Check all connections for tightness and cleanliness, battery cable connections at battery, starting motor and ignition ground cable.
- 4) Connect voltmeter and ammeter as shown in the figure.

#### Voltmeter

Set between generator "B" terminal and ground.

#### Ammeter

Set between generator "B" terminal and battery (+) terminal.

#### NOTE:

**Use fully charged battery.**

- 5) Measure current and voltage.
- 6) Run engine from idling up to 2,000 rpm and read meters.

#### NOTE:

**Turn off switches of all accessories (wiper, heater etc.).**

**Standard current: 10 A maximum**

**Standard voltage: 14.1 – 14.7 V (at 20°C, 68°F)**

#### NOTE:

**Consideration should be taken that voltage will differ somewhat with regulator case temperature as shown in left figure.**

#### Higher Voltage

If voltage is higher than standard value, check ground of brushes.

If brushes are not grounded, replace IC regulator.

#### Lower Voltage

If voltage is below or in standard value, check rotor, stator, rectifier, brush, IC regulator or etc.

Ammeter between generator "B" terminal and battery (+) terminal

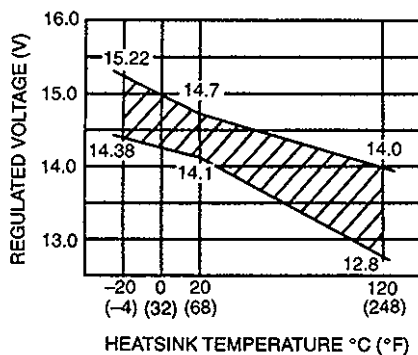
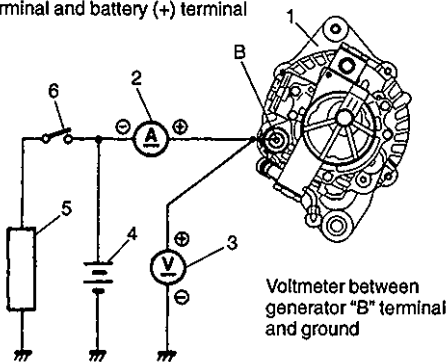

- |              |            |
|--------------|------------|
| 1. Generator | 4. Battery |
| 2. Ammeter   | 5. Load    |
| 3. Voltmeter | 6. Switch  |

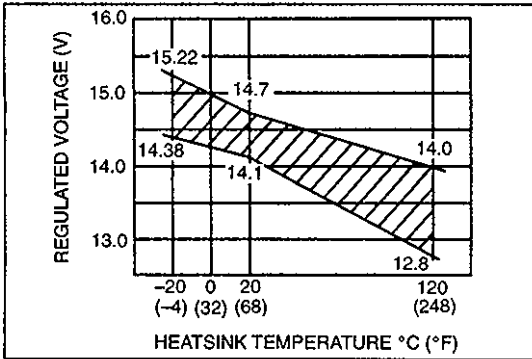

### LOAD CHECK

- 1) In the same way as in "No-load Check", connect voltmeter and ammeter.
- 2) Run engine speed to 2,000 rpm and turn on headlight, blower fan motor and rear defogger.
- 3) Measure current value and if measured value is less than that obtained in "No-load Check", replace generator.

## ON-VEHICLE SERVICE

### GENERATOR

#### ON-VEHICLE INSPECTION

- 1) Verify that battery is fully charged.
- 2) Verify that fan (generator) belt deflection and tension are correct. Refer to "Fan (Generator) Belt" later in this section.
- 3) Verify that charge warning light comes ON when ignition switch is turned to ON. (NOT run engine)  
If not, check charge warning light and wiring harness between battery, charge warning light, and generator.
- 4) Start engine and verify that charge warning light goes out.  
If not, turn all electrical loads OFF and measure voltage at each generator terminal.

Terminal	Voltage (V) at 20°C (68°F)	
	at ignition sw ON	at idling engine
B	V <sub>B</sub>	14.1 – 14.7
L	Approx. 1	V <sub>B</sub>
S	V <sub>B</sub>	14.1 – 14.7

V<sub>B</sub> : Battery positive terminal

If not as specified above, replace generator.

If voltage is correct, check for open or short circuit in wiring harness.

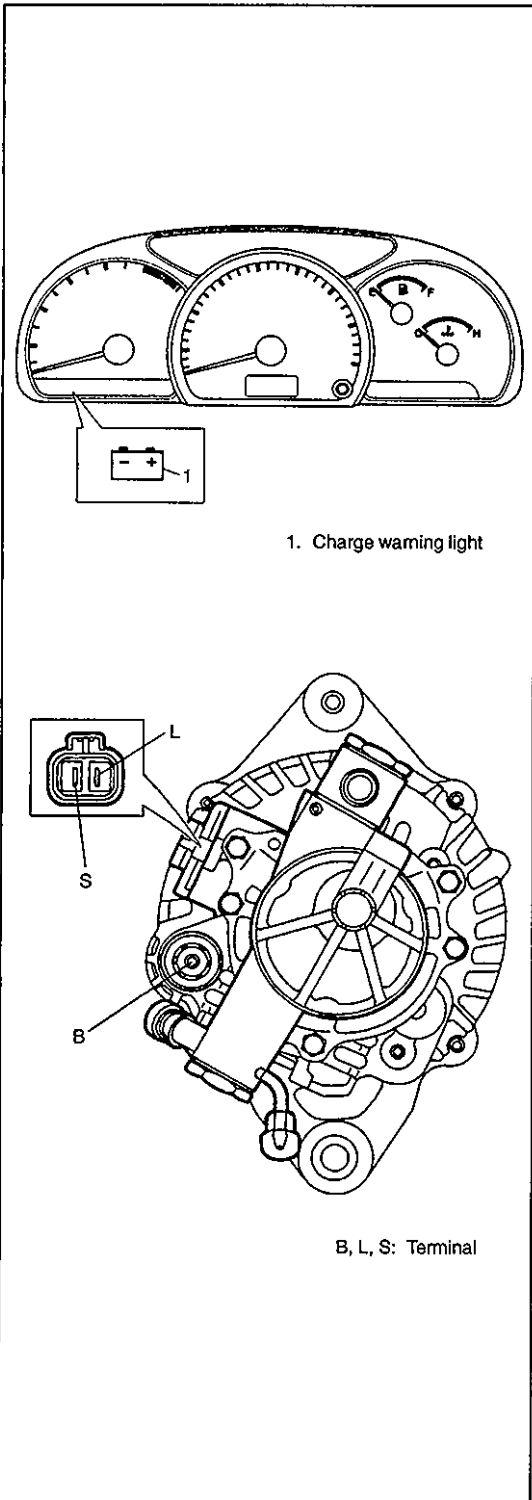

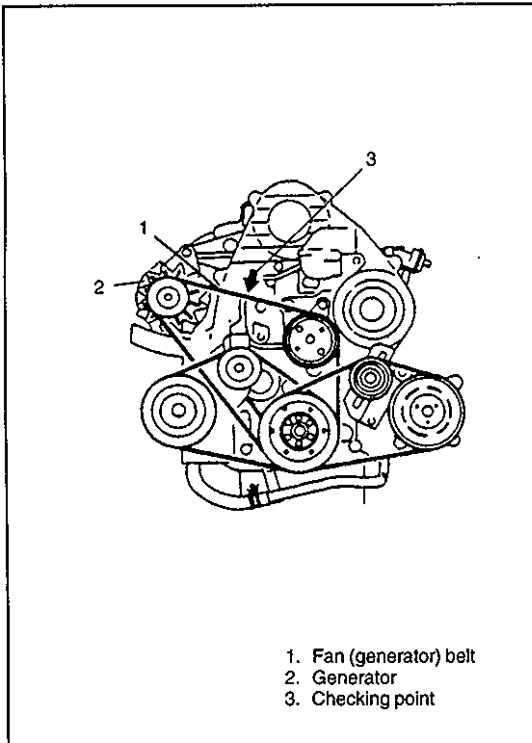

## FAN (GENERATOR) BELT INSPECTION AND ADJUSTMENT

- Verify that belt engages with pulley groove correctly.
- Visually check for wear and damage on belt and pulley contact surface and damage on pulley.
- Measure belt deflection by applying force of 98 N (10 kg, 22 lb) on belt between pulleys as shown.

### Belt tension specification:

15 — 17 mm (0.59 — 0.67 in.) as deflection  
(when inspection)

15 — 16 mm (0.59 — 0.63 in.) as deflection  
(when adjustment)

8 — 10 mm (0.31 — 0.39 in.) as deflection  
(After adjustment of new belt)

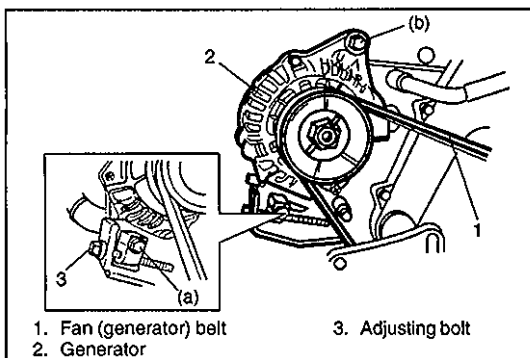

If the deflection is not within specification, adjust by loosening fan (generator) belt adjusting bolt.

### Tightening Torque

(a): 23 N·m (2.3 kg-m, 16 lb-ft)

(b): 45 N·m (4.5 kg-m, 32.5 lb-ft)

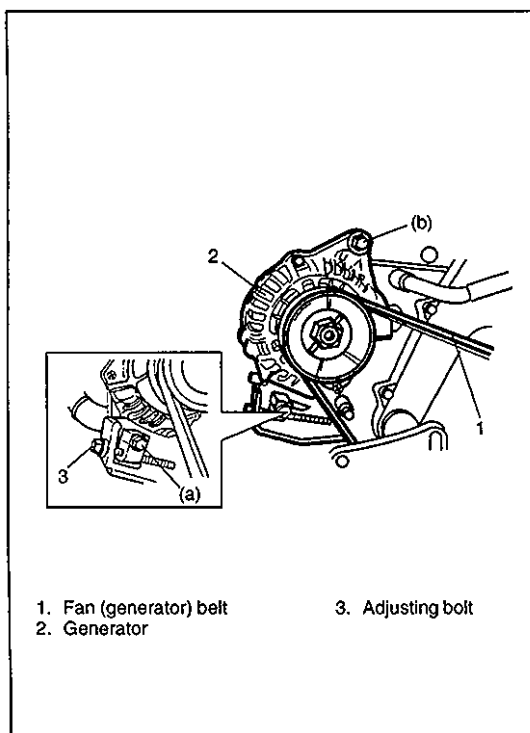

## REMOVAL

### WARNING:

Disconnect negative cable at battery before removing and installing fan (generator) belt.

- 1) Loosen fan (generator) belt adjusting bolt.
- 2) Remove fan (generator) belt.

## INSTALLATION

Reverse removal procedure, noting following points.

- Make sure that the belt fits each pulley's groove properly.
- After installing fan (generator) belt, perform checks described above.
- Tightening bolt to specified torque.

### Tightening Torque

(a): 23 N·m (2.3 kg-m, 16 lb-ft)

(b): 45 N·m (4.5 kg-m, 32.5 lb-ft)

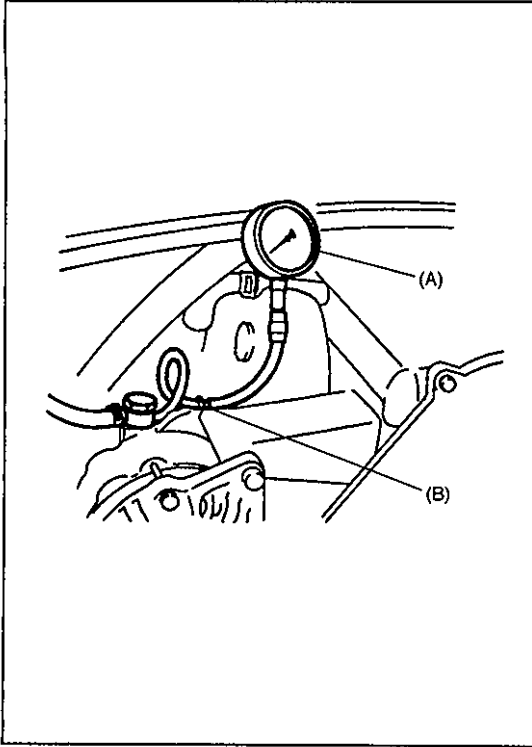

## VACUUM PUMP

### ON-VEHICLE INSPECTION

Install a vacuum gauge to the vacuum circuit as shown in the figure and measure vacuum.

**59 kPa (440 mmHg) or more (at engine speed 1,500 rpm)**

**77 kPa (580 mmHg) or more (at engine speed 3,000 rpm)**

### Special Tool

(A): 09915-67310

(B): 09918-08210

## UNIT REPAIR OVERHAUL GENERATOR

### DISMOUNTING AND REMOUNTING

- Dismounting in order shown in figure.
- For remounting, reverse dismounting procedure.
- Tightening bolt and nut to specified torque.

### Tightening Torque

(a): 8 N·m (0.8 kg-m, 6 lb-ft)

(b): 45 N·m (4.5 kg-m, 32.5 lb-ft)

(c): 23 N·m (2.3 kg-m, 16.5 lb-ft)

(d): 10 N·m (1.0 kg-m, 7.5 lb-ft)

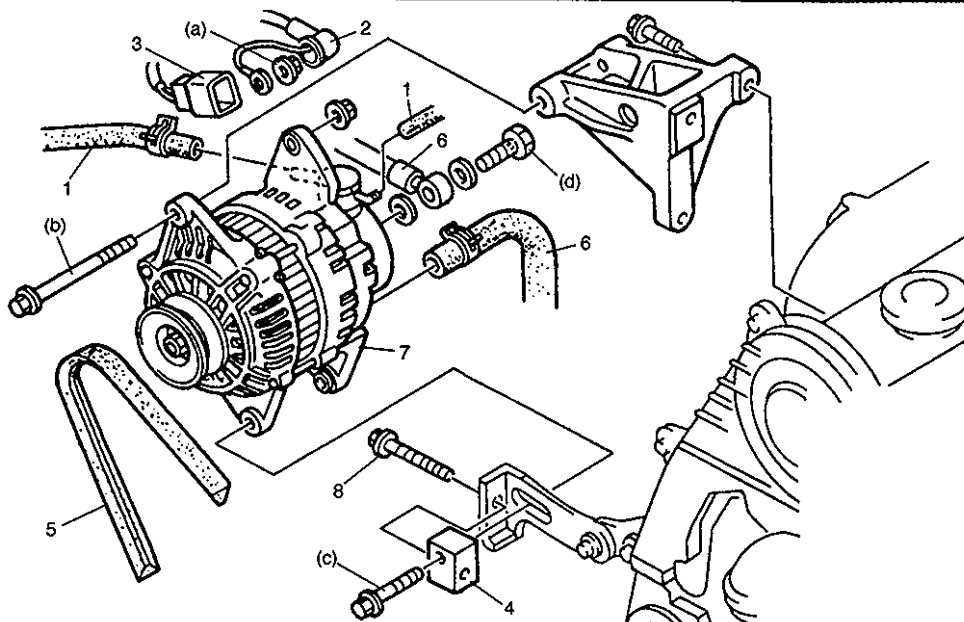

1. Vacuum hose
2. Terminal "B" cable
3. Connector
4. Belt tensioner
5. Fan (generator) belt
6. Oil hose
7. Generator
8. Adjusting bolt

## DISASSEMBLY AND REASSEMBLY

- Disassembly in order shown in figure below and note following precautions.
- For reassembly, reverse disassembly procedure.
- Tightening bolt and nut to specified torque.

### Tightening Torque

(a): 110 N·m (11 kg-m, 79.5 lb-ft)

(b): 5 N·m (0.5 kg-m, 4 lb-ft)

(c): 8 N·m (0.8 kg-m, 6 lb-ft)

(d): 33 N·m (3.3 kg-m, 24 lb-ft)

(e): 23 Nm (2.3 kg-m, 17 lb-ft)

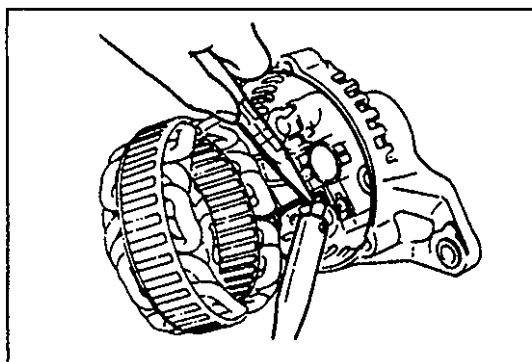
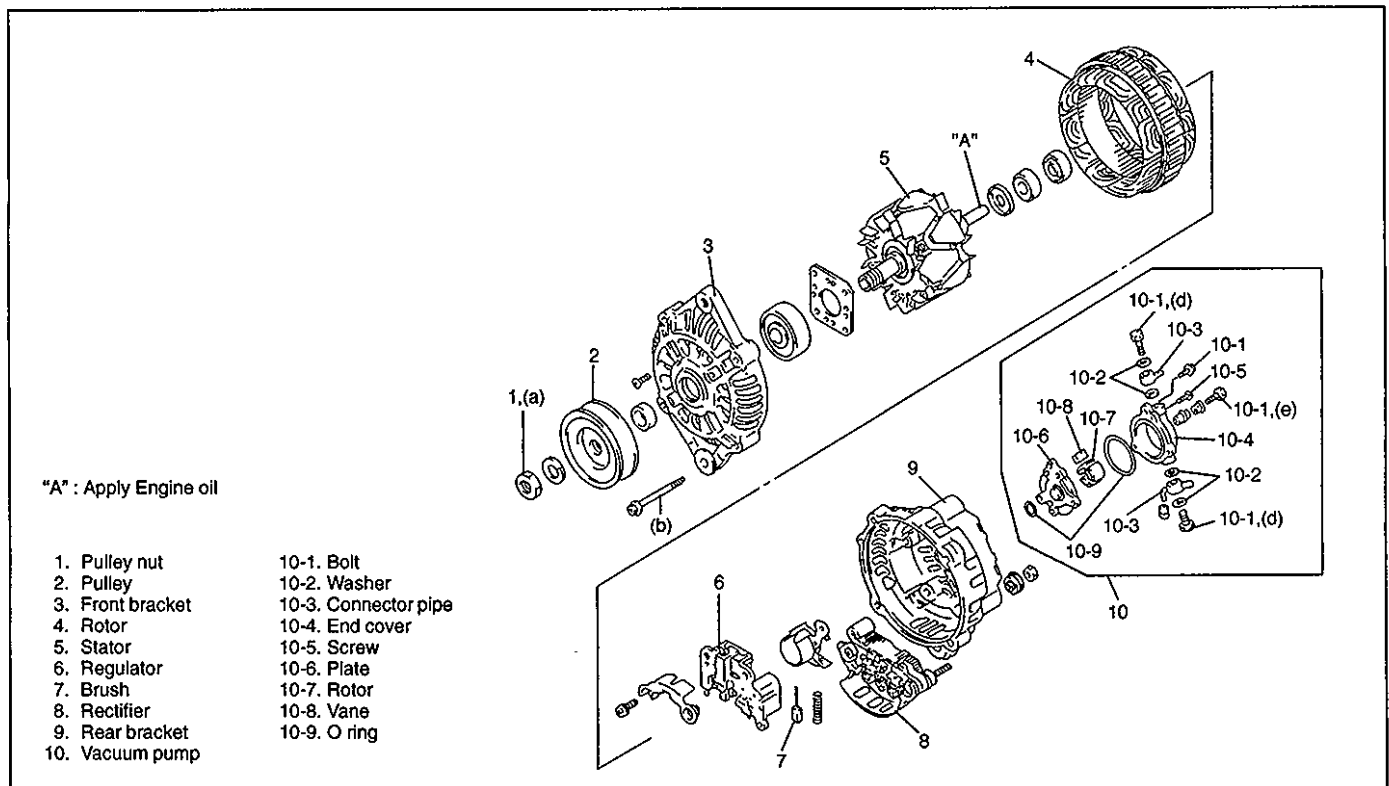

- When removing stator lead wire from rear bracket, carry out soldering quickly.

#### CAUTION:

Overheating can damage semiconductor components such as regulator and rectifier.

#### NOTE:

Hold lead wire with pliers during soldering to prevent applying heat to rectifier.

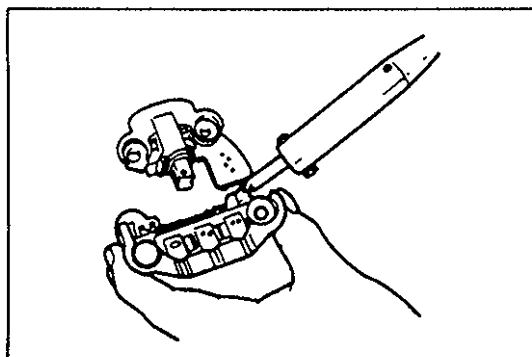

- When removing brush holder and rectifier from regulator assembly, carry out soldering quickly.

#### CAUTION:

Overheating can damage semiconductor components such as regulator and rectifier.

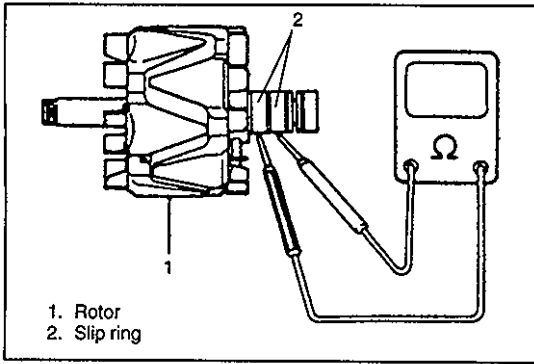

## INSPECTION

### Rotor

- 1) Using ohmmeter, check for continuity between slip rings of rotor. If there is no continuity, replace rotor.

**Standard resistance: 2.5 – 3.1  $\Omega$**

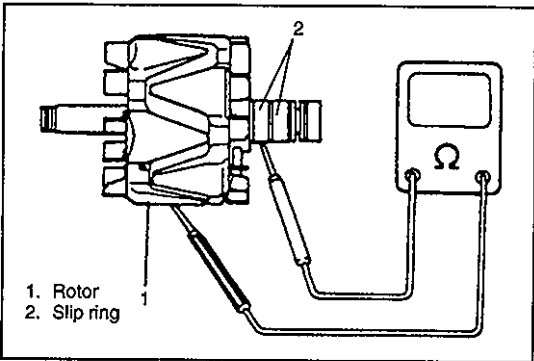

- 2) Using ohmmeter, check that there is no continuity between slip ring and rotor core. If there is continuity, replace rotor.
- 3) Check slip rings for roughness or scoring. If rough or scored, replace rotor.

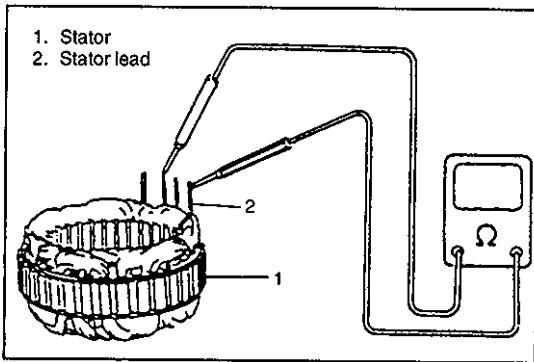

### Stator

- 1) Using ohmmeter, check all leads for continuity. If there is no continuity, replace stator.

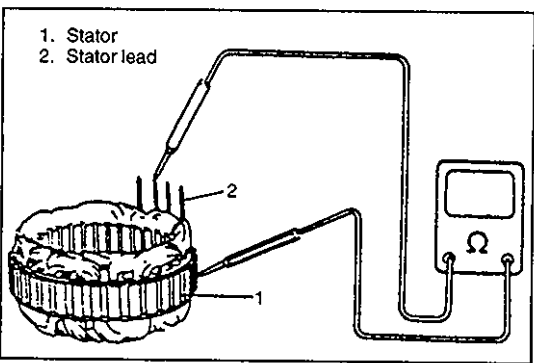

- 2) Using ohmmeter, check that there is no continuity between coil leads and stator core. If there is continuity, replace stator.

### NOTE:

**Painted part of core (green) is insulated.**

**When checking continuity at core, apply tester lead to non-coated metal part.**

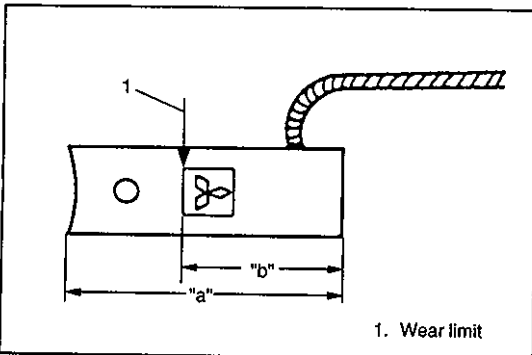

### Brush

- 1) Check each brush for wear by measuring its length. If brush is found worn down to service limit, replace brush.

**Standard "a" : 16.5 mm (0.65 in.)**

**Service limit "b" : 8 mm (0.31 in.)**

### NOTE:

**If replacing brush, remove wire from brush by melting solder.**

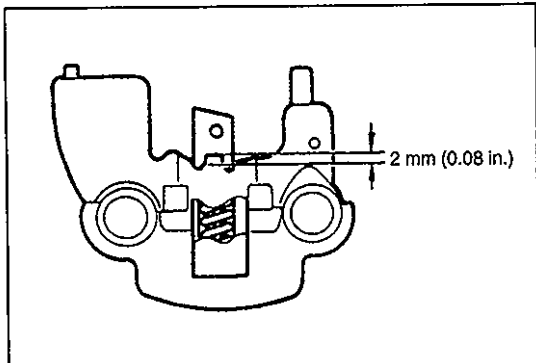

2) In When installing new brush, insert it into the holder approx. 2 mm (0.08 in.) by pulling lead wire, and solder.

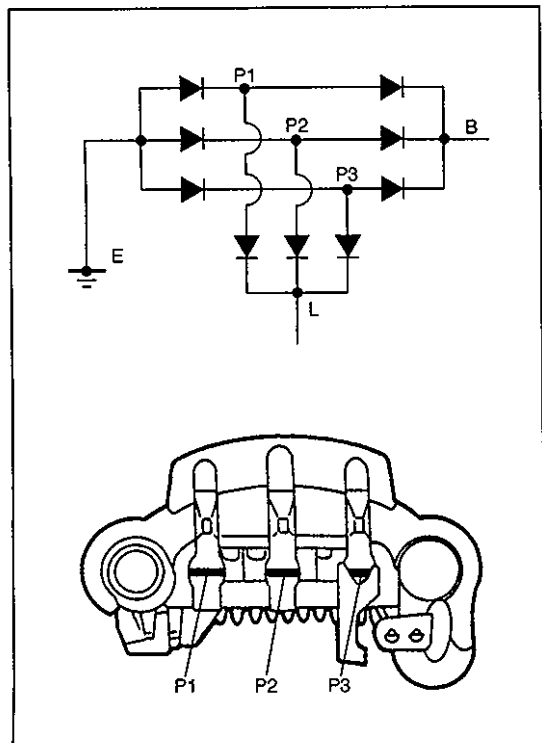

**Rectifier**

Check continuity of rectifier by using tester as follows.

Tester (-) terminal	Tester (+) terminal	Continuity
E	P1, P2, P3	Continuity
B		No-continuity
L		No-continuity
P1, P2, P3	E	No-continuity
	B	Continuity
	L	Continuity

If not as specified, replace rectifier.

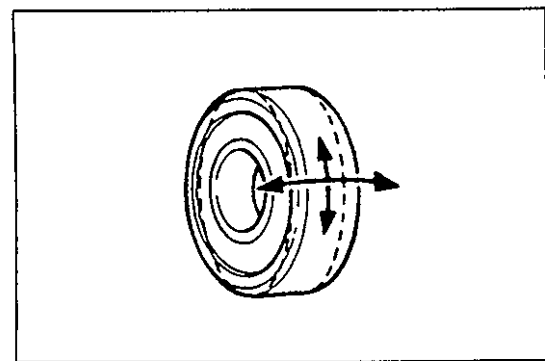

**Front Bearing**

Turn front bearing by hand and check for looseness and abnormal noise. Replace if necessary.

**Rear Bearing**

Turn rear bearing by hand and check for looseness and abnormal noise. Replace if necessary.

## SPECIFICATIONS

### BATTERY

Battery type	115D31L
Rated capacity AH/5HR, 12 Volts	72
Electrolyte ℓ (US/Imp. pt)	4.5 (9.51/7.92)
Electrolyte S.G.	1.28 when fully charged at 20°C (68°F)

### GENERATOR

Type	70 A type
Rated voltage	12 V
Nominal output	70 A
Permissible max. speed	11000 r/min.
No-load speed	1100 r/min (rpm)
Setting voltage (at 20°C, 68°F)	14.1 to 14.7 V
Permissible ambient temperature	-30 to 80°C (-22 to 176°F)
Polarity	Negative ground
Rotation	Clockwise viewed from pulley side

## TIGHTENING TORQUE SPECIFICATIONS

Fastening		Tightening torque		
		N-m	kg-m	lb-ft
● Generator mounting bolt	Lower side	23	2.3	16.5
	Upper side	53	5.3	38.5
● "B" terminal nut		8	0.8	6.0
● Pulley nut		110	11.0	79.5
● Generator case bolt		5	0.5	4.0
● Vacuum pump mounting bolt		8	0.8	6.0
● Vacuum hose bolt		33	3.3	24.0
● Oil hose bolt	M18	33	3.3	24.0
	M8	10	1.0	7.5

## SPECIAL TOOLS

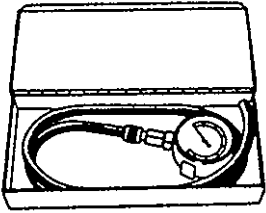

09915-67310  
Vacuum gauge

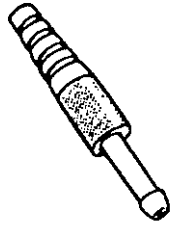

09918-08210  
Vacuum hose joint

## SECTION 6K

# EXHAUST SYSTEM

**NOTE:**

For the descriptions (items) not found in this section, refer to the same section of the Service Manual mentioned in FOREWORD of this manual.

**CONTENTS**

GENERAL DESCRIPTION .....	6K-1
ON-VEHICLE SERVICE .....	6K-2

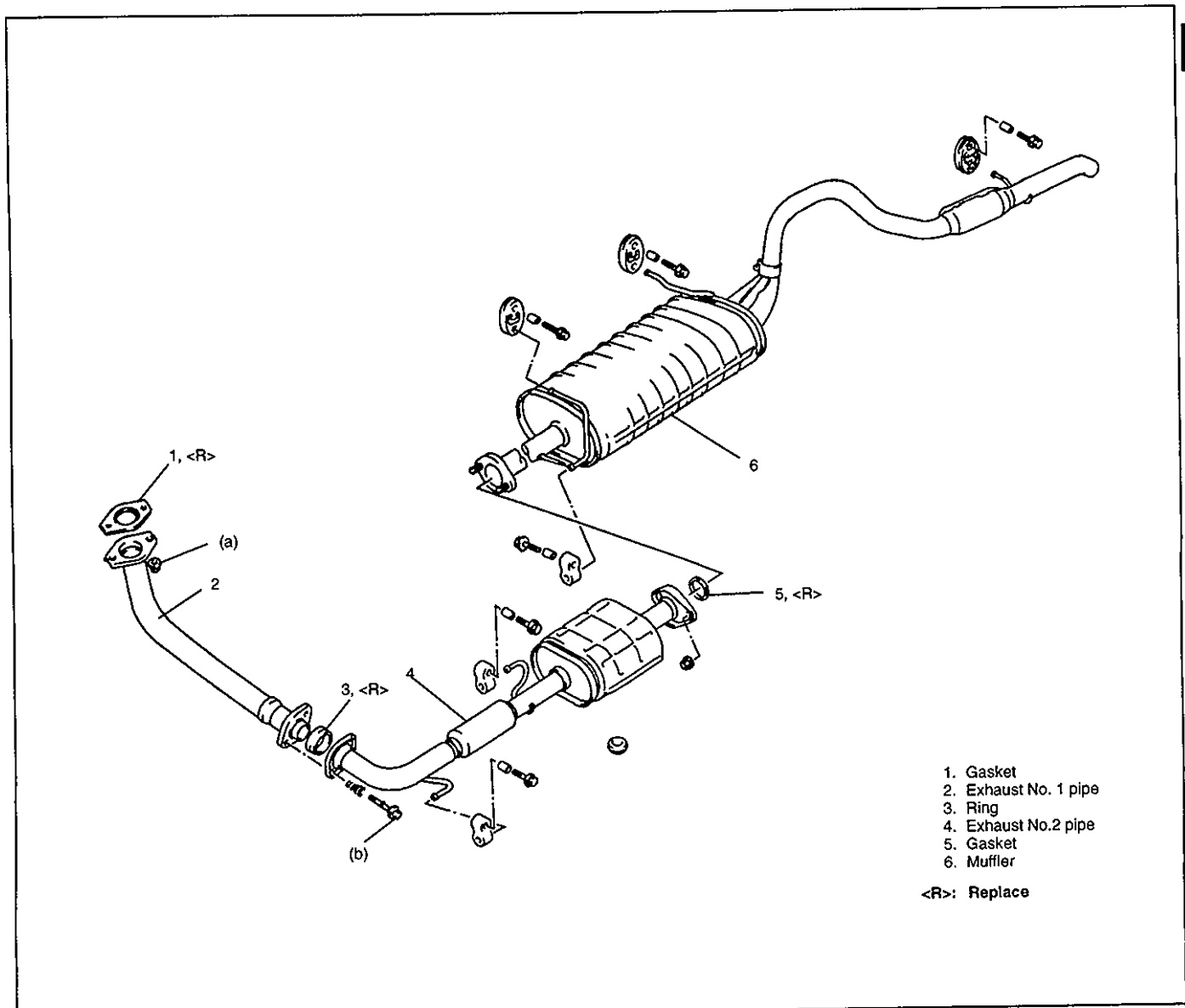
**GENERAL DESCRIPTION**

## ON-VEHICLE SERVICE

**WARNING:**

To avoid the danger of being burned, do not touch the exhaust system when the system is hot. Any service on the exhaust system should be performed when the system is cool.

**Tightening Torque**

(a): 60 N·m (6.0 kg-m, 43.5 lb-ft)

(b): 50 N·m (5.0 kg-m, 36.5 lb-ft)

**EXHAUST MANIFOLD**

Refer to Section 6A3 for removal and installation procedures. Before installation, check gasket and seal for deterioration or damage. Replace them as necessary.

**MUFFLER**

**CAUTION:**

As muffler center pipe has three way catalytic converter in it, it should not be exposed to any impulse. Be careful not to drop it or hit it against something.

Refer to figure of previous page for removal and installation.

## SECTION 7B1

# AUTOMATIC TRANSMISSION

## (4 A/T)

**WARNING:**

For vehicles equipped with Supplemental Restraint (Air Bag) System

- Service on and around the air bag system components or wiring must be performed only by an authorized SUZUKI dealer. Refer to “Air Bag System Components and Wiring Location View” under “General Description” in air bag system section in order to confirm whether you are performing service on or near the air bag system components or wiring. Please observe all WARNINGS and “Service Precautions” under “On-Vehicle Service” in air bag system section before performing service on or around the air bag system components or wiring. Failure to follow WARNINGS could result in unintentional activation of the system or could render the system inoperative. Either of these two conditions may result in severe injury.
- Technical service work must be started at least 90 seconds after the ignition switch is turned to the “LOCK” position and the negative cable is disconnected from the battery. Otherwise, the system may be activated by reserve energy in the Sensing and Diagnostic Module (SDM).

### CONTENTS

<b>GENERAL DESCRIPTION</b> .....	7B1- 2	Diagnostic Flow Chart C .....	7B1-12
<b>AUTOMATIC GEAR SHIFT DIAGRAM</b> ....	7B1- 4	Diagnostic Flow Chart D .....	7B1-14
<b>DIAGNOSIS</b> .....	7B1- 5	DTC 21, 23 or 25 – Solenoid Circuit .....	7B1-15
<b>TRANSMISSION UNIT</b> .....	7B1- 5	DTC 22, 24 or 26 – Solenoid Circuit .....	7B1-16
Trouble Diagnosis Table .....	7B1- 5	DTC 31 Vehicle Speed Sensor (A/T) ....	7B1-17
Line Pressure Test .....	7B1- 5	DTC 32 – Throttle Opening Signal .....	7B1-18
Stall Test .....	7B1- 6	DTC 33 – Throttle Opening Signal .....	7B1-19
<b>ELECTRONIC SHIFT CONTROL</b>		DTC 34 – Transmission Range	
<b>SYSTEM</b> .....	7B1- 8	Switch Circuit .....	7B1-20
On-board Diagnostic System		DTC 36 – Vehicle Speed Sensor	
(Self-Diagnosis Function) .....	7B1- 8	(A/T and Meter) .....	7B1-21
Precautions In Diagnosing Troubles .....	7B1- 8	DTC 51 – Engine Coolant Temp. Signal .	7B1-22
System Circuit Diagram .....	7B1- 9	<b>ON-VEHICLE SERVICE</b> .....	7B1-23
Diagnostic Trouble Code(s)		Fluid Change .....	7B1-23
Clearance .....	7B1-10	Throttle Position (TP) Sensor .....	7B1-23
Diagnostic Trouble Code Table		<b>UNIT REPAIR</b> .....	7B1-25
(A/T Related Code) .....	7B1-10	<b>TIGHTENING TORQUE</b>	
Fail-Safe Table .....	7B1-10	<b>SPECIFICATIONS</b> .....	7B1-25
Diagnostic Flow Chart A .....	7B1-11	<b>REQUIRED SERVICE MATERIALS</b> .....	7B1-25
Diagnostic Flow Chart B .....	7B1-11	<b>SPECIAL TOOL</b> .....	7B1-25

## GENERAL DESCRIPTION

This automatic transmission is a full automatic type with 3-speed plus overdrive (O/D).

The torque converter is a 3-element, 1-step and 2-phase type and is equipped with an electronically controlled lock-up mechanism. The gear shift device consists of 3 sets of planetary gear units, 3 disc type clutches, 4 disc type brakes and 3 one-way clutches. The gear shift is done by selecting one of 6 positions ("P", "R", "N", "D", "2" and "L") by means of the select lever installed on the floor. On the shift knob, there is an overdrive (O/D) cut switch which allows shift-up to the overdrive mode (except at 4L) and shift-down from the overdrive mode. Also, by using the P/N change switch located on the console box, it is possible to select the gear change timing of 2 modes, normal and power.

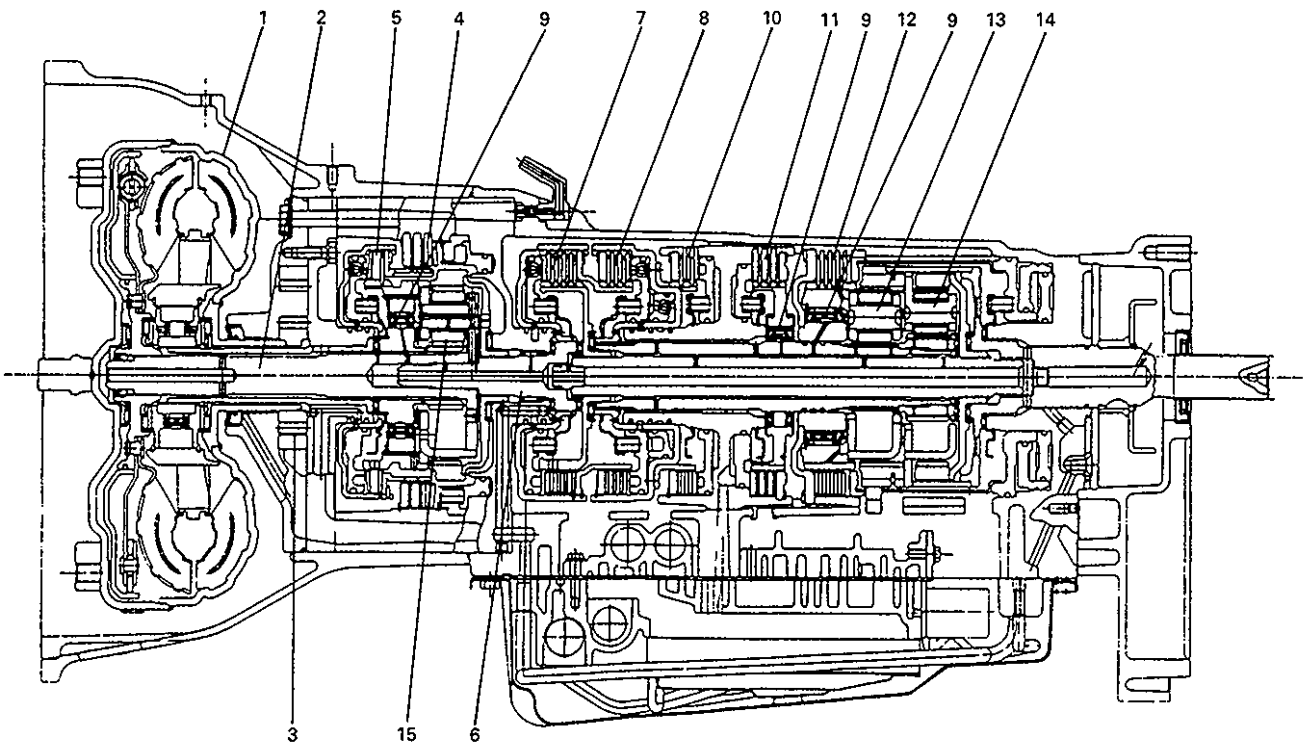

1. Torque converter
2. Overdrive input shaft
3. Oil pump
4. Overdrive brake
5. Overdrive clutch
6. Forward clutch input shaft
7. Forward clutch
8. Direct clutch
9. One-way clutch
10. Second coast brake
11. Second brake
12. Reverse brake
13. Front planetary gear
14. Rear planetary gear
15. Overdrive planetary gear

Item		Specifications	
Torque converter	Type Stall torque ratio	3-element, 1-step, 2-phase type (with TCC (lock-up) mechanism) 1.9 (RF)	
Oil pump	Type Drive system	Trochoid type oil pump Engine driven	
Gear change device	Type	Forward 4-step, reverse 1-step planetary gear type	
	Shift position	"P" range	Gear in neutral, output shaft fixed, engine start
		"R" range	Reverse
		"N" range	Gear in neutral, engine start
		"D" range (O/D ON)	Forward 1st ↔ 2nd ↔ 3rd ↔ 4th (O/D) automatic gear change
		"D" range (O/D OFF)	Forward 1st ↔ 2nd ↔ 3rd ↔ 4th automatic gear change
		"2" range	(Normal mode) Forward 1st ↔ 2nd ↔ 3rd automatic gear change (Power mode) Forward 2nd ← 3rd automatic gear change and fixed at 2nd gear
	"L" range	Forward 1st ← 2nd reduction, and fixed at 1st gear	
	Engine type	RF	
	Gear ratio	1st (low gear)	2.826
2nd (second gear)		1.493	
3rd (top gear)		1.000	
4th (overdrive gear)		0.730	
Reverse (reverse gear)		2.703	
Control elements	Wet type multi-disc clutch . . . . . 3 sets Wet type multi-disc brake . . . . . 4 sets One-way clutch . . . . . 3 sets		
Transfer	Hi: 1.000      Lo: 1.816 (4WD model only)		
Final gear reduction ratio (Differential)	4.300 (RF engines)		
Lubrication	Lubrication system	Force feed system by oil pump	
Cooling	Cooling system	Radiator assisted cooling (water-cooled)	
Fluid used		An equivalent of DEXRON®II, DEXRON®IIE or DEXRON®III	

# AUTOMATIC GEAR SHIFT DIAGRAM

Automatic shift schedule as a result of shift control is shown below.

## Power Mode

Gear Shift Diagram

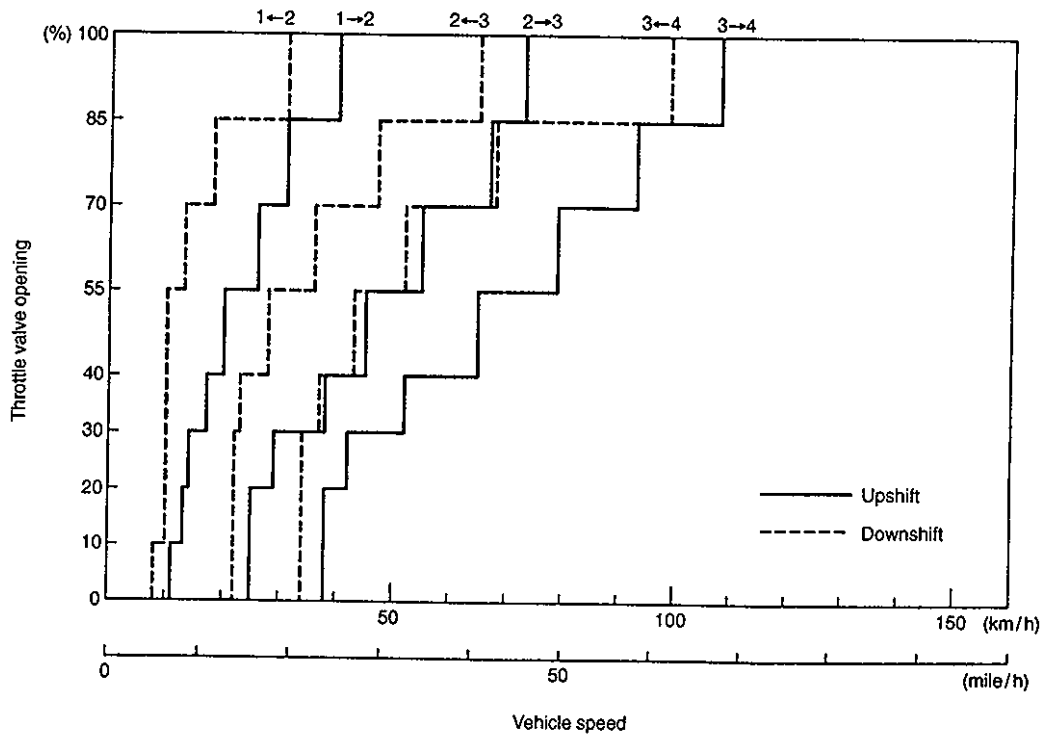

TCC Lock-up Diagram

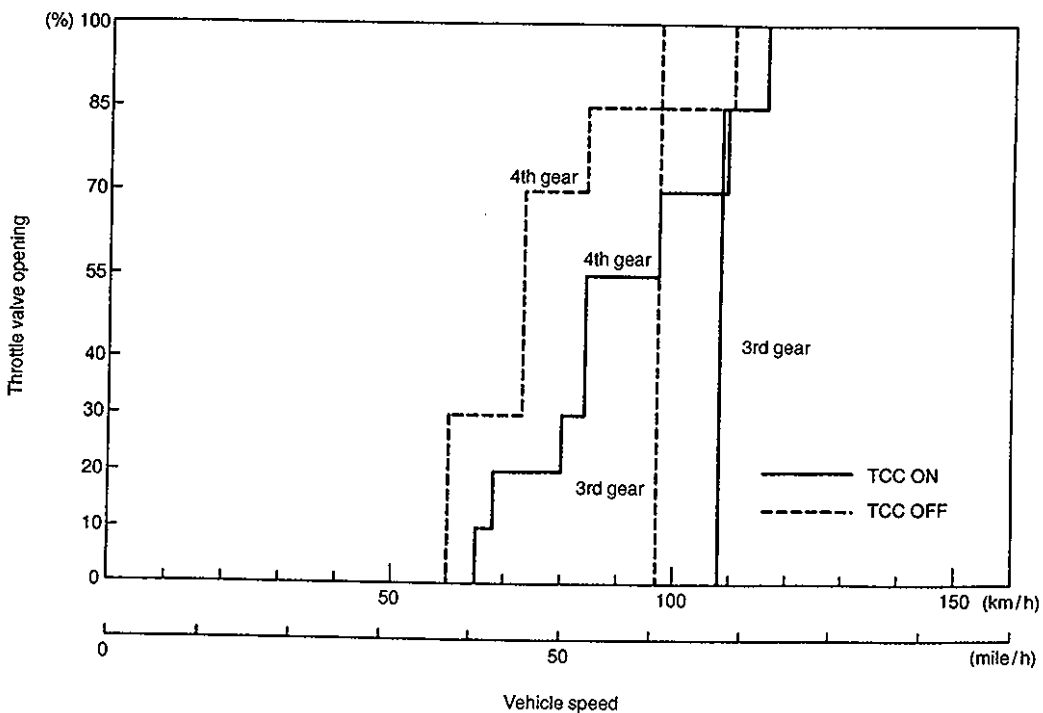

# DIAGNOSIS

## TRANSMISSION UNIT

### Trouble Diagnosis Table

Refer to the same section of Service Manual mentioned in FOREWORD of this manual except for the input sensor.

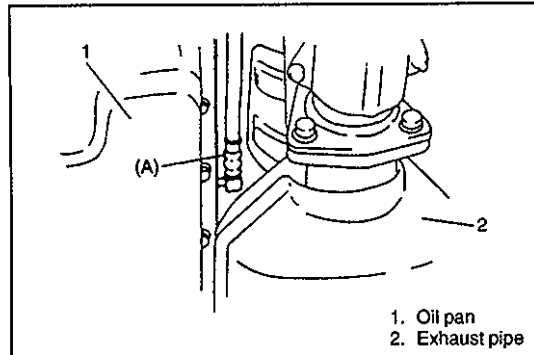
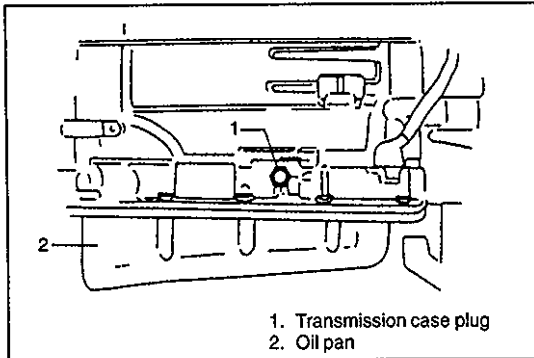

### LINE PRESSURE TEST

Purpose of this test is to check operating conditions of each part by measuring fluid pressure in fluid pressure line.

Line pressure test requires following conditions.

- Automatic fluid is at normal operating temperature (70 to 80°C/158 – 176°F).
- Fluid is filled to proper level (between FULL HOT and LOW HOT on dipstick).

- 1) Apply parking brake securely and place checks against wheels.
- 2) Remove transmission case plug and attach special tool.

#### Special Tool

(A): 09925-37810

#### CAUTION:

After attaching oil pressure gauge, check that no fluid leakage exists.

- 3) Depress foot brake fully, run engine at idle and stall and then check fluid pressure in “D” or “R” range.

#### CAUTION:

Do not continue running engine at stall speed longer than 5 seconds.

[RF engine]

Engine running mode	Line pressure	
	“D” range	“R” range
At idle speed	3.7 – 4.1 kg/cm <sup>2</sup> 53 – 58 psi	5.1 – 5.7 kg/cm <sup>2</sup> 73 – 81 psi
At stall speed	10.7 – 12.2 kg/cm <sup>2</sup> 152 – 173 psi	13.8 – 16.3 kg/cm <sup>2</sup> 196 – 232 psi

Check result	Possible cause
Line pressure higher than standard level in each range	<ul style="list-style-type: none"> <li>● Malfunctioning regulator valve</li> <li>● Malfunctioning throttle valve</li> <li>● Maladjusted A/T throttle cable</li> </ul>
Line pressure lower than standard level in each range	<ul style="list-style-type: none"> <li>● Defective O/D clutch</li> <li>● Defective oil pump</li> <li>● Malfunctioning throttle valve</li> <li>● Malfunctioning regulator valve</li> <li>● Maladjusted A/T throttle cable</li> </ul>
Line pressure lower than standard level only in "D" range	<ul style="list-style-type: none"> <li>● Fluid leakage from forward clutch</li> <li>● Defective O/D clutch</li> <li>● Leakage from "D" range fluid pressure circuit</li> </ul>
Line pressure lower than standard level only in "R" range	<ul style="list-style-type: none"> <li>● Fluid leakage from direct clutch</li> <li>● Fluid leakage from reverse brake</li> <li>● Fluid leakage from "R" range fluid circuit</li> </ul>

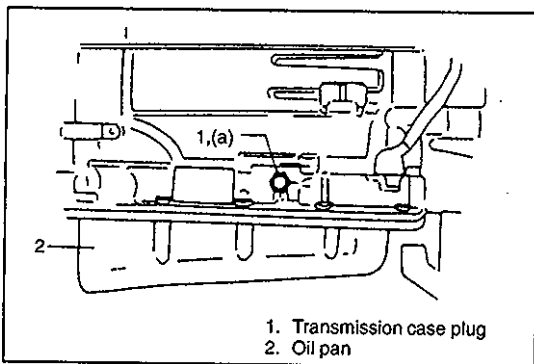

4) Remove special tool and attach transmission case plug.

#### Tightening Torque

(a): 17 N·m (1.7 kgm, 12.0 lb-ft)

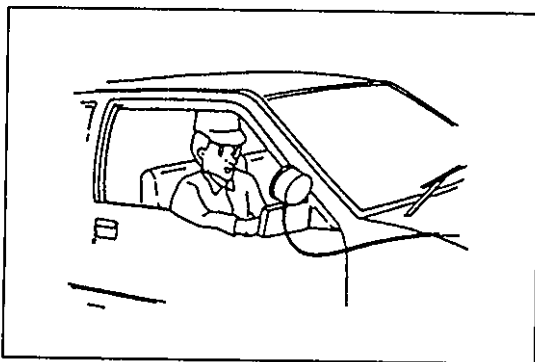

#### STALL TEST

This test is to check overall performance of automatic transmission and engine by measuring stall speed at "D" and "R" ranges. Be sure to perform this test only when transmission fluid is at normal operating temperature and its level is between FULL and LOW marks.

#### CAUTION:

- Do not run engine at stall more than 5 seconds continuously, for fluid temperature may rise excessively high.
- After performing stall test, be sure to leave engine running at idle for longer than 30 seconds before another stall test.

- 1) Apply parking brake and block wheels.
- 2) Install tachometer.
- 3) Start engine with select lever shifted to "P".
- 4) Depress brake pedal fully.
- 5) Shift select lever to "D" and depress accelerator pedal fully while watching tachometer. Read engine rpm quickly when it has become constant (stall speed).
- 6) Release accelerator pedal immediately after stall speed is checked.
- 7) In the same way, check stall speed in "R" range.

8) Stall speed should be within following specification.

**Stall speed: 2,050 – 2,350 r/min .... RF engine**

Check result	Possible cause
Lower than standard level	<ul style="list-style-type: none"> <li>● Faulty engine output</li> <li>● Defective torque converter</li> </ul>
Higher than standard level in "D" range	<ul style="list-style-type: none"> <li>● Slippery O/D clutch</li> <li>● Slippery forward clutch</li> <li>● Malfunctioning O/D one-way clutch</li> <li>● Malfunctioning one-way clutch No.2</li> <li>● Low line pressure</li> </ul>
Higher than standard level in "R" range	<ul style="list-style-type: none"> <li>● Slippery direct clutch</li> <li>● Slippery reverse brake</li> <li>● Low fluid pressure</li> <li>● Slippery O/D clutch</li> <li>● Defective O/D one-way clutch</li> </ul>

## ELECTRONIC SHIFT CONTROL SYSTEM

The transmission control module (TCM) with on-board diagnostic system (self-diagnosis function) operates as described below. When diagnosing a trouble in the electronic shift control system, use "DIAGNOSTIC FLOW CHART" and "DIAGNOSTIC TROUBLE CODE TABLE" on the following page.

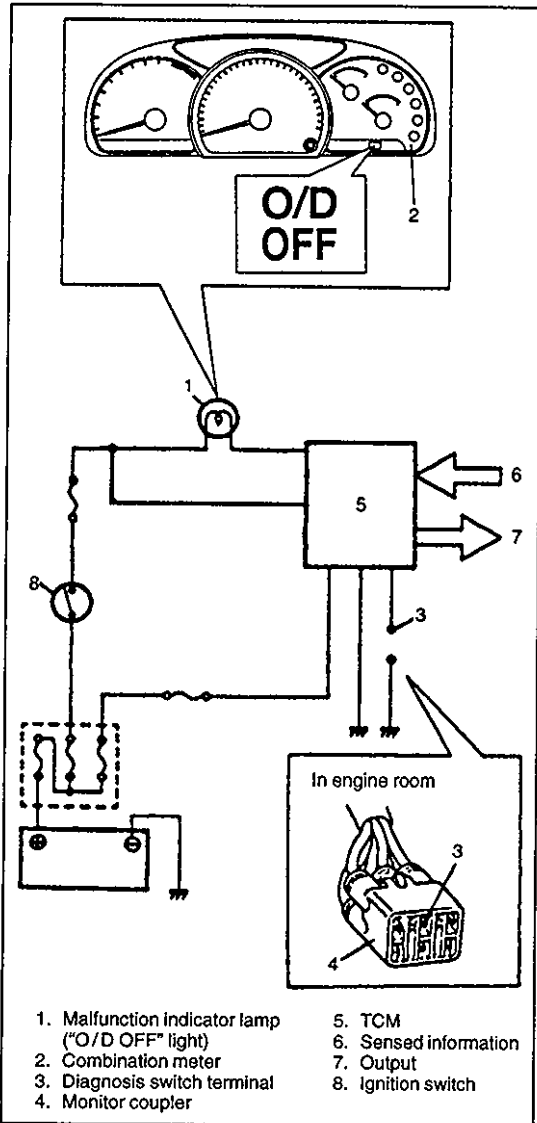

### ON-BOARD DIAGNOSTIC SYSTEM (SELF-DIAGNOSIS FUNCTION)

The system has three major functions as explained below.

- TESTING DIAGNOSTIC CIRCUIT AND BULB

The "O/D OFF" light functions as a malfunction indicator lamp when diagnosing the transmission control system. The lamp turns on for approximately 2 seconds when the ignition switch is turned to ON position with the O/D cut switch off. It can be determined that the system functions normal if the lamp turns on.

- INDICATING OCCURRENCE OF TROUBLE

The malfunction indicator lamp turns on and off alternately with the ignition switch at ON position should malfunction occur in the electronic control system.

- INDICATING DIAGNOSTIC TROUBLE CODE

The malfunction indicator lamp indicates diagnostic trouble code(s) by a blinking signal when the ignition switch is turned to ON position while grounding diagnostic switch terminal of monitor coupler.

### PRECAUTIONS IN DIAGNOSING TROUBLES

- Refer to the same section of the Service Manual mentioned in FOREWORD of this manual.
- This system use "O/D OFF" light as malfunction indicator light.
- This system can not use Suzuki scan tool.

**SYSTEM CIRCUIT DIAGRAM**

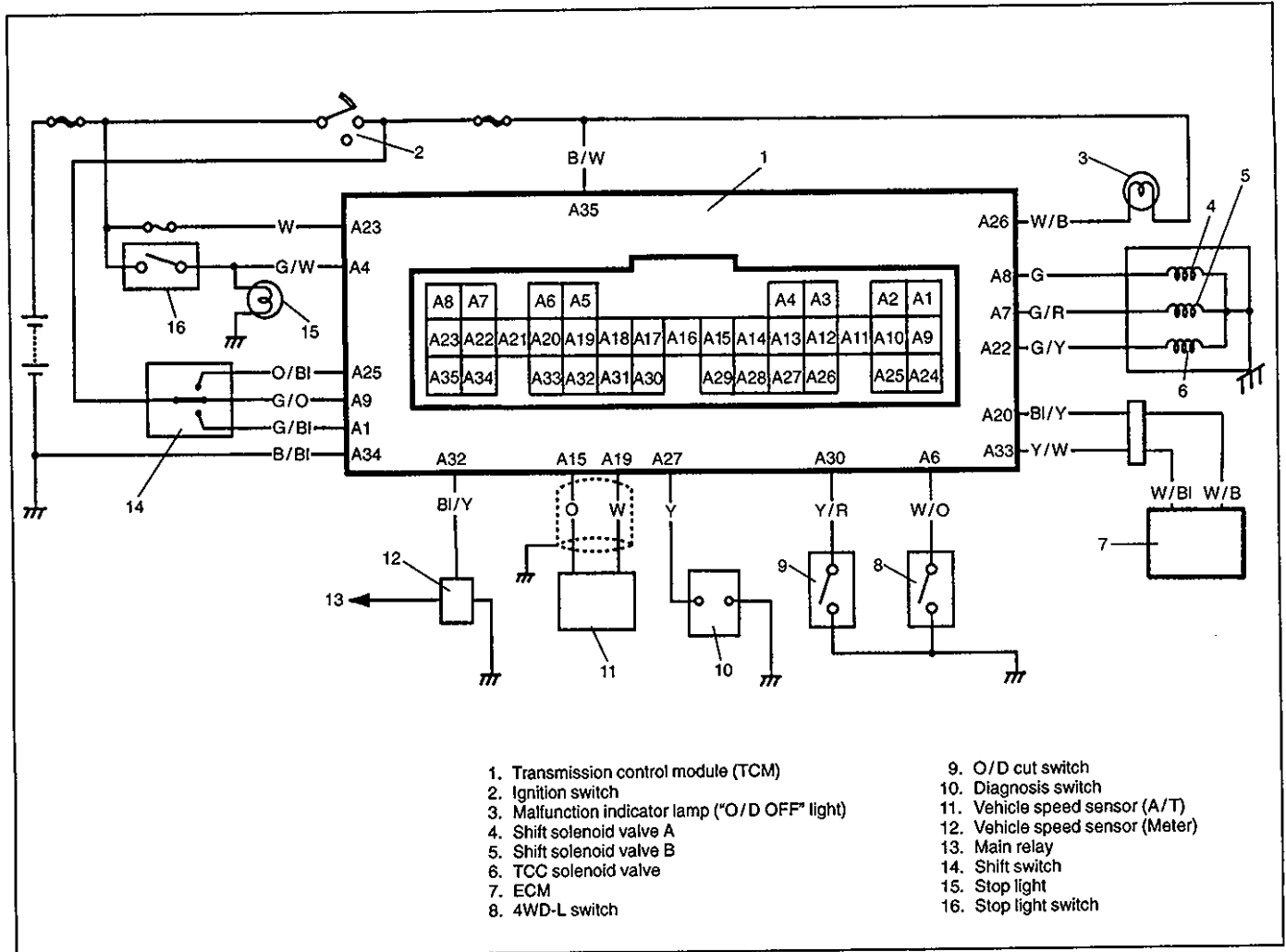

TERMINAL	CIRCUIT	TERMINAL	CIRCUIT
A1	Shift switch L	A19	Vehicle speed sensor (T/M)
A2	---	A20	TP sensor signal (From ECM)
A3	---	A21	---
A4	Stop light switch	A22	TCC solenoid valve
A5	Vehicle speed sensor (A/T) (-)	A23	Backup power supply
A6	4WD-L switch	A24	---
A7	Shift solenoid valve B	A25	Shift switch N
A8	Shift solenoid valve A	A26	Malfunction indicator lamp ("O/D OFF" light)
A9	Shift switch 2	A27	Diagnosis switch
A10	---	A28	---
A11	---	A29	---
A12	---	A30	O/D cut switch
A13	---	A31	---
A14	---	A32	Vehicle speed sensor (A/T and Meter)
A15	---	A33	ECT sensor signal (From ECM)
A16	---	A34	Ground
A17	---	A35	Ignition switch
A18	---		

**DIAGNOSTIC TROUBLE CODE(S) CLEARANCE**

- 1) Turn ignition switch ON
- 2) Ground diagnosis switch terminal 5 times or more within 10 minutes.

**DIAGNOSTIC TROUBLE CODE TABLE (A/T RELATED CODE)**

Code No.	Diagnostic Area	Diagnosis
12	-	Normal
21	Shift solenoid valve A	Shift solenoid valve A or its circuit open or shorted to power circuit.
22		Shift solenoid valve A or its circuit shorted to ground.
23	Shift solenoid valve B	Shift solenoid valve B or its circuit open or shorted to power circuit.
24		Shift solenoid valve B or its circuit shorted to ground.
25	TCC solenoid valve	TCC solenoid valve or its circuit open or shorted to power circuit.
26		TCC solenoid valve or its circuit shorted to ground.
31	Vehicle speed sensor (A/T)	Defective sensor or its circuit (open or short)
32	TP sensor	Defective sensor or its circuit (open)
33	TP sensor	Defective sensor or its circuit (short)
34	Transmission range switch	Defective switch or its circuit (more than two shift switches of "R", "N", "D", "2" and "L" turned ON simultaneously or no shift switch turned ON while vehicle running).
36	Vehicle speed sensor (A/T and Meter)	Defective sensor or its circuit. (open or short)
51	ECT sensor	Defective sensor or its circuit (open)

**FAIL-SAFE TABLE**

Code No.	Diagnostic Area	Fail-Safe Function
21	Shift solenoid valve A	Shift solenoid valve B. 1st, 2nd and 3rd gears ON, 4th (O/D) gear OFF. For shift position, refer to FAIL-SAFE FUNCTION in ELECTRONIC SHIFT CONTROL SYSTEM.
22		
23	Shift solenoid valve B	Shift solenoid valve A. 1st gear ON, 2nd 3rd and 4th (O/D) gears OFF. For shift position, refer to FAIL-SAFE FUNCTION in ELECTRONIC SHIFT CONTROL SYSTEM.
24		
25	TCC solenoid valve	TCC solenoid valve OFF.
26		
31	Vehicle speed sensor (A/T)	Signal from vehicle speed sensor (Meter) is used.
32	TP sensor	Throttle opening is controlled as closed.
33		
34	Transmission range switch	Priority order is "L" → "2" → "N". (When two or more signals inputted same time) Transmission range switch is controlled as "D" range. (When no signal inputted)
36	Vehicle speed sensor (A/T and Meter)	Shift solenoid valve A and B is controlled as OFF.
51	ECT sensor	After 15 min. from engine start, PCM release inhibitions of shift to O/D gear and TCC lock-up.

### DIAGNOSTIC FLOW CHART A

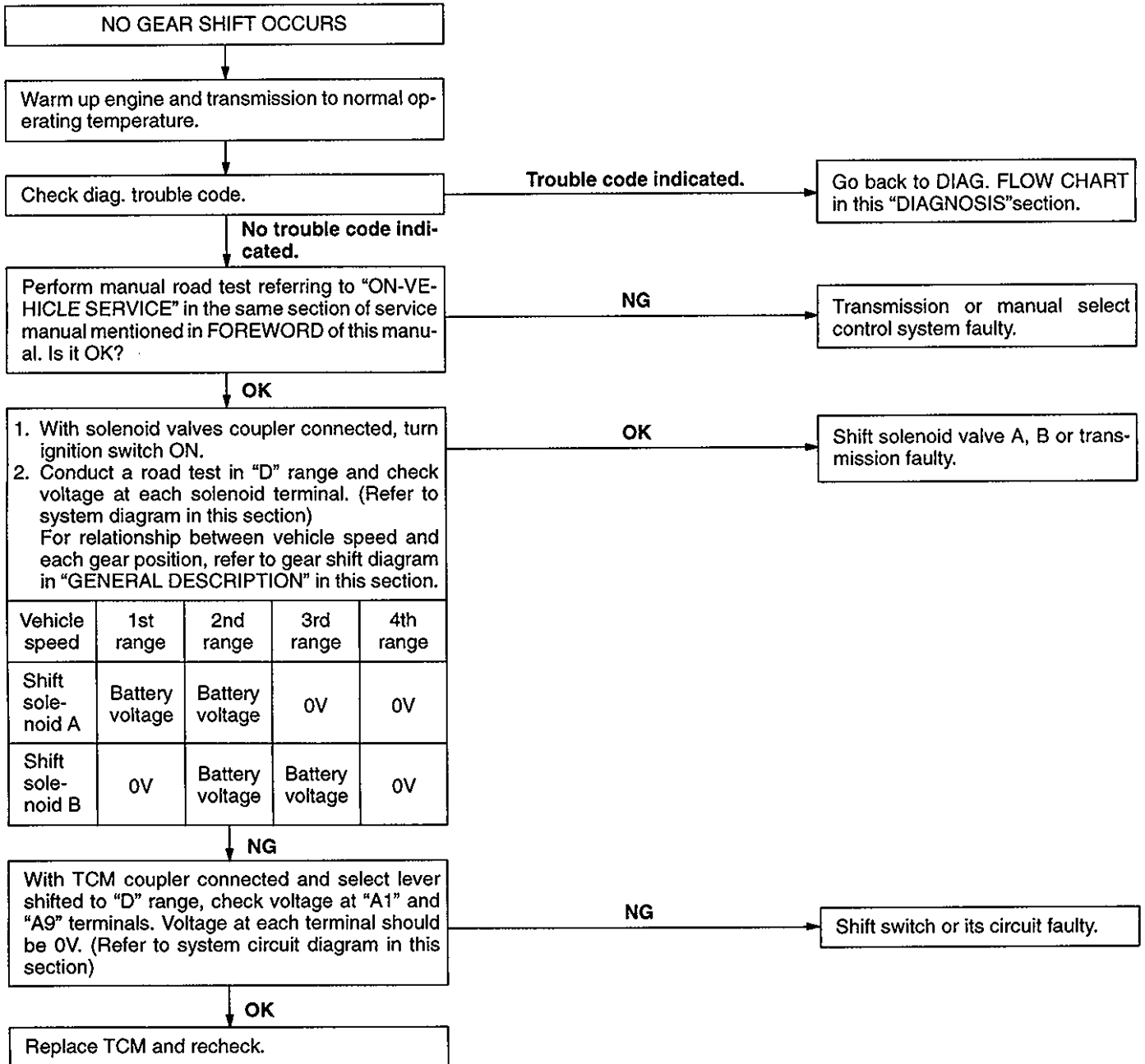

### DIAGNOSTIC FLOW CHART B

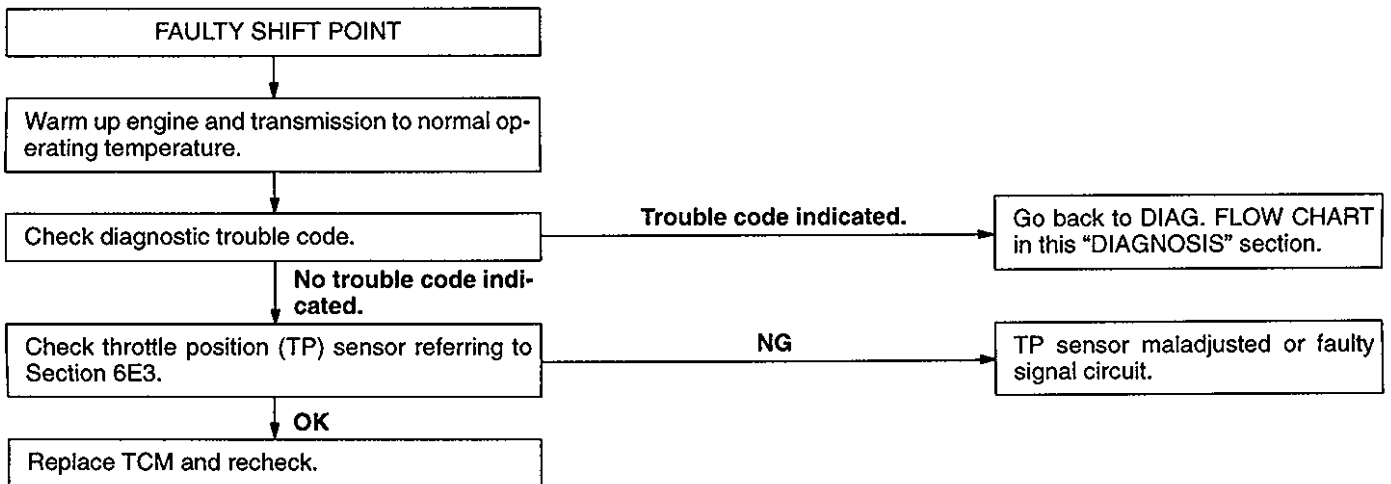

### DIAGNOSTIC CHART C

NO GEAR SHIFT TO O/D

Warm up engine and transmission to normal operating temperature.

Check diag. trouble code.

Trouble code indicated.

Go back to DIAG. FLOW CHART in this "DIAGNOSIS" section.

No trouble code indicated

Perform manual road test referring to "ON-VEHICLE SERVICE" in the same section of service manual mentioned in FOREWORD of this manual.  
Does gear shift to O/D (4th gear) occur in manual road test?

NG

Manual select control system or transmission faulty.

OK

1. With ignition switch OFF, connect solenoid valves coupler.  
2. Conduct road test in "D" range and check voltage at each solenoid terminal. (Refer to system circuit diagram in this section)

Vehicle speed	1st range	2nd range	3rd range	4th range
Shift solenoid A	Battery voltage	Battery voltage	0V	0V
Shift solenoid B	0V	Battery voltage	Battery voltage	0V

OK

Shift solenoid valve A, B or transmission faulty.

NG

1. With TCM coupler connected, turn ignition switch ON.  
2. With select lever shifted to "D" range, check voltage at "A1" and "A9" terminals. It should be 0V. (Refer to system circuit diagram in this section)

NG

Shift switch or its circuit faulty.

OK

With coupler connected, check voltage at "A30" terminal. (Refer to system circuit diagram in this section.)

O/D cut switch position	OFF	ON
Voltage	Battery voltage	0V

NG

Faulty O/D cut switch or its circuit shorted.

OK

To be continued

Continued

Check ECT sensor referring to Section 6E3. Is it in good condition?

NG

ECT sensor faulty.

OK

With coupler connected, check voltage at "A6" terminal. (Refer to system circuit diagram in this section)

NG

Faulty 4WD-Low switch or its circuit shorted.

Transfer gear position	"4L" or "N" position	"4H" or "2H" position
Voltage	0V	Battery voltage

OK

Replace TCM and recheck.

### DIAGNOSTIC FLOW CHART D

NO TCC LOCK-UP OCCURS

Warm up engine and transmission to normal operating temperature.

Check diag. trouble code.

Trouble code indicated.

Go back to DIAG. FLOW CHART in this "DIAGNOSIS" section.

No trouble code indicated.

Conduct road test under following conditions and check if battery voltage is obtained at "A22" terminal. (Refer to system circuit diagram in this section.)

- O/D cut switch OFF. (O/D OFF light turn ON)
- Normal mode in "D" range.
- Transfer "2H" gear position.
- Accelerate till vehicle speed reaches about 80 km/h and reduce throttle valve opening so that it is open less than 20%.

OK

TCC solenoid valve or transmission faulty.

NG

Check voltage at "A4" terminal. (Refer to system circuit diagram in this section)		
Brake pedal	When released	When depressed
Voltage	0V	Battery voltage

NG

Faulty brake pedal switch or its circuit shorted.

OK

Check ECT sensor referring to Section 6E3. Is it in good condition?

NG

ECT sensor faulty.

OK

Check voltage at "A6" terminal. (Refer to system circuit diagram in this section)		
Transfer gear position	"4L" or "N" position	"4H" or "2H" position
Voltage	0V	Battery voltage

NG

Faulty 4WD-Low switch or its circuit shorted.

OK

Replace TCM and recheck.

**DTC 21 – SHIFT SOLENOID A CIRCUIT**  
**DTC 23 – SHIFT SOLENOID B CIRCUIT**  
**DTC 25 – TCC SOLENOID CIRCUIT**

(OPEN OR SHORT TO POWER CIRCUIT)

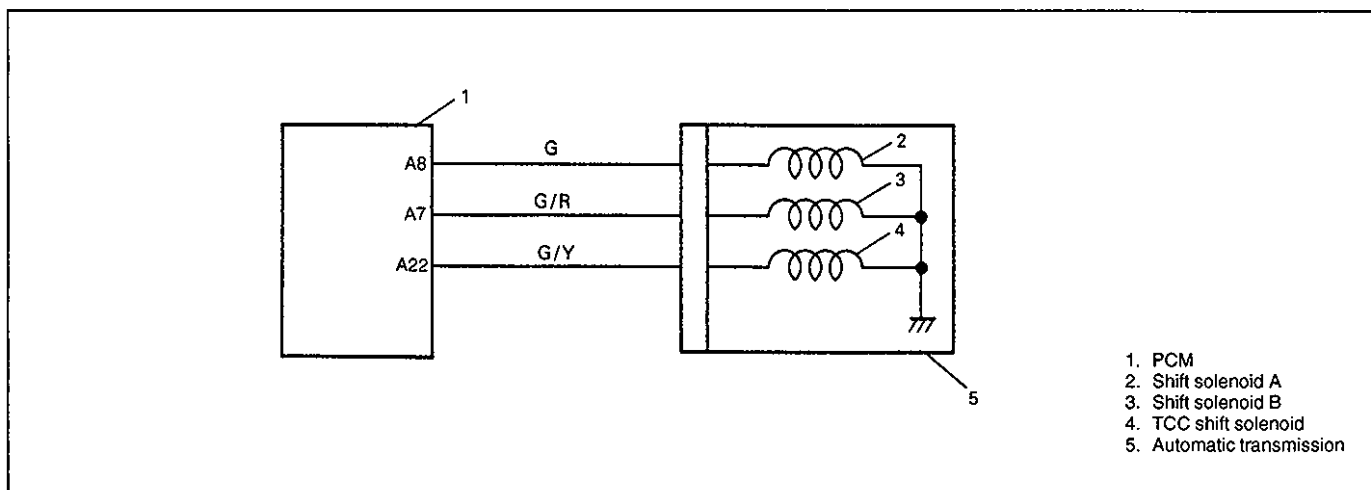

1. Disconnect TCM coupler with ignition switch OFF.  
 2. Check resistance between "A7", "A8" or "A22" terminal of disconnected TCM coupler and body ground.  
 3. Is it 11 – 15 Ω?

YES

NO

1. Turn ON ignition switch with TCM coupler disconnected.  
 2. Check voltage between "A7", "A8" or "A22" terminal of disconnected TCM coupler and body ground.  
 3. Is it about 0 V?

Check shift solenoid valve A, shift solenoid valve B or TCC solenoid valve, referring to SOLENOID VALVES in "ON-VEHICLE SERVICE" in this section.  
 Is it OK?

YES

NO

YES

NO

Shift solenoid valve A, shift solenoid valve B or TCC solenoid valve faulty.

Poor "A7", "A8" or "A22" terminal connection of TCM coupler.  
 If connection is OK, substitute a known-good TCM and re-check.

"G", "G/R" or "G/Y" wire open or shorted to power circuit.

**DTC 22 – SHIFT SOLENOID A CIRCUIT**  
**DTC 24 – SHIFT SOLENOID B CIRCUIT**  
**DTC 26 – TCC SOLENOID CIRCUIT**

(SHORT TO GROUND)

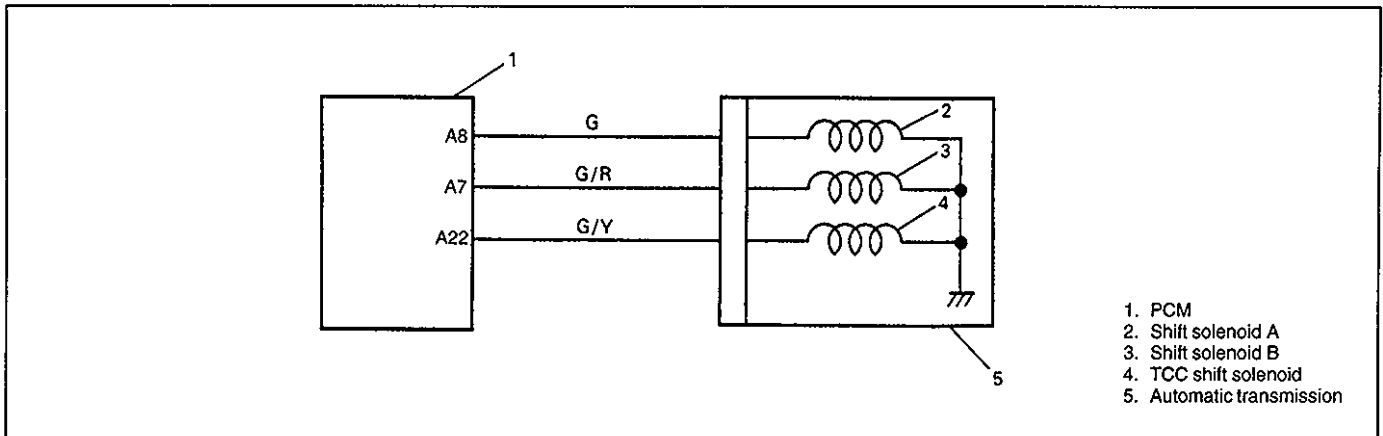

- 1. PCM
- 2. Shift solenoid A
- 3. Shift solenoid B
- 4. TCC shift solenoid
- 5. Automatic transmission

1. Disconnect TCM couplers with ignition switch OFF.  
 2. Check resistance between "A7", "A8" or "A22" terminal of disconnected TCM coupler and body ground.  
 3. Is it 11 – 15 Ω ?

**YES**

Poor "A7", "A8" or "A22" terminal connection of TCM coupler.  
 If connection is OK, substitute a known-good TCM and recheck.

**NO**

Check shift solenoid valve A, shift solenoid valve B or TCC solenoid valve, referring to SOLENOID VALVES in "ON-VEHICLE SERVICE" in the same section of service manual mentioned in FOREWORD of this manual.  
 Is it OK?

**YES**

"G", "G/R" or "G/Y" wire shorted to ground.

**NO**

Shift solenoid valve A, shift solenoid valve B or TCC solenoid valve faulty.

## DTC 31 – VEHICLE SPEED SENSOR (A/T) (VEHICLE SPEED SIGNAL NOT INPUTTED)

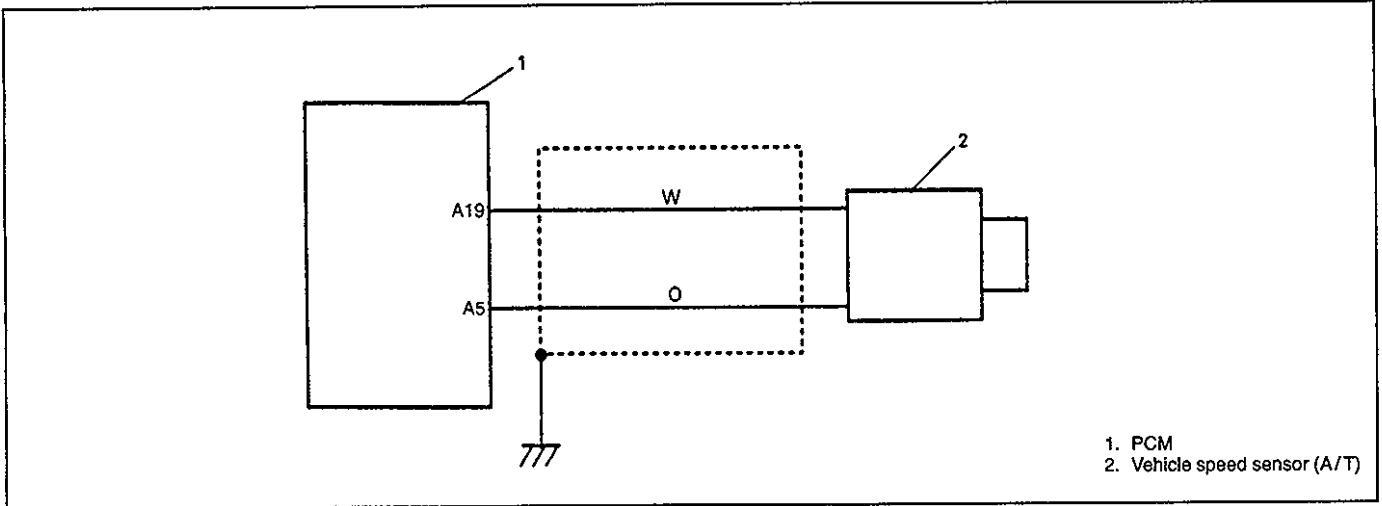

1. Disconnect TCM coupler with ignition switch OFF.
2. Check resistance between "A5" and "A19" terminal of disconnected TCM coupler.  
Is it 369 – 451  $\Omega$ ?

YES

NO

1. Connect TCM coupler with ignition switch OFF.
  2. Hoist vehicle to rotate all wheels freely.
- WARNING:**  
Before this test, check to make sure that no one or nothing is near wheels as they rotate at high speed during testing.
3. Check voltage between "A5" and "A19" terminal of TCM coupler when vehicle running at 40 km/h on lift.  
Is it 0.5 – 1.0 V by using AC voltmeter?

"W" or "O" wire open or poor coupler connection.  
If wire and connection are OK, replace A/T vehicle speed sensor.

YES

NO

Poor "A5" or "A19" terminal connection.  
If connections are OK, substitute a known-good TCM and recheck.

Improper installation or faulty A/T vehicle speed sensor.

### DTC 32 – THROTTLE OPENING SIGNAL (SIGNAL VOLTAGE LOW: OPENING HIGH)

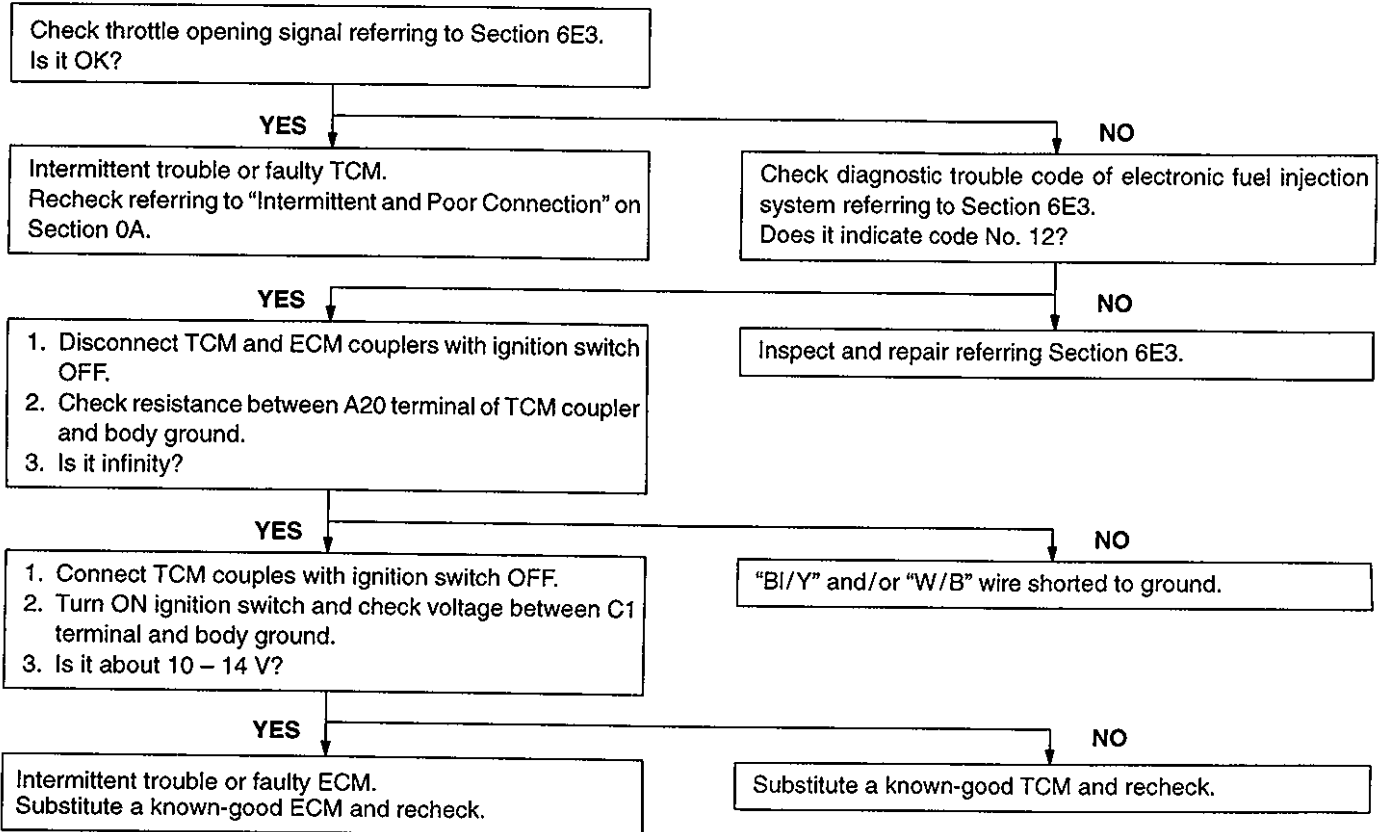
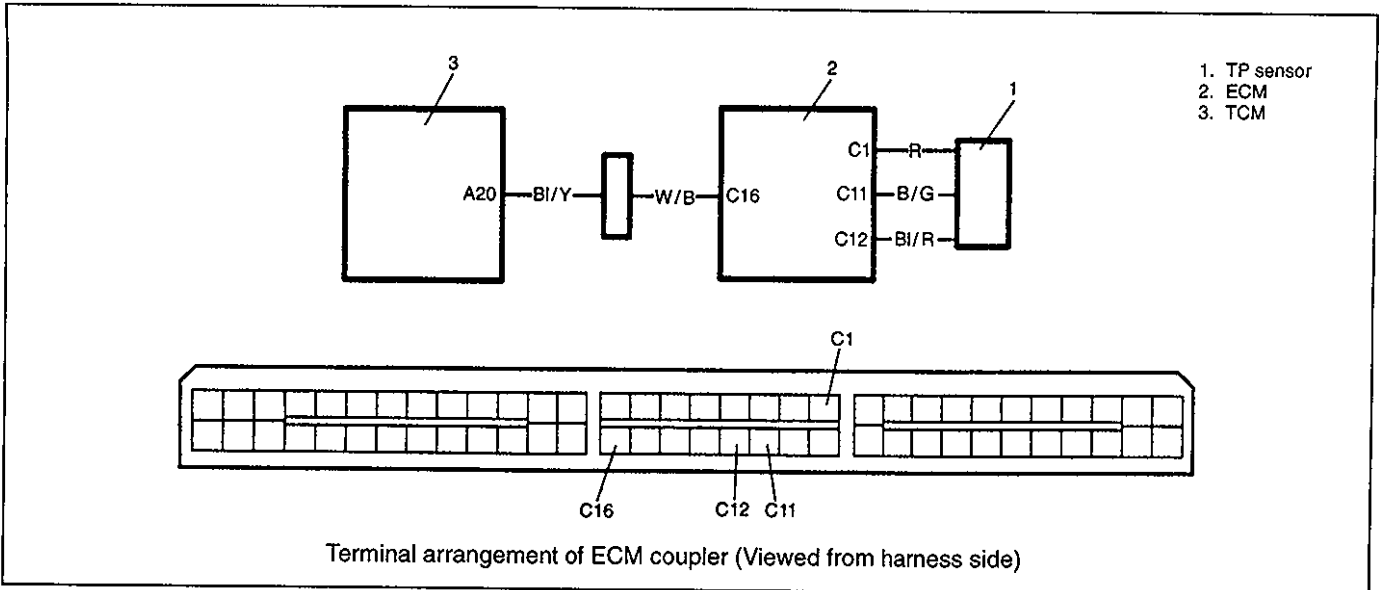

**DTC 33 – THROTTLE OPENING SIGNAL (SIGNAL VOLTAGE HIGH: OPENING LOW)**

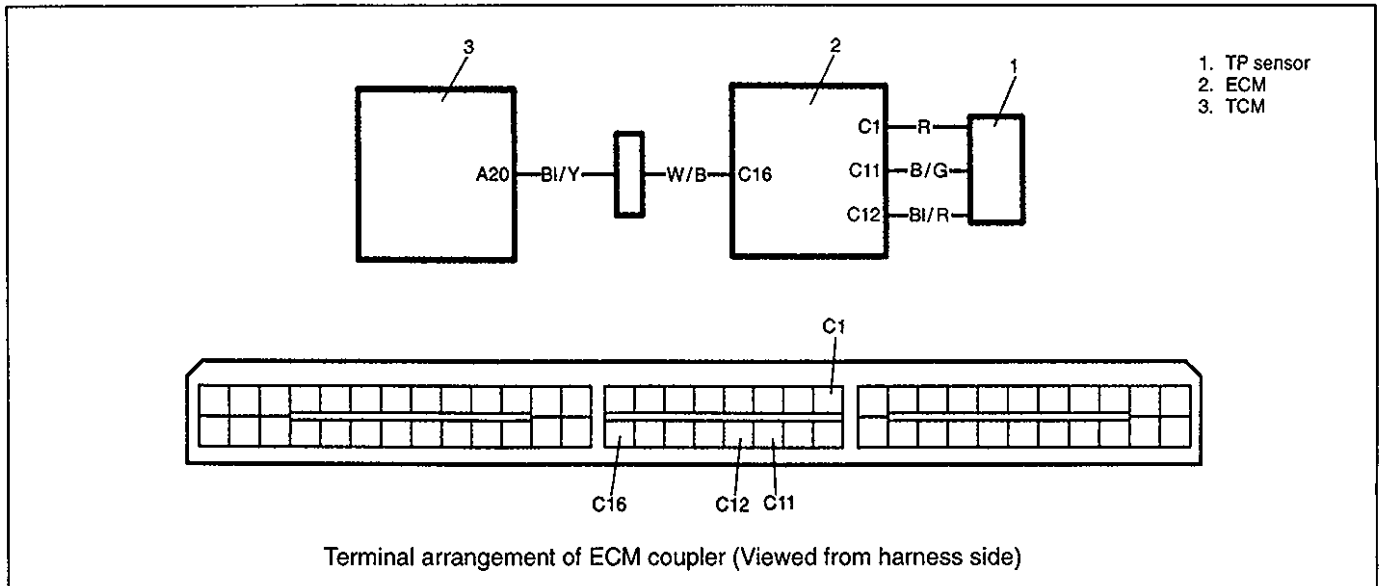

```

    graph TD
      Start[Check throttle opening signal referring to Section 6E3.  
Is it OK?] -- YES --> Intermittent[Intermittent trouble or faulty TCM.  
Recheck referring to "Intermittent and Poor Connection" on  
Section 0A.]
      Start -- NO --> DTC[Check diagnostic trouble code of electronic fuel injection  
system referring to Section 6E3.  
Does it indicate code No. 12?]
      Intermittent -- YES --> Voltage[1. Disconnect ECM couplers with ignition switch OFF.  
2. Turn ON ignition switch and check voltage between C16  
terminal of disconnected ECM coupler and body ground.  
3. Is it about 10 – 14 V?]
      Intermittent -- NO --> DTC
      DTC -- YES --> Voltage
      DTC -- NO --> Repair[Inspect and repair referring Section 6E3.]
      Voltage -- YES --> PoorB5[Poor B5 connection of ECM coupler.  
If connection is OK, substitute a known-good ECM and re-  
check.]
      Voltage -- NO --> PoorO[Poor "O" wire open or poor B8 connection of TCM coupler.  
If wire and connection are OK, substitute a known-good  
TCM and recheck.]
  
```

### DTC 34 – TRANSMISSION RANGE SWITCH CIRCUIT

(MORE THAN TWO SHIFT SWITCH SIGNALS INPUTTED OR SHIFT SWITCH SIGNAL NOT INPUTTED AT VEHICLE RUNNING)

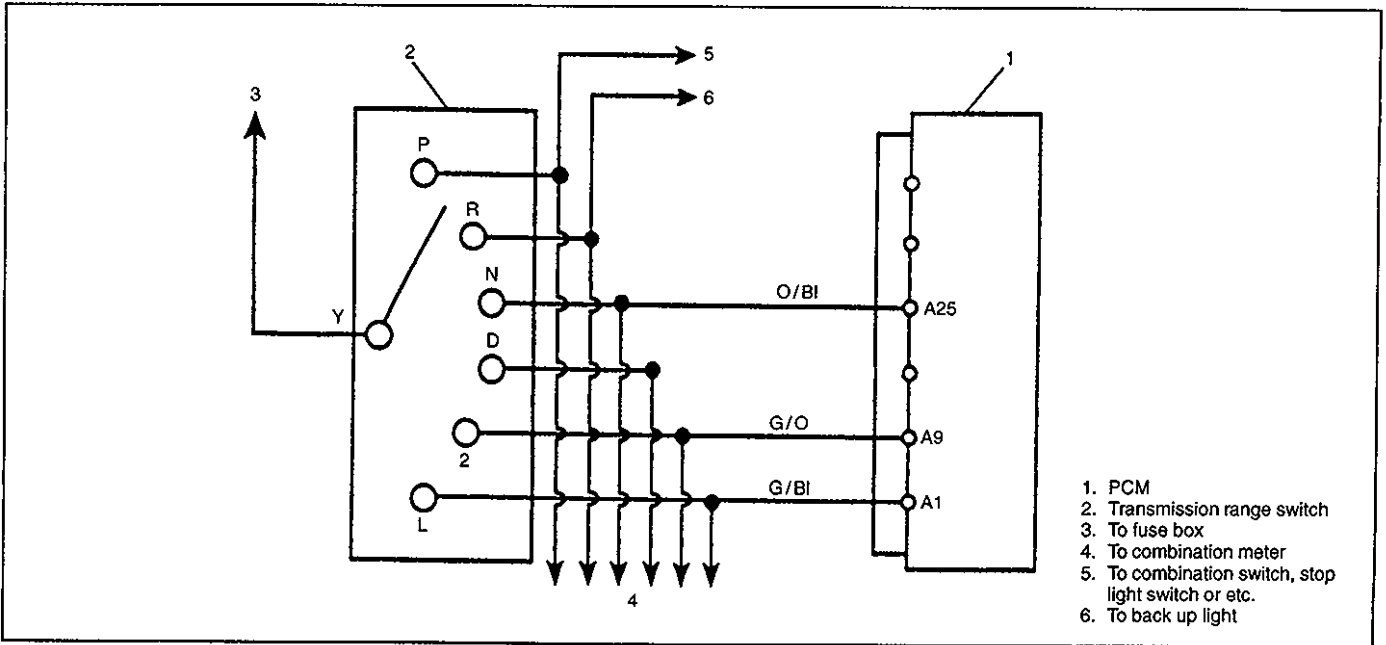

Measure voltage between each TCM terminal of "A1", "A9" and "A25" and body ground with ignition switch ON and under following conditions.

Terminal	Standard voltage (condition)	
"N"	10 – 14 V (N range)	0 – 1 V (other than N range)
"2"	10 – 14 V (2 range)	0 – 1 V (other than 2 range)
"L"	10 – 14 V (L range)	0 – 1 V (other than L range)

Are all above OK?

NO

YES

Check transmission range switch referring to "ON-VEHICLE SERVICE" in the same section of service manual mentioned in FOREWORD of this manual. Is it in good condition?

Poor TCM coupler connection. If connection are OK, intermittent trouble or faulty TCM. Recheck for intermittent trouble referring to "Intermittent and Poor Connection" in Section 0A.

YES

NO

Transmission range switch or connection faulty.

Faulty or maladjusted transmission range switch.

### DTC 36 – VEHICLE SPEED SENSOR (A/T and Meter) (VEHICLE SPEED SIGNAL NOT INPUTTED)

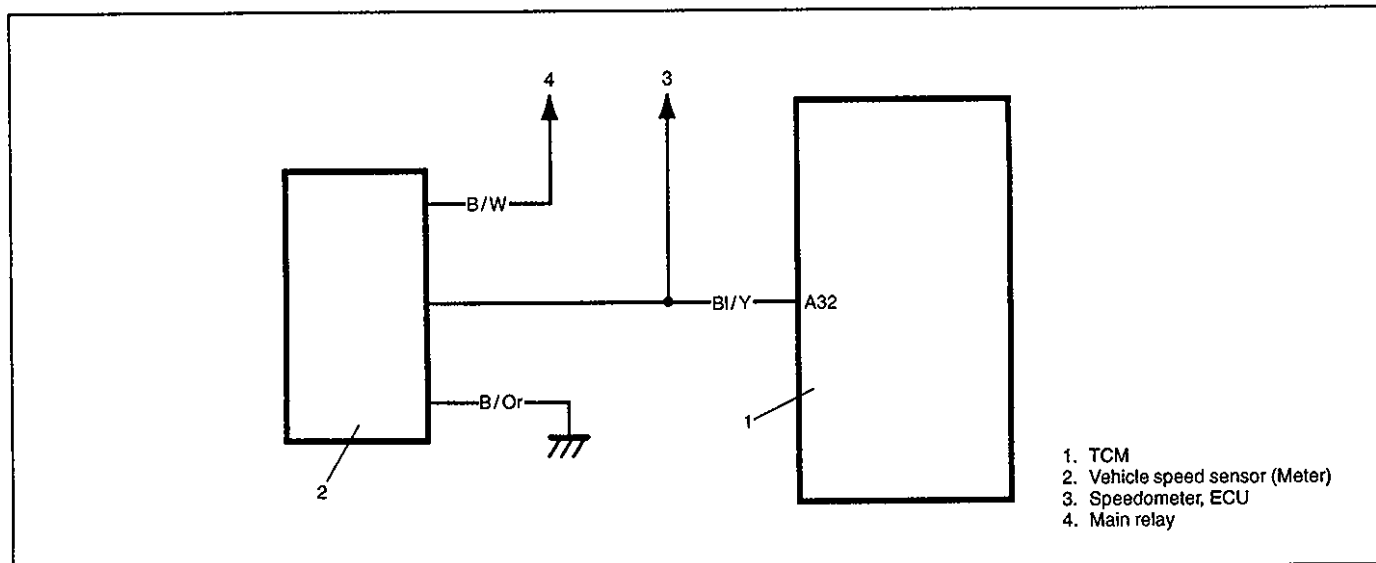

- Vehicle speed sensor (A/T)  
Refer to item DTC-31 in this section.
- Vehicle speed sensor (Meter)

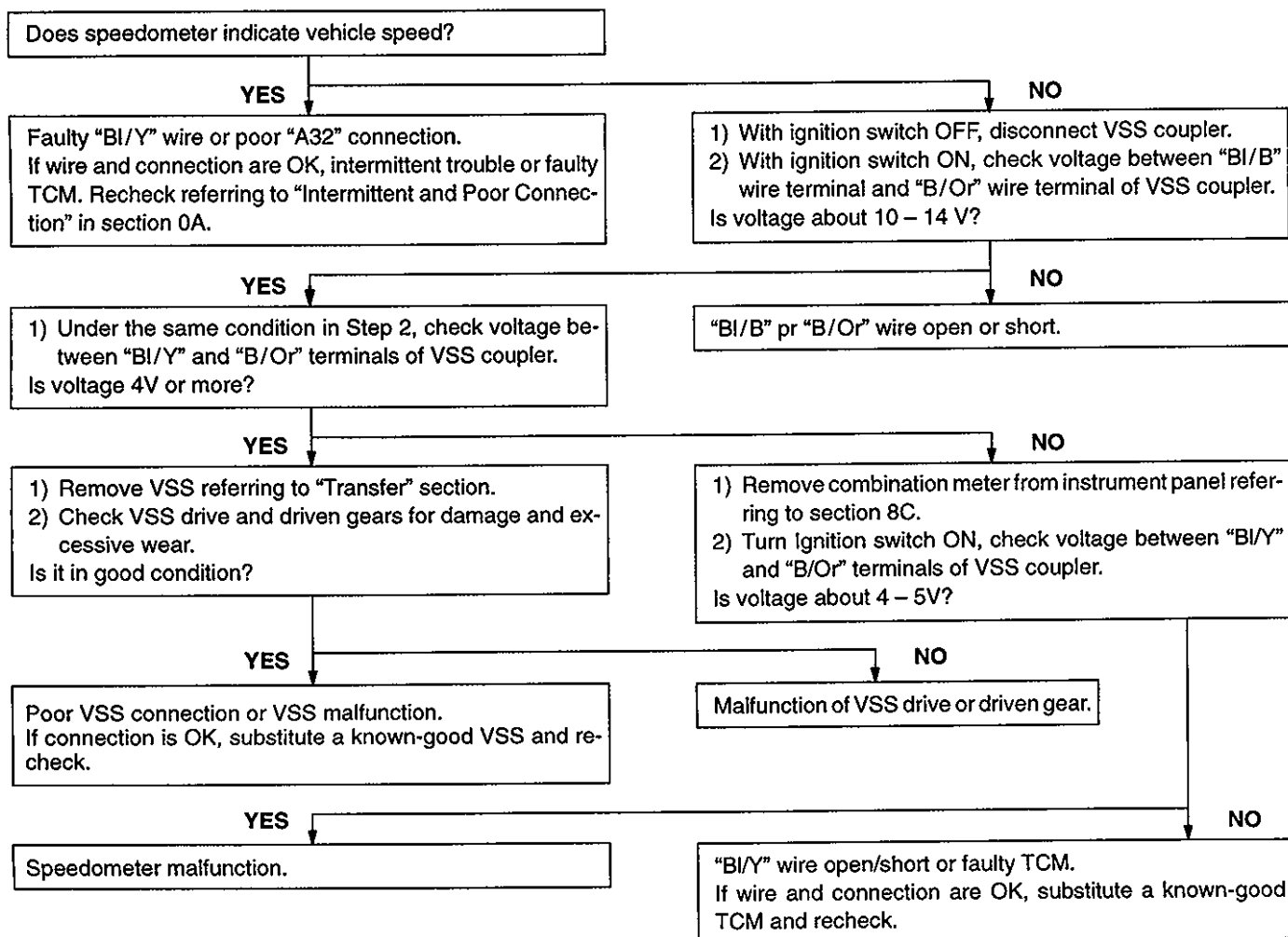

## DTC 51 – ENGINE COOLANT TEMP. SIGNAL (ENGINE COOLANT TEMP. SIGNAL IS HIGH, OR LOW TEMP. SIGNAL INPUTTED FOR 15 MIN. WHILE ENGINE RUNNING.)

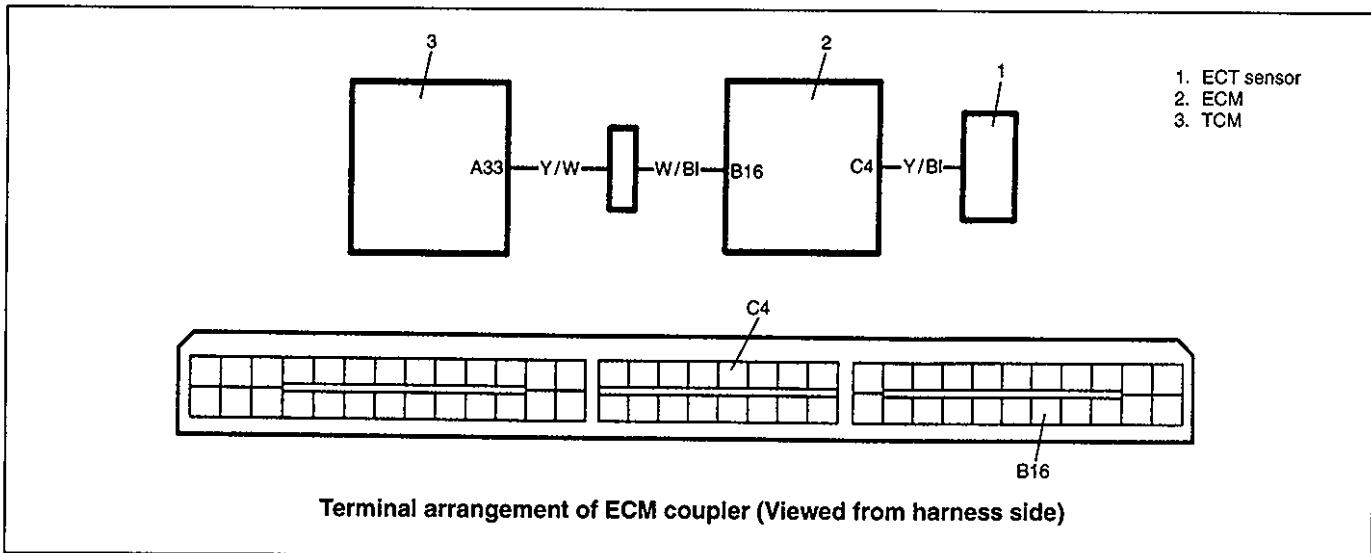

Check engine coolant temp. signal referring to Section 6E3.  
Is it OK?

YES

Intermittent trouble or faulty TCM.  
Recheck referring to "Intermittent trouble" on Section 0B.

NO

Check diagnostic trouble code of electronic fuel injection system referring to Section 6E3.  
Does it indicate code No. 12?

YES

1. Disconnect ECM couplers with ignition switch OFF.  
2. Turn ON ignition switch and check voltage between B16 terminal of disconnected ECM coupler and body ground.  
3. Is it about 12 V?

NO

Inspect and repair referring to diagnostic trouble code flow chart of electronic fuel injection system in Section 6E3.

YES

Poor B16 connection of ECM coupler.  
If connection is OK, substitute a known-good ECM and recheck.

NO

"Y/W" and/or "W/BI" wire open, shorted to ground or poor B15 connection of TCM coupler.  
If wire and connection are OK, substitute a known-good TCM and recheck.

## ON-VEHICLE SERVICE

### FLUID CHANGE

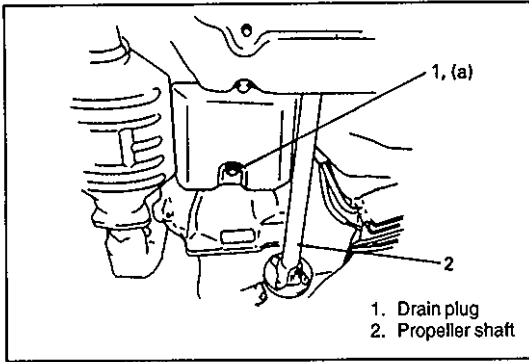

- 1) Lift up vehicle.
- 2) With engine in cold condition, remove drain plug from oil pan and drain A/T fluid.
- 3) Install drain plug.

#### Tightening Torque

(a): 23 N·m (2.3 kg·m, 17.0 lb·ft)

- 4) Lower vehicle and fill proper amount of an equivalent of DEXRON®-II, DEXRON®-IIE or DEXRON®-III.
- 5) Check fluid level according to procedure described under LEVEL CHECK AT NORMAL OPERATING TEMPERATURE.

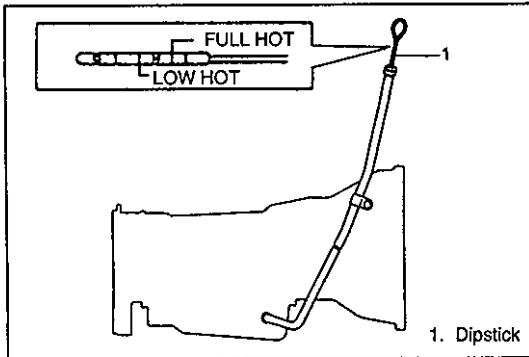

Fluid specification	
An equivalent of DEXRON®-II, DEXRON®-IIE or DEXRON®-III	
Fluid capacity	
When draining from drain plug hole	2.5 liters (5.28/4.40 US/Imp.pt.)
When overhauling	6.9 liters (14.58/12.14 US/Imp. pt.) (RF engine)

### THROTTLE POSITION (TP) SENSOR INSPECTION AND ADJUSTMENT

Refer to Section 6E3.

**REMountING:****WARNING:**

When moving transmission assembly with torque converter equipped in it, be sure to keep it horizontal. Tilting it with its front facing down may allow converter to fall off, whereby an injury may result.

For remounting, reverse dismounting procedure. Use specified torque as given below and left.

Tightening torque	N·m	kg·m	lb·ft
<ul style="list-style-type: none"> <li>● Exhaust No.1 pipe to manifold bolts</li> <li>● Muffler to exhaust No.2 pipe nuts</li> </ul>	60	6.0	43.0
Case left and right stiffener bolts	50	5.0	36.5
Universal joint flange bolts and nuts	50	5.0	36.5
<ul style="list-style-type: none"> <li>● Oil filler tube bolts</li> <li>● Select cable bracket bolts</li> </ul>	23	2.3	16.5

- Clamp wiring harness and hoses securely.
- Adjust select cable.
- Refer to page 7B1-45 of SQ416/420/625 Service Manual (99500-65D00) for tuning of A/T throttle cable.
- Follow fluid level check procedure in page 7B1-44 of SQ416/420/625 Service Manual (99500-65D00) for refilling automatic transmission fluid and its level adjusting.
- Connect battery, and confirm that engine and transmission function acceptably.
- When remounting drive plate, use specified bolts.

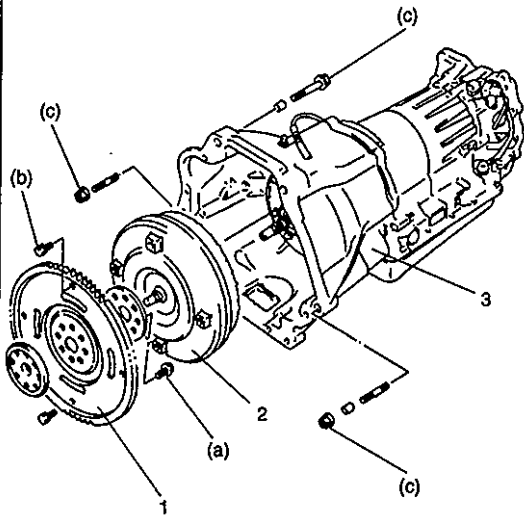
**Tightening Torque**

- (a): 100 N·m (10.0 kg·m, 72.5 lb·ft)  
 (b): 65 N·m (6.5 kg·m, 47.0 lb·ft)  
 (c): 85 N·m (8.5 kg·m, 61.5 lb·ft)

1. Drive plate
2. Torque converter
3. Automatic transmission

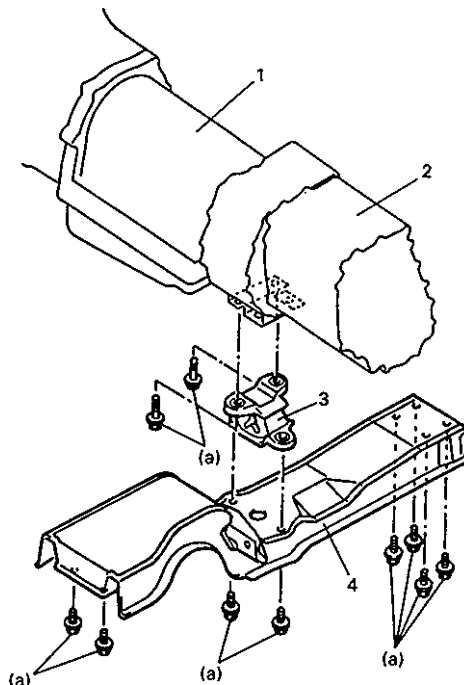
**Tightening Torque**

- (a): 50 N·m (5.0 kg·m, 36.5 lb·ft)

1. Automatic transmission
2. Transfer
3. Engine rear mounting
4. Engine rear mounting member

## UNIT REPAIR

Refer to the same section of UNIT REPAIR MANUAL mentioned in Foreword of this manual and follow the procedure applicable to "H25 engine". But use the following values for step 33) of UNIT ASSEMBLY described in 7B1-57.

Used for	Spring outer diameter	Spring free length	
Direct clutch accumulator	31.80 – 31.85 mm (1.252 – 1.254 in.)	Upper	43.56 mm (1.715 in.)
		Lower	30.00 mm (1.18 in.)
Forward clutch accumulator		Upper	64.68 mm (2.546 in.)
		Lower	—————
Second brake accumulator	34.80 – 34.85 mm (1.370 – 1.372 in.)	Upper	55.18 mm (2.172 in.)
		Lower	35.13 mm (1.383 in.)

## TIGHTENING TORQUE SPECIFICATIONS

Fastening portion		Tightening torque		
		N·m	kg·m	lb·ft
<b>ON-VEHICLE SERVICE</b>	Automatic transmission fluid drain plug Oil filler tube bolts Select cable bracket bolts	23	2.3	17.0
	Exhaust No. 1 pipe to manifold bolts Muffler to exhaust No. 2 pipe nuts	60	6.0	43.0
	Case left and right stiffener bolts	50	5.0	36.5
	Universal joint flange bolts and nuts			
	Transmission to engine bolts and nut	85	8.5	61.5
	Drive plate bolts	65	6.5	47.0
	Drive plate flange bolts	100	10.0	72.5

## REQUIRED SERVICE MATERIALS

MATERIAL	RECOMMENDED SUZUKI PRODUCT	USE
A/T fluid	An equivalent of DEXRON®-II, DEXRON®-IIE or DEXRON®-III	<ul style="list-style-type: none"> <li>● Automatic transmission</li> <li>● Parts lubrication when installing</li> </ul>

## SPECIAL TOOL

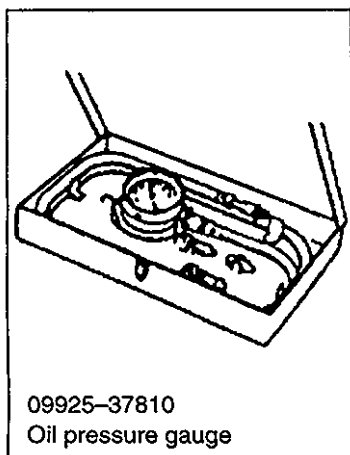

## SECTION 7C1

## CLUTCH

## NOTE:

For the descriptions (items) not found in this section, refer to the same section of the Service Manual mentioned in FOREWORD of this manual.

## CONTENTS

<b>UNIT REPAIR</b> .....	7C1- 1
Clutch Cover, Clutch Disc and Flywheel .....	7C1- 1
<b>TIGHTENING TORQUE SPECIFICATIONS</b> .....	7C1- 4
<b>REQUIRED SERVICE MATERIALS</b> .....	7C1- 4
<b>SPECIAL TOOLS</b> .....	7C1- 4

## UNIT REPAIR

## CLUTCH COVER, CLUTCH DISC AND FLYWHEEL

## DISMOUNTING/REMountING

Refer to SECTION 7A "Dismounting/Remounting of Trans Unit".

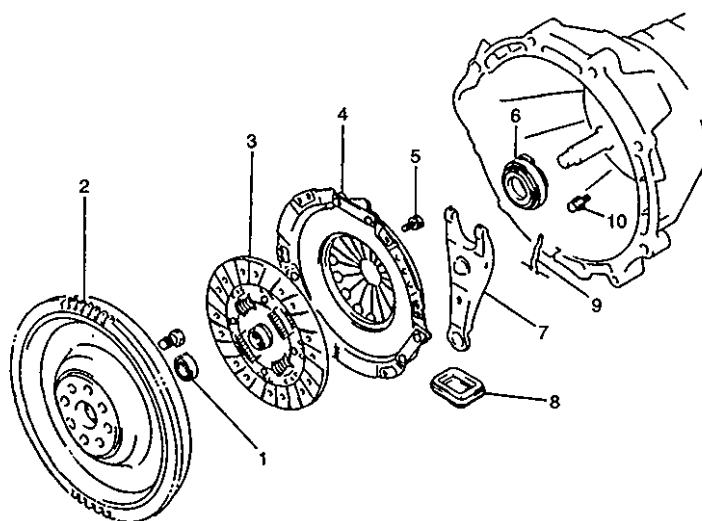

1. Input shaft bearing
2. Flywheel
3. Clutch disc
4. Clutch cover
5. Bolt
6. Release bearing
7. Clutch release fork
8. Boot
9. Clip
10. Clutch release fork support

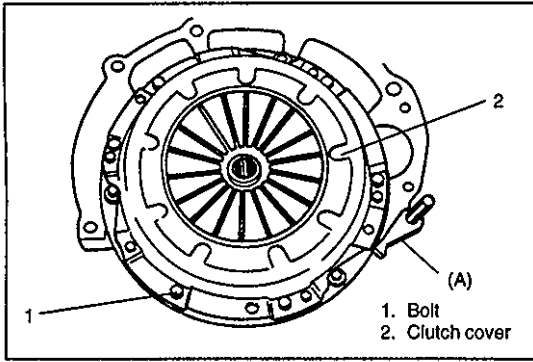
**REMOVAL**

- 1) Hold flywheel stationary with special tool (A) and remove clutch cover bolts, clutch cover and clutch disc.

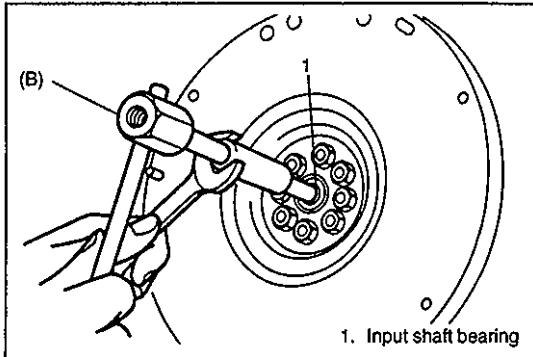
**Special Tool****(A): 09924-17810**

- 2) Pull out input shaft bearing by using special tool (B) and wrench.

**Special Tool****(B): 09923-73210**

- 3) Remove release bearing and release fork.

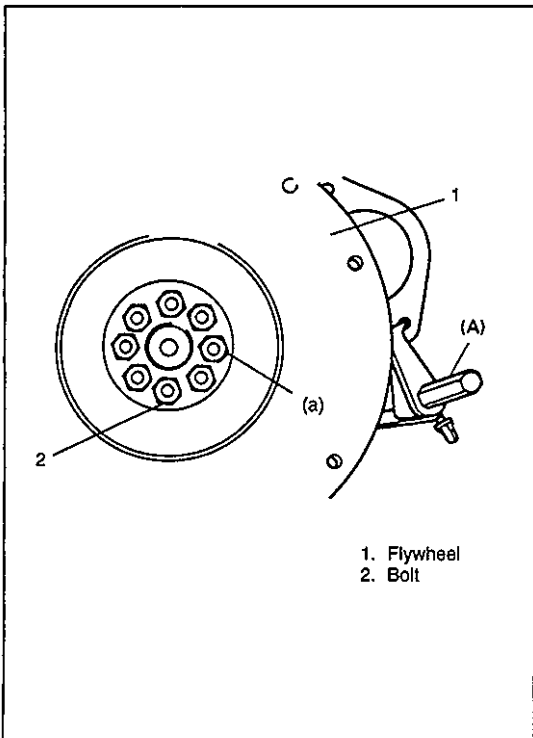
**INSTALLATION****NOTE:**

**Before assembling, make sure that flywheel surface and pressure plate surface have been cleaned and dried thoroughly.**

- 1) Install flywheel to crankshaft and tighten bolts to specification.

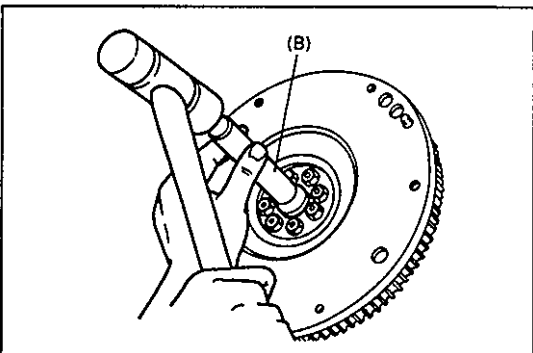
**Special Tool****(A): 09924-17810****Tightening Torque****(a): 170 N·m (17.0 kg-m, 123 lb-ft)**

- 2) Using special tool (B), install input shaft bearing to flywheel.

**Special Tool****(B): 09925-98210**

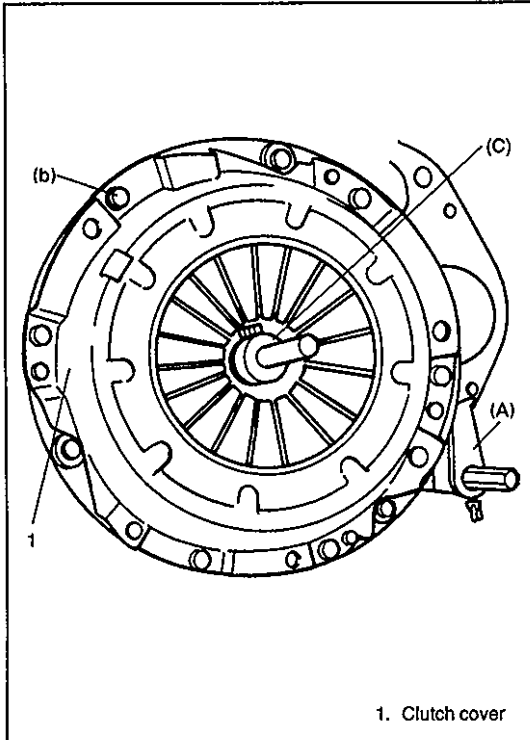

- 3) Aligning clutch disc to flywheel center by using special tool (C), install clutch cover and bolts. Then tighten bolts to specification.

**NOTE:**

- While tightening clutch cover bolts, compress clutch disc with special tool (C) by hand so that disc centered.
- Tighten cover bolts little by little evenly in diagonal order.

**Special Tools**

(A): 09924-17810

(C): 09923-36320

**Tightening Torque**

(b): 23 N·m (2.3 kg·m, 16.5 lb-ft)

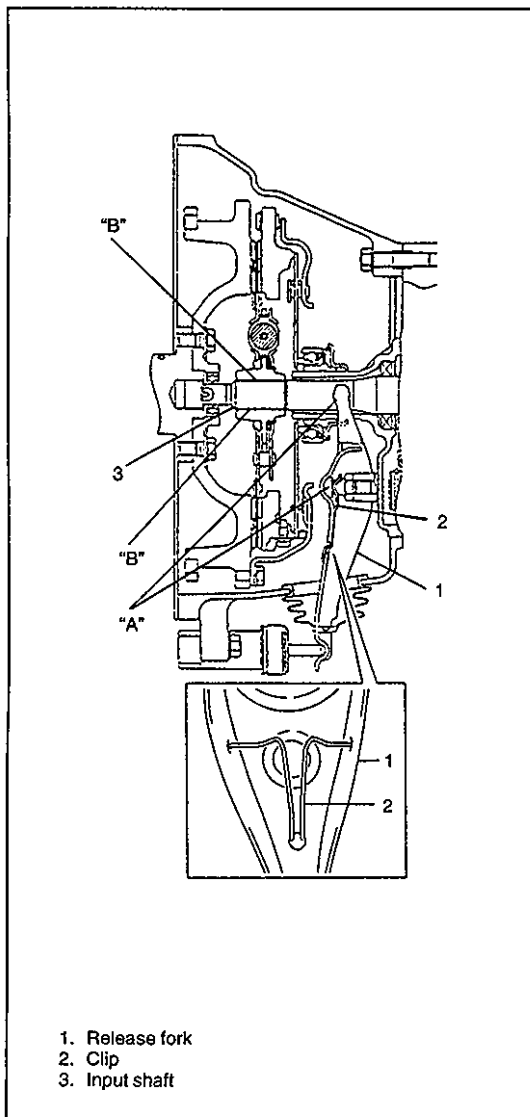

- 4) Install clip to release fork and apply grease.

“A”: Grease 99000-25010

Then install release fork and release bearing as shown in figure.

- 5) Slightly apply grease to input shaft and install clutch disc. Then join transmission transfer assembly with engine. Refer to SECTION 7A.

“B”: Grease 99000-25210

**NOTE:**

Turn crankshaft with wrench from front while inserting transmission input shaft to clutch disc until splines mesh.

## TIGHTENING TORQUE SPECIFICATIONS

Fastening portion	Tightening torque		
	N·m	kg·m	lb·ft
Flywheel bolts	170	17.0	123
Clutch cover bolts	23	2.3	16.5

## REQUIRED SERVICE MATERIALS

MATERIAL	RECOMMENDED SUZUKI PRODUCT	USE
Lithium grease	SUZUKI SUPER GREASE A (99000-25010)	<ul style="list-style-type: none"> <li>● Clutch master cylinder clevis pin.</li> <li>● Release fork.</li> <li>● Push rod tip of operating cylinder.</li> </ul>
	SUZUKI SUPER GREASE I (99000-25210)	Input shaft spline front end.
Clutch fluid (Brake fluid)	DOT3 or SAE J1703	<ul style="list-style-type: none"> <li>● Clutch reservoir.</li> <li>● Clutch master cylinder.</li> <li>● Clutch operating cylinder.</li> </ul>

## SPECIAL TOOLS

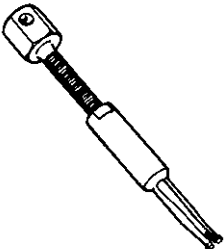
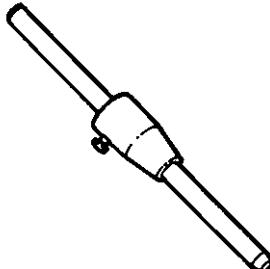
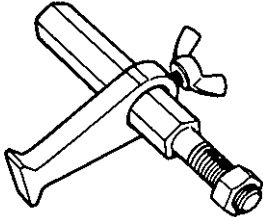
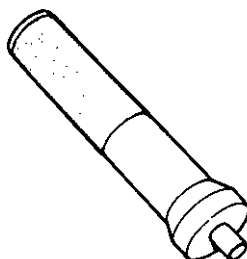
 <p>09923-73210 Bearing remover</p>	 <p>09923-36320 Clutch center guide</p>	 <p>09924-17810 Flywheel holder</p>	 <p>09925-98210 Input shaft bearing installer</p>
--	--	---	--

## SECTION 7F

## DIFFERENTIAL (REAR)

## NOTE:

For the descriptions (items) not found in this section, refer to the same section of the Service Manual mentioned in FOREWORD of this manual.

## CONTENTS

GENERAL DESCRIPTION ..... 7F- 1

## GENERAL DESCRIPTION

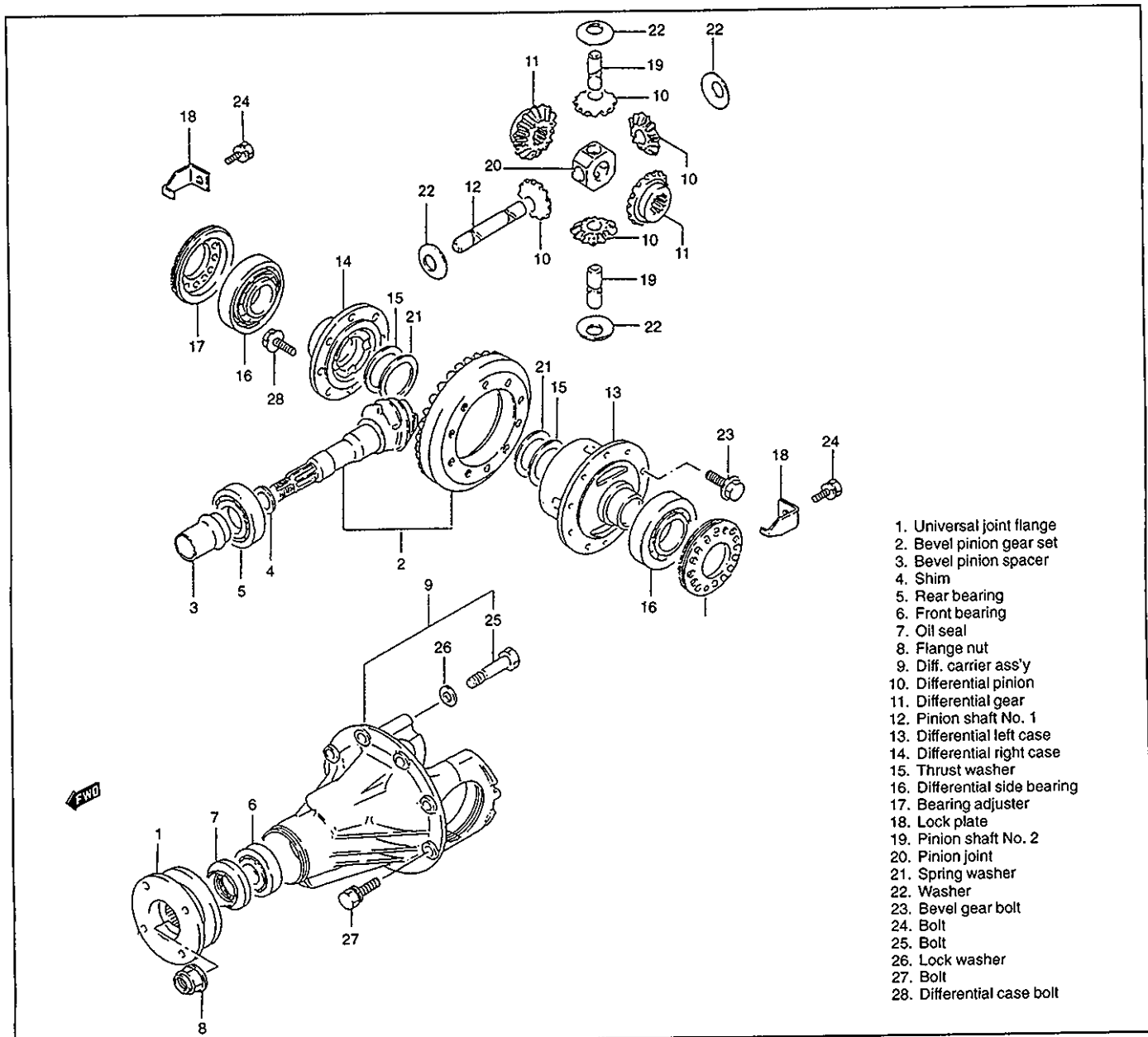

## SECTION 8C

## INSTRUMENTATION/DRIVER INFORMATION

**WARNING:**

For vehicles equipped with Supplemental Restraint (Air Bag) System

- Service on and around the air bag system components or wiring must be performed only by an authorized SUZUKI dealer. Refer to "Air Bag System Components and Wiring Location View" under "General Description" in air bag system section in order to confirm whether you are performing service on or near the air bag system components or wiring. Please observe all WARNINGS and "Service Precautions" under "On-Vehicle Service" in air bag system section before performing service on or around the air bag system components or wiring. Failure to follow WARNINGS could result in unintentional activation of the system or could render the system inoperative. Either of these two conditions may result in severe injury.
- Technical service work must be started at least 90 seconds after the ignition switch is turned to the "LOCK" position and the negative cable is disconnected from the battery. Otherwise, the system may be activated by reserve energy in the Sensing and Diagnostic Module (SDM).

**NOTE:**

For the descriptions (items) not found in this section of this manual, refer to the same section of Service Manual mentioned in the FOREWORD of this manual.

## CONTENTS

<b>GENERAL DESCRIPTION</b> .....	8C- 2
Combination Meter .....	8C- 2
<b>ON-VEHICLE SERVICE</b> .....	8C- 3
Fuel Gauge .....	8C- 3
Engine Coolant Temp. ....	8C- 3
Oil Pressure Light .....	8C- 4

# GENERAL DESCRIPTION

## COMBINATION METER

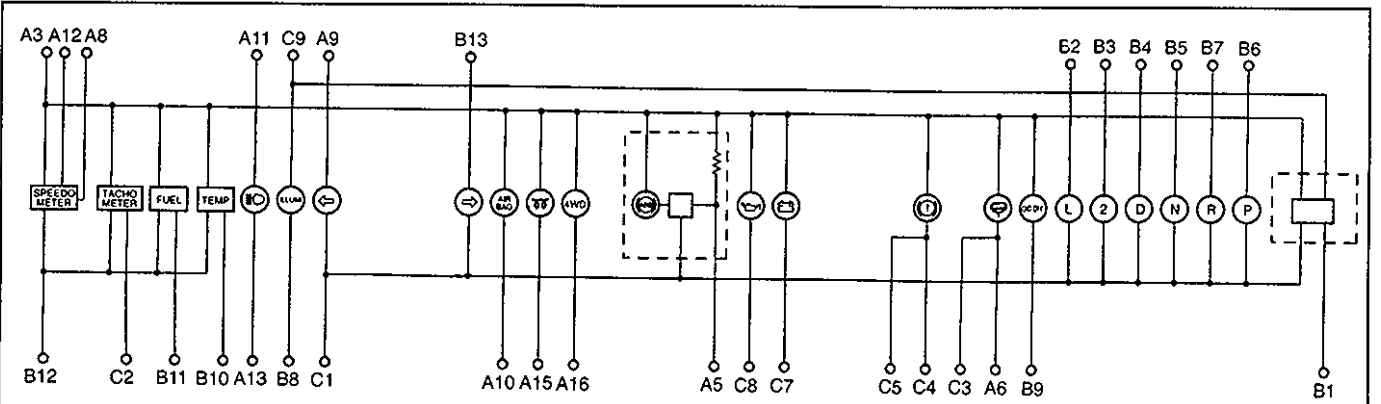
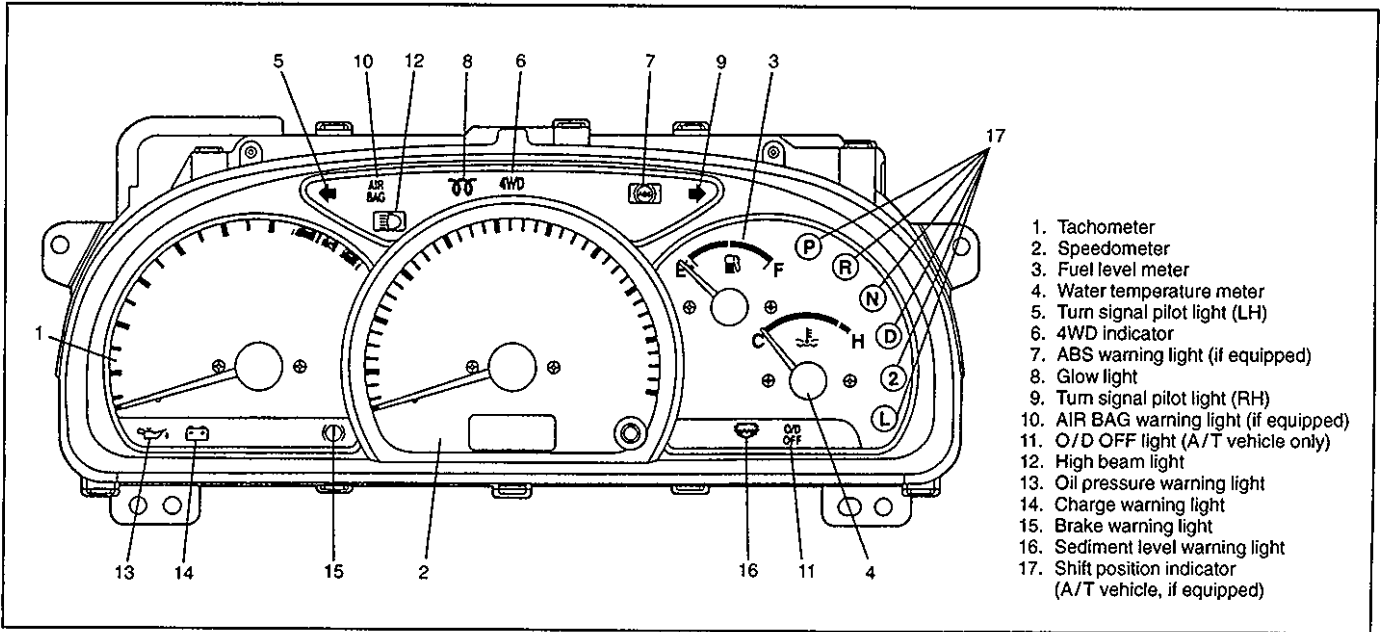

**NOTE:**  
Terminal arrangement of coupler viewed from harness side.

### Coupler A

### Coupler B

### Coupler C

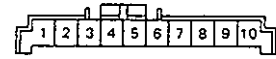
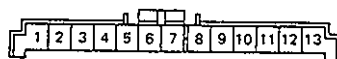

### Coupler A

- |                             |       |
|-----------------------------|-------|
| 1. Blank                    | ---   |
| 2. Blank                    | ---   |
| 3. To ignition switch       | B/W   |
| 4. Blank                    | ---   |
| 5. To ABS control module    | Bl/Or |
| 6. To sediment level switch | Gr/Bl |
| 7. Blank                    | ---   |
| 8. To VSS                   | Bl/Y  |
| 9. To combination switch    | G/R   |
| 10. To SDM                  | Y/G   |
| 11. To main fuse            | W/Bl  |
| 12. To fuse box             | W     |
| 13. To combination switch   | R     |
| 14. Blank                   | ---   |
| 15. To ECM                  | V/Y   |
| 16. To 4WD controller       | Or/B  |

### Coupler B

- |   |       |
|---|-------|
| 1. To door switch (driver side)                   | B/Bl  |
| 2. To shift switch (A/T vehicle only) L           | G/Bl  |
| 3. To shift switch (A/T vehicle only) 2           | G/Or  |
| 4. To shift switch (A/T vehicle only) D           | Y/G   |
| 5. To shift switch (A/T vehicle only) N           | Or/Bl |
| 6. To shift switch (A/T vehicle only) P           | Or/G  |
| 7. To shift switch (A/T vehicle only) R           | R     |
| 8. To ground                                      | B     |
| 9. Transmission control module (A/T vehicle only) | W/B   |
| 10. To ECT sensor                                 | Y/W   |
| 11. To fuel level gauge                           | Bl/W  |
| 12. To ground                                     | B/Y   |
| 13. To combination switch                         | G/Y   |

### Coupler C

- |                                |     |
|--------------------------------|-----|
| 1. To ground                   | B   |
| 2. To ECM                      | Br  |
| 3. To ignition switch          | V/R |
| 4. To brake fluid level switch | R/B |
| 5. To parking brake switch     | V   |
| 6. Blank                       | --- |
| 7. To generator                | W/R |
| 8. To oil pressure switch      | Y/B |
| 9. To combination switch       | R/Y |
| 10. Blank                      | --- |

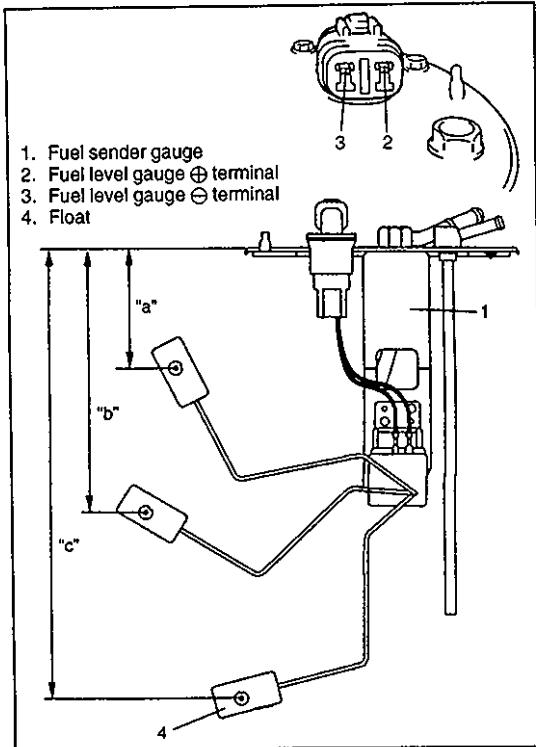

## FUEL METER/FUEL GAUGE UNIT

### FUEL SENDER GAUGE

#### INSPECTION

Remove fuel sender gauge referring to Section 6C of this manual. Use an ohmmeter to confirm that resistance of sender gauge unit changes with change of float position.

Float Position	Fuel Meter	Resistance (Ω)
"a"	F	6 – 8
"b"	1/2	29.5 – 35.5
"c"	E	94 – 96

If measured value is out of specification, replace fuel sender gauge.

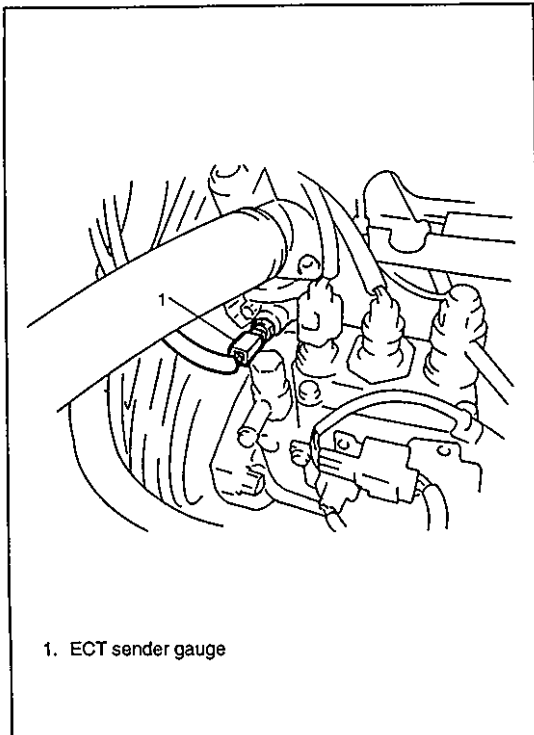

## ENGINE COOLANT TEMP. (ECT) METER AND SENSOR

### ENGINE COOLANT TEMP. SENDER GAUGE

#### REMOVAL AND INSTALLATION

Remove and install ECT sender gauge noting the followings.

- Clean mating surface of ECT sender gauge and thermostat case.
- Apply sealant to ECT sender gauge matching surface.
- Tighten ECT sender gauge to specified torque.

#### Tightening Torque

8 Nm. (0.8 kg – m, 6.0 lb-ft)

- Connect coupler to gauge securely.

#### INSPECTION

Warm up sender gauge. Thus make sure its resistance is decreased with increase of its temperature.

Temperature	Resistance
50°C (122°F)	136 – 216 Ω
120°C (248°F)	16.4 – 19.4 Ω

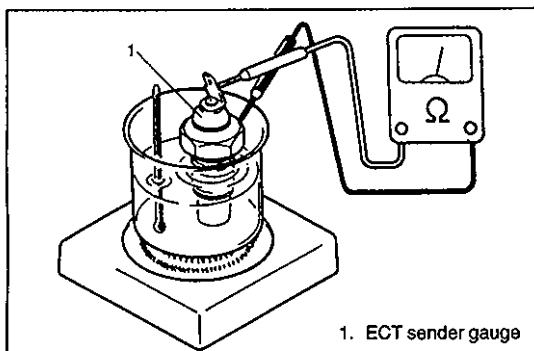

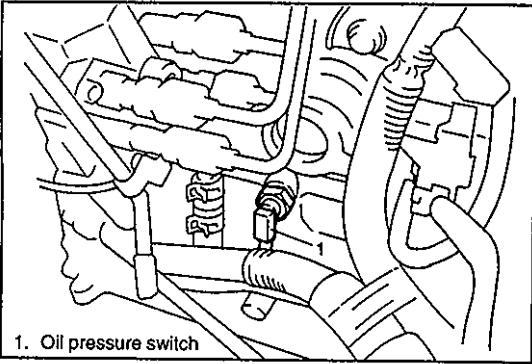

## OIL PRESSURE LIGHT

### OIL PRESSURE SWITCH

#### REMOVAL AND INSTALLATION

Refer to OIL PRESSURE CHECK in Section 6A3 of this manual for details.

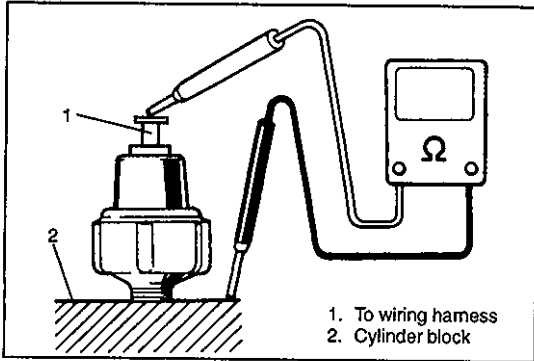

#### INSPECTION

Use an ohmmeter to check switch continuity.

During Engine Running	No continuity ( $\infty \Omega$ )
At Engine Stop	Continuity ( $0 \Omega$ )

## SECTION 8G

# IMMOBILIZER CONTROL SYSTEM (IF EQUIPPED)

**WARNING:**

For vehicles equipped with Supplemental Restraint (Air Bag) System

- Service on and around the air bag system components or wiring must be performed only by an authorized SUZUKI dealer. Refer to "Air Bag System Components and Wiring Location View" under "General Description" in air bag system section in order to confirm whether you are performing service on or near the air bag system components or wiring. Please observe all WARNINGS and "Service Precautions" under "On-Vehicle Service" in air bag system section before performing service on or around the air bag system components or wiring. Failure to follow WARNINGS could result in unintentional activation of the system or could render the system inoperative. Either of these two conditions may result in severe injury.
- Technical service work must be started at least 90 seconds after the ignition switch is turned to the "LOCK" position and the negative cable is disconnected from the battery. Otherwise, the system may be activated by reserve energy in the Sensing and Diagnostic Module (SDM).

**NOTE:**

For the descriptions (items) not found in this section, refer to the same section of the Service Manual mentioned in FOREWORD of this manual.

## CONTENTS

GENERAL DESCRIPTION ..... 8G- 1

## GENERAL DESCRIPTION

The immobilizer control system of this vehicle use glow light as malfunction indicator lamp.

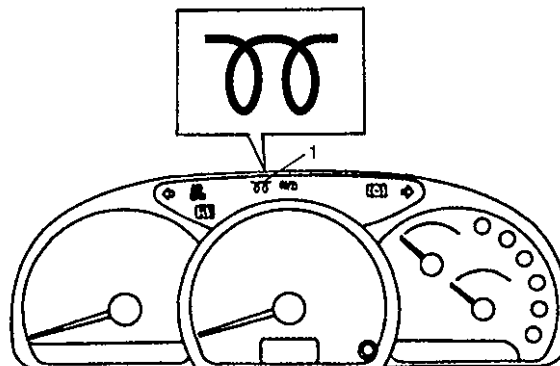

1. Malfunction indicator lamp (Glow light)

# SECTION 10

## SERVICE DATA

### CONTENTS

ENGINE .....	10- 1
LUBRICATION SYSTEM .....	10- 5
COOLING SYSTEM .....	10- 5
ENGINE ELECTRICAL SYSTEM .....	10- 6
AIR CONDITIONING SYSTEM .....	10- 6

### ENGINE

ITEM		SPECIFICATION
Cylinder Arrangement and Number		In-line, 4-cylinders
Firing Order		1 - 3 - 4 - 2
Valve System		OHC, belt-driven
Bore Stroke [mm (in.)]		86.0 × 86.0 (3.39 × 3.39)
Total Piston Displacement [cc (cu in.)]		1,998 (121.9)
Compression Ratio		20.4 : 1
Compression Pressure [kg/cm <sup>2</sup> (psi)-rpm]	Standard	30 (427)-200
	Minimum	27 (384)-200
	Maximum Difference Between Cylinders	3.0 (43)
Injection Timing		13° [ATDC]
Injection Pressure [kg/cm <sup>2</sup> (psi)]		150 (2133)
Idle Speed [rpm]		720—820 ( P range (A/T), Neutral (M/T) )
<b>Valve Timing</b>		
Intake	Open [BTDC]	13°
	Close [ABDC]	31°
Exhaust	Open [BBDC]	60°
	Close [ATDC]	8°
Valve Clearance [mm (in.)]	IN	Cold: 0.25 ± 0.05 (0.010 ± 0.002) Warm: 0.30 (0.012)
	EX	Cold: 0.35 ± 0.05 (0.014 ± 0.002) Warm: 0.40 (0.016)

ITEM		SPECIFICATION	
<b>Valve Guide, Valve and Valve Spring</b>			
Valve Stem to Guide Clearance [mm (in.)]	IN	0.040 – 0.075 (0.0016 – 0.0029)	
	EX	0.045 – 0.080 (0.0018 – 0.0031)	
	Maximum	0.1 (0.004)	
Valve Stem Diameter [mm (in.)]	IN	7.970 – 7.985 (0.3138 – 0.3143)	
	EX	7.965 – 7.980 (0.3136 – 0.3141)	
	Maximum	IN: 7.920 (0.312) EX: 7.915 (0.311)	
Valve Head Diameter [mm (in.)]	IN	38.85 – 39.55 (1.529 – 1.527)	
	EX	34.95 – 35.25 (1.375 – 1.387)	
Valve Face Angle	IN	30°	
	EX	45°	
Valve Spring out-of-Square Limit [mm (in.)]		1.57 (0.062) max.	
Valve Spring Free Length [mm (in.)]	Standard	45.11 (1.776)	
	Minimum	44.80 (1.764)	
<b>Cylinder Head and Valve Seat</b>			
Distortion [mm (in.)]		0.10 (0.004) max.	
Seat Angle	IN	30°	
	EX	45°	
Seat Contact Width [mm (in.)]	IN	1.4 – 1.8 (0.056 – 0.070)	
	EX	1.64 – 2.04 (0.065 – 0.080)	
Seat Sinking (Measure Valve Recession) [mm (in.)]	IN	Standard	0.75 – 1.05 (0.030 – 0.041)
		Maximum	1.55 (0.061)
	EX	Standard	0.75 – 1.05 (0.030 – 0.041)
		Maximum	1.55 (0.061)
Tappet Outer Diameter [mm (in.)]		34.959 – 34.965 (1.37634 – 1.37657)	
Tappet Hole Diameter [mm (in.)]		34.990 – 35.010 (1.37756 – 1.37834)	
Tappet to Tappet Hole Clearance [mm (in.)]	Standard	0.025 – 0.061 (0.00099 – 0.00240)	
	Maximum	0.10 (0.004)	
Adjusting Disc		25 different thicknesses from 3.40 mm (0.13 in.) to 4.30 mm (0.17 in.)	
<b>Camshaft</b>			
Camshaft Runout (Deflection) [mm (in.)]		0.10 (0.004) max.	
Camshaft End Play [mm (in.)]	Standard	0.02 – 0.18 (0.0008 – 0.0071)	
	Maximum	0.20 (0.008)	
Journal Diameter [mm (in.)]	Standard	31.959 – 31.975 (1.2583 – 1.2588)	
	Out-of-round	0.05 (0.002) max.	
Camshaft Bearing Oil Clearance [mm (in.)]	Standard	0.025 – 0.066 (0.0010 – 0.0025)	
	Maximum	0.10 (0.004)	
Camshaft Lobe Height [mm (in.)]	IN	Standard	43.792 (1.7241)
		Minimum	42.110 (1.6579)
	EX	Standard	45.300 (1.7835)
		Minimum	44.900 (1.7677)

ITEM		SPECIFICATION	
Valve Lift [mm (in.)]	IN	7.5 (0.30)	
	EX	9.0 (0.35)	
<b>Connecting Rod and Connecting Rod Bearing</b>			
Length (Center to center) [mm (in.)]		151.95 – 152.05 (5.9823 – 5.9862)	
Maximum Bending [mm (in.)]		0.16 (0.0063) per 100 (3.937)	
Small End Bushing Inner Diameter [mm (in.)]		30.014 – 30.030 (1.1817 – 1.1822)	
Big End Bore [mm (in.)]		54.002 – 54.017 (2.1261 – 2.1266)	
Big End Width [mm (in.)]		25.900 – 26.100 (1.0197 – 1.0275)	
Connecting Rod Side Clearance [mm (in.)]	Standard	0.110 – 0.262 (0.0044 – 0.0103)	
	Maximum	0.35 (0.014)	
Bearing Under Size [mm (in.)]		0.25 (0.010), 0.50 (0.020), 0.75 (0.030)	
<b>Crankshaft and Bearing</b>			
Crankshaft Runout [mm (in.)]		0.05 (0.002) max.	
End Play [mm (in.)]	Standard	0.04 – 0.282 (0.002 – 0.011)	
	Maximum	0.30 (0.012)	
Crankpin Diameter [mm (in.)]	Standard size	Standard	50.940 – 50.955 (2.0055 – 2.0060)
		Minimum	50.89 (2.004)
	0.25 (0.010) undersize	Standard	50.692 – 50.705 (1.9957 – 1.9962)
		Minimum	50.64 (1.994)
	0.50 (0.020) undersize	Standard	50.440 – 50.445 (1.9859 – 1.9864)
		Minimum	50.39 (1.984)
	0.75 (0.030) undersize	Standard	50.190 – 50.205 (1.9760 – 1.9765)
		Minimum	50.14 (1.974)
Main Journal Diameter [mm (in.)]	Standard size	Minimum	59.89 (2.358)
		0.25 (0.010) undersize	Standard
	Minimum		59.64 (2.348)
	0.50 (0.020) undersize	Standard	59.437 – 59.455 (2.3401 – 2.3407)
		Minimum	59.39 (2.338)
	0.75 (0.030) undersize	Standard	59.187 – 59.205 (2.3302 – 2.3309)
		Minimum	59.14 (2.328)
	Journal Rear Oil Sliding Surface Diameter [mm (in.)]		85.946 – 90.000 (3.384 – 3.543)
Main Journal Bearing Oil Clearance [mm (in.)]	Standard	0.031 – 0.050 (0.0013 – 0.0019)	
	Maximum	0.08 (0.0031)	
End Play [mm (in.)]	Standard	0.04 – 0.282 (0.002 – 0.011)	
	Maximum	0.30 (0.012)	

ITEM		SPECIFICATION
<b>Cylinder Block</b>		
Distortion [mm (in.)]		0.10 (0.004) max.
Cylinder Bore Diameter [mm (in.)]	Standard size	86.000 – 86.022 (3.3859 – 3.3866)
	0.25 (0.010) oversize	86.250 – 86.272 (3.3957 – 3.3965)
	0.50 (0.020) oversize	86.500 – 86.522 (3.4055 – 3.4063)
Cylinder Bore Taper and Out-of-round [mm (in.)]		0.022 (0.0009) max.
<b>Piston</b>		
Piston Diameter (Measured at 90° to pin bore axis and 19 mm (0.75 in) above the bottom of piston) [mm (in.)]	Standard size	85.957 – 85.983 (3.3842 – 3.3851)
	0.25 (0.010) oversize	86.207 – 86.233 (3.3940 – 3.3949)
	0.50 (0.020) oversize	86.457 – 86.483 (3.4039 – 3.4048)
Piston and Cylinder Clearance [mm (in.)]	Standard	0.032 – 0.065 (0.0013 – 0.0025)
	Maximum	0.15 (0.0059)
Clearance of Piston Ring to Ring Groove [mm (in.)]	Top	0.05 – 0.09 (0.0020 – 0.0035)
	Second	0.04 – 0.08 (0.0016 – 0.0031)
	Maximum	0.2 (0.008) (second ring)
Ring Groove Width in Piston [mm (in.)]	Top	2.17 – 2.19 (0.0855 – 0.0862)
	Second	2.03 – 2.05 (0.0780 – 0.0807)
	Oil	4.02 – 4.04 (0.1583 – 0.1590)
End Gap (Measured in the cylinder) [mm (in.)]	Top	0.20 – 0.40 (0.008 – 0.016)
	Second	0.20 – 0.40 (0.008 – 0.016)
	Oil (rail)	0.20 – 0.40 (0.008 – 0.016)
	Maximum	1.0 (0.039)
Piston Ring Oversize [mm (in.)]		0.25 (0.010), 0.50 (0.020)
Piston Oversize [mm (in.)]		0.25 (0.010), 0.50 (0.020)
Piston Pin Hole Diameter (in piston) [mm (in.)]		29.997 – 30.007 (1.1810 – 1.1813)
Diameter [mm (in.)]		29.994 – 30.000 (1.1809 – 1.1811)
Clearance in Connecting Rod Bushing [mm (in.)]		0.05 (0.002) max.
<b>Drive Belt Deflection</b>		
Fan (Generator) Belt [mm (in.)] / 98 N (10 kg, 22 lbf)	New	8.0 – 10.0 (0.32 – 0.39)
	Used	15.0 – 16.0 (0.59 – 0.63)
	Limit	17.0 (0.67)
A/C Belt [mm (in.)] / 98 N (10 kg, 22 lbf)	Used	8.0 – 10.0 (0.32 – 0.39)
P/S Belt [mm (in.)] / 98 N (10 kg, 22 lbf)	Used	6.0 – 7.0 (0.24 – 0.28)

## LUBURICATION SYSTEM

ITEM		SPECIFICATION
Capacity [ℓ (US qt, Imp qt)]	Oil pan	5.0 (5.3, 4.4)
	Total (dry engine)	6.1 (6.4, 5.4)
Engine Oil Type API service	CD, CE, or CF-4	SAE 5W-30, 5W-40 or 10W-30
<b>Oil Pump</b>		
Oil Pressure [kPa (kg/cm <sup>2</sup> , psi)]	3,000 rpm	500 (5.1, 72.5) min.
Inner Rotor Tooth Tip to Outer Rotor Clearance [mm (in.)]	Standard	0.2 (0.008) or less
	Maximum	0.24 (0.009)
Outer Rotor to Pump Body Clearance [mm (in.)]	Standard	0.09 – 0.184 (0.0036 – 0.0072)
	Maximum	0.22 (0.009)
Side Clearance [mm (in.)]	Standard	0.03 – 0.09 (0.0012 – 0.0035)
	Maximum	0.10 (0.004)
<b>Oil Filter</b>		
Type		Combined, paper element
Relief Pressure Differential [kPa (kg/cm <sup>2</sup> , psi)]		79 – 117 (0.8 – 1.2, 11 – 17)
<b>Oil Cooler</b>		
Type		Water cooled, 10 layer

## COOLING SYSTEM

ITEM		SPECIFICATION
Cooling Method		Water-cooled, forced circulation
Coolant Capacity [ℓ (US qt, Imp qt)]		6.6 (13.9, 11.6)
<b>Thermostat</b>		
Type		Wax, two stage
Start to Open [°C (°F)]		Main valve: 86.5 – 89.5 (187 – 191) Sub valve: 78.5 – 81.5 (174 – 178)
Full Open Lift [mm (in.)/°C (°F)]		Main valve: 8.0 (0.31) min./100 (212) Sub valve: 1.5 (0.06) min./100 (212)
<b>Radiator</b>		
Type		Corrugated fin
Cap Opening Valve Pressure [kPa (kg/cm <sup>2</sup> , psi)]		93 – 123 (0.94 – 1.25, 13.4 – 17.7)

## ENGINE ELECTRICAL SYSTEM

ITEM		SPECIFICATION
Battery	Voltage [V]	12
	Capacity [5 hour rate]	72
Starter	Brush length limit [mm (in.)]	11 (0.43)
Generator	Brush length limit [mm (in.)]	8 (0.32)
	Rotor coil resistance [ $\Omega$ ]	2.5–3.1
	Set voltage [V]	14.1 – 14.7 (at 20°C)

## HEATER AND AIR CONDITIONING SYSTEM

ITEM	SPECIFICATION
A/C Compressor Belt Deflection [mm (in.)]	8.0 – 10.0 (0.32 – 0.39)
Idle Up Speed (with A/C ON) [rpm]	800 $\pm$ 50

**SECTION 8A**

**WIRING DIAGRAM**

**SCHALTSCHHEMA**

**SCHEMA DE CABLAGE**

**DIAGRAMA DEL CABLEADO**

**CONTENTS**

**INHALT**

**TABLE DES MATIÈRES**

**ÍNDICE**

<b>INSTALLATION POSITIONS OF SINGLE UNIT PARTS</b> <b>EINBAUPOSITIONEN VON EINZELEINHEIT-TEILEN</b> <b>POSITIONS D'INSTALLATION DES PIÈCES INDIVIDUELLES</b> <b>POSICIONES DE INSTALACIÓN DE PARTES DE UNIDAD SENCILLA .....</b>	<b>8A-4</b>
<b>GROUND POINT</b> <b>MASSEPUNKT</b> <b>POINTS DE MASSE</b> <b>POINTS DE MASA .....</b>	<b>8A-5</b>
<b>POWER SUPPLY DIAGRAM</b> <b>STROMVERSORGUNGSDIAGRAMM</b> <b>SCHÉMA DU CIRCUIT D'ALIMENTATION</b> <b>DIAGRAMA DE ALIMENTACIÓN ELÉCTRICA .....</b>	<b>8A-6</b>
<b>SYSTEM CIRCUIT DIAGRAM</b> <b>SYSTEM-SCHALTDIAGRAMM</b> <b>SCHÉMA DES CIRCUITS ÉLECTRIQUES</b> <b>DIAGRAMA DEL CIRCUITO ELÉCTRICO .....</b>	<b>8A-7</b>

**SECTION 8A-4**  
**ABSCHNITT 8A-4**  
**SECTION 8A-4**  
**SECCIÓN 8A-4**

**INSTALLATION POSITIONS OF SINGLE UNIT PARTS**  
**EINBAUPOSITIONEN VON EINZELEINHEIT-TEILEN**  
**POSITIONS D'INSTALLATION DES PIÈCES**  
**INDIVIDUELLES**  
**POSICIONES DE INSTALACIÓN DE PARTES DE**  
**UNIDAD SENCILLA**

8A-4

**CONTENTS**  
**INHALT**  
**TABLE DES MATIÈRES**  
**ÍNDICE**

<b>ENGINE ROOM (RIGHT HAND STEERING VEHICLE) .....</b>	<b>8A-4-2</b>
<b>ENGINE ROOM (LEFT HAND STEERING VEHICLE) .....</b>	<b>8A-4-4</b>
<b>INSTRUMENT PANEL (RIGHT HAND STEERING VEHICLE) .....</b>	<b>8A-4-6</b>
<b>INSTRUMENT PANEL (LEFT HAND STEERING VEHICLE) .....</b>	<b>8A-4-7</b>
<b>MOTORRAUM (FAHRZEUG MIT RECHTSLENKUNG) .....</b>	<b>8A-4-2</b>
<b>MOTORRAUM (FAHRZEUG MIT LINKSLENKUNG) .....</b>	<b>8A-4-4</b>
<b>ARMATURENBRETT (FAHRZEUG MIT RECHTSLENKUNG) .....</b>	<b>8A-4-6</b>
<b>ARMATURENBRETT (FAHRZEUG MIT LINKSLENKUNG) .....</b>	<b>8A-4-7</b>
<b>COMPARTIMENT MOTEUR (VEHICULE A CONDUITE A DROITE) .....</b>	<b>8A-4-2</b>
<b>COMPARTIMENT MOTEUR (VEHICULE A CONDUITE A GAUCHE) .....</b>	<b>8A-4-4</b>
<b>PANNEAU D'INSTRUMENTS (VEHICULE A CONDUITE A DROITE) .....</b>	<b>8A-4-6</b>
<b>PANNEAU D'INSTRUMENTS (VEHICULE A CONDUITE A GAUCHE) .....</b>	<b>8A-4-7</b>
<b>COMPARTIMIENTO DEL MOTOR (VEHÍCULO CON DIRECCIÓN A LA DERECHA) .....</b>	<b>8A-4-2</b>
<b>COMPARTIMIENTO DEL MOTOR (VEHÍCULO CON DIRECCIÓN A LA IZQUIERDA) .....</b>	<b>8A-4-4</b>
<b>TABLERO DE INSTRUMENTOS (VEHÍCULO CON DIRECCIÓN A LA DERECHA) .....</b>	<b>8A-4-6</b>
<b>TABLERO DE INSTRUMENTOS (VEHÍCULO CON DIRECCIÓN A LA IZQUIERDA) .....</b>	<b>8A-4-7</b>

**ENGINE ROOM (RIGHT HAND STEERING VEHICLE)**

**MOTORRAUM (FAHRZEUG MIT RECHTSLENKUNG)**

**COMPARTIMENT MOTEUR (VEHICULE A CONDUITE A DROITE)**

**COMPARTIMIENTO DEL MOTOR (VEHÍCULO CON DIRECCIÓN A LA DERECHA)**

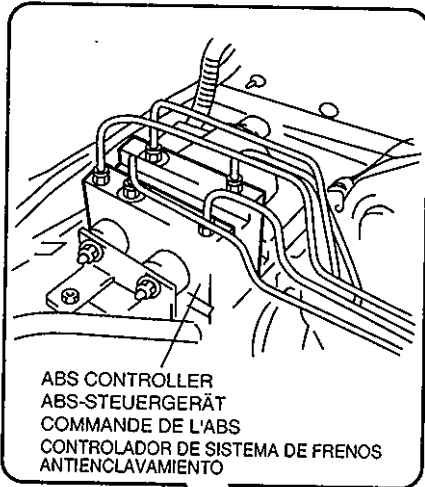

FUSIBLE LINK  
SCHMELZSICHERUNG  
LAME FUSIBLE  
ESLABON FUSIBLE

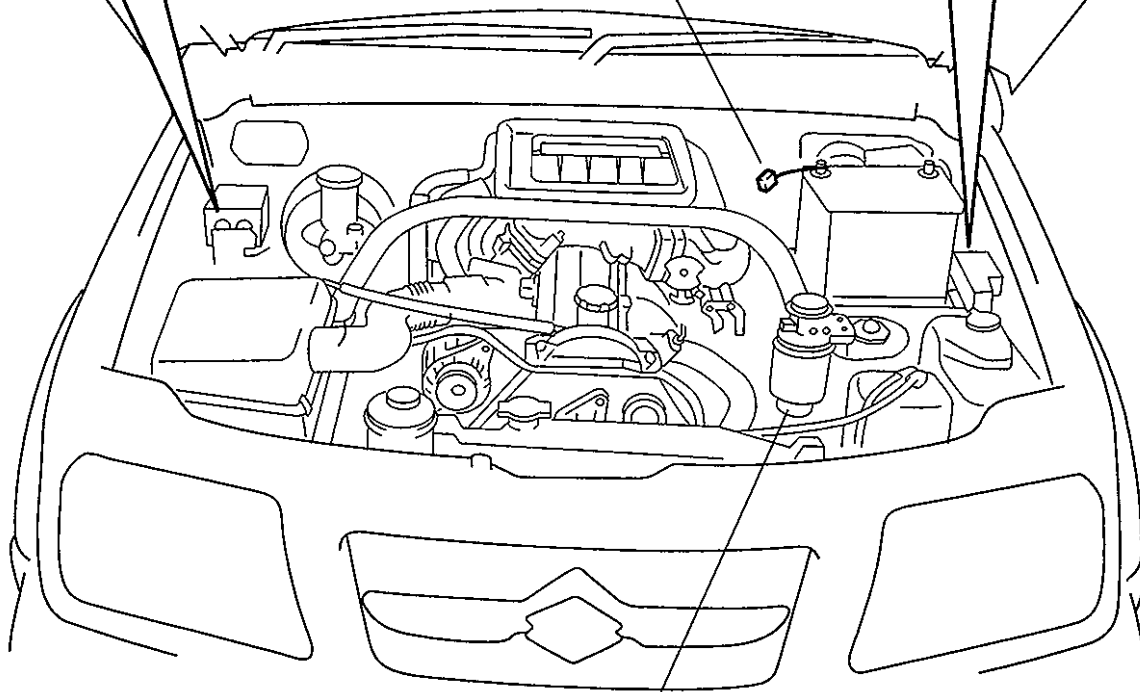
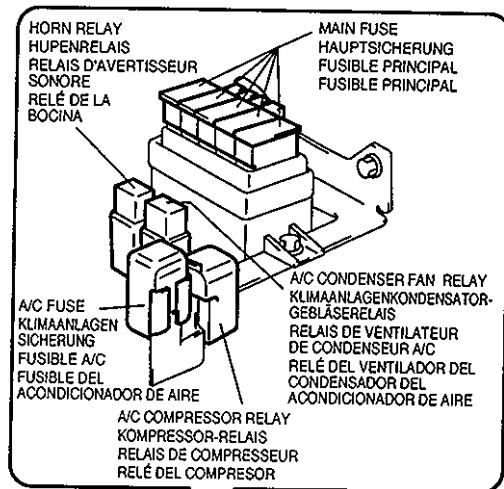

SEDIMENT SWITCH  
SEDIMENTSCHALTER  
CONTACTEUR DE  
SEDIMENT  
INTERRUPTOR DE  
SEDIMENTOS

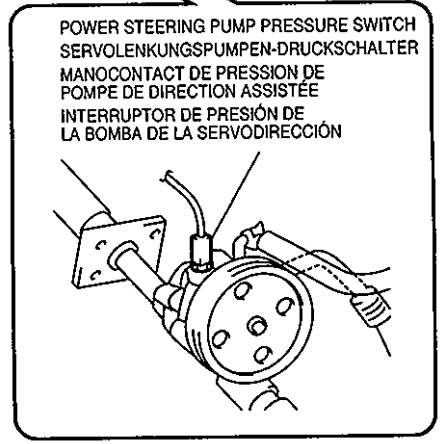
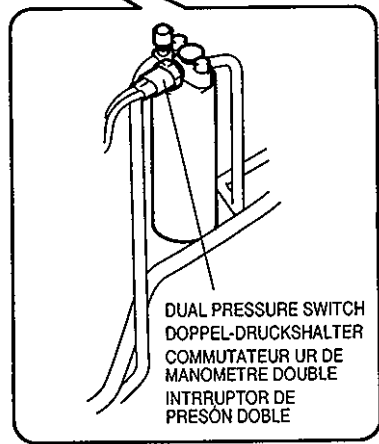
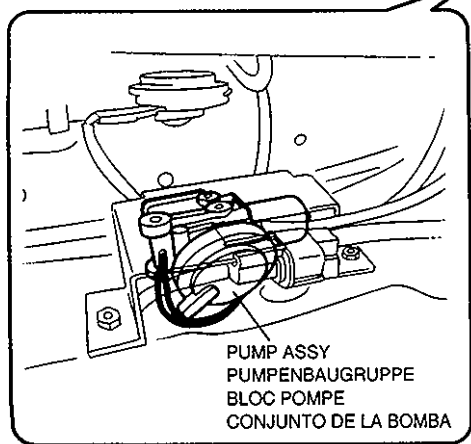
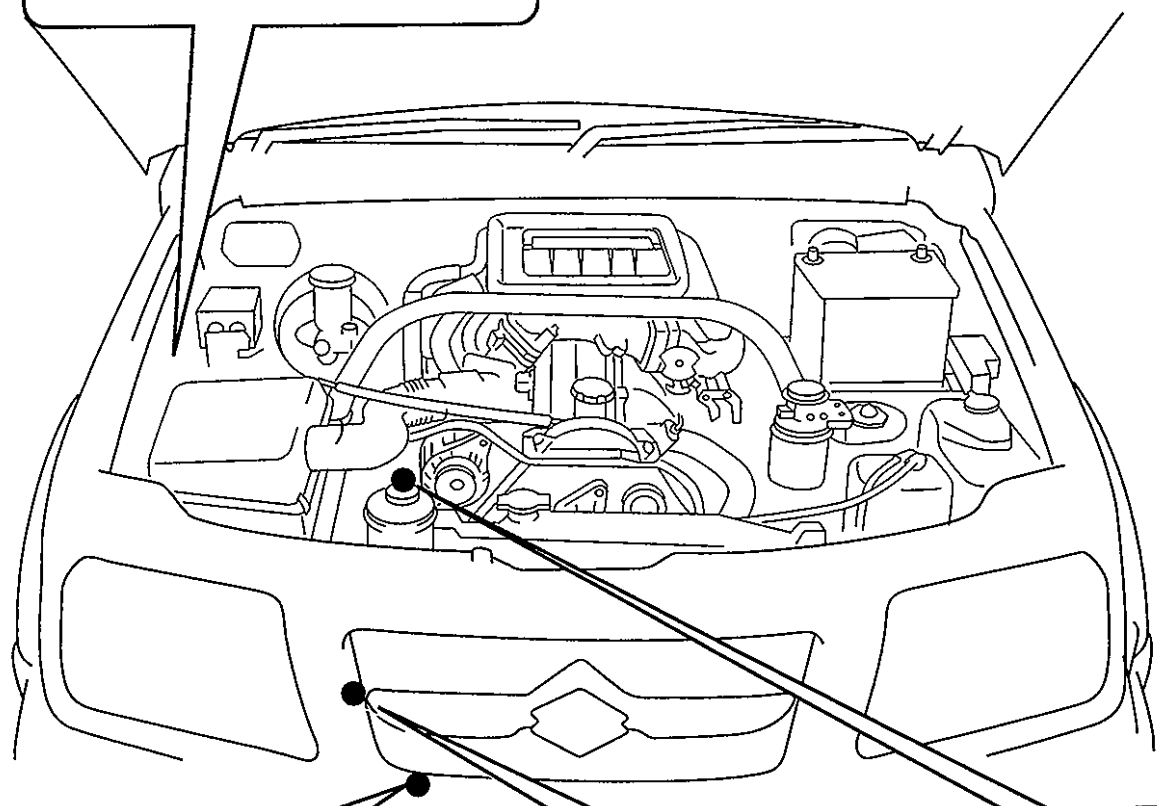
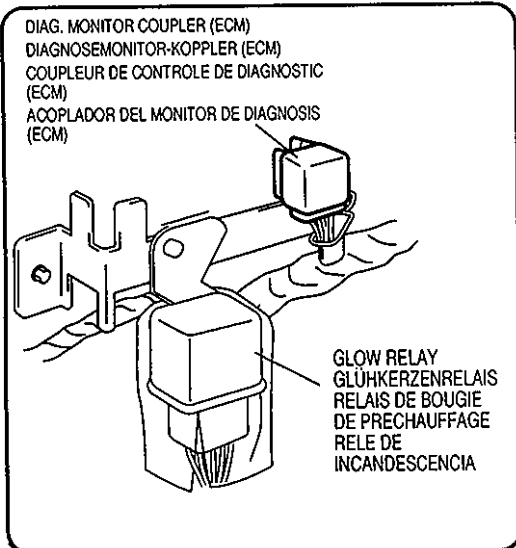

**ENGINE ROOM (LEFT HAND STEERING VEHICLE)**

**MOTORRAUM (FAHRZEUG MIT LINKSLENKUNG)**

**COMPARTIMENT MOTEUR (VEHICULE A CONDUITE A GAUCHE)**

**COMPARTIMIENTO DEL MOTOR (VEHÍCULO CON DIRECCIÓN A LA IZQUIERDA)**

FUSIBLE LINK  
SCHMELZSICHERUNG  
LAME FUSIBLE  
ESLABON FUSIBLE

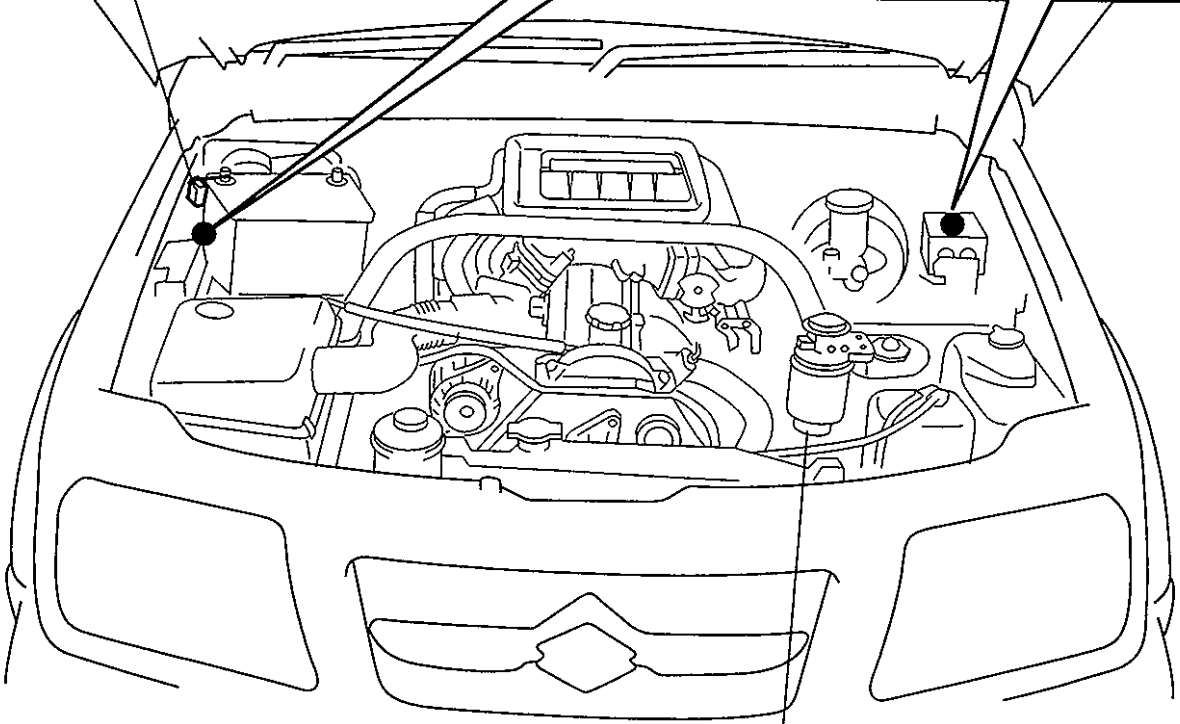
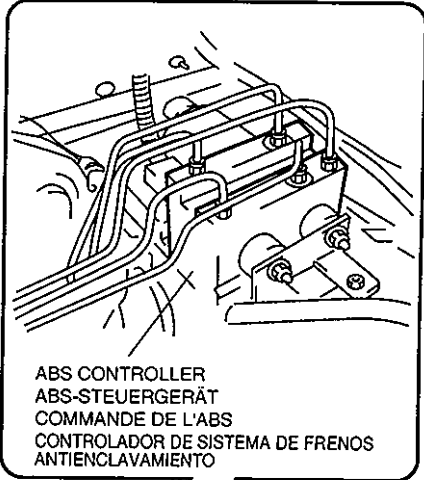
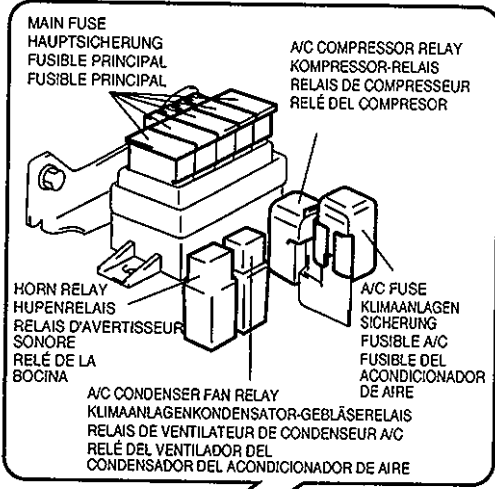

SEDIMENT SWITCH  
SEDIMENTSCHALTER  
CONTACTEUR DE  
SEDIMENT  
INTERRUPTOR DE  
SEDIMENTOS

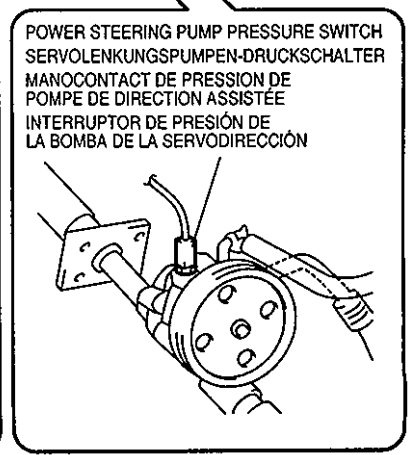
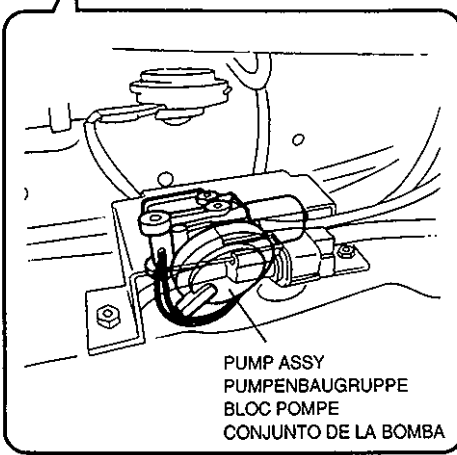
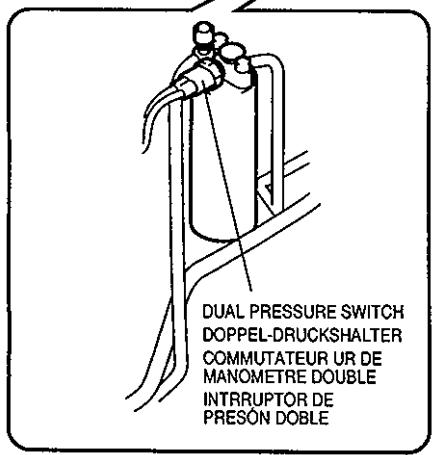
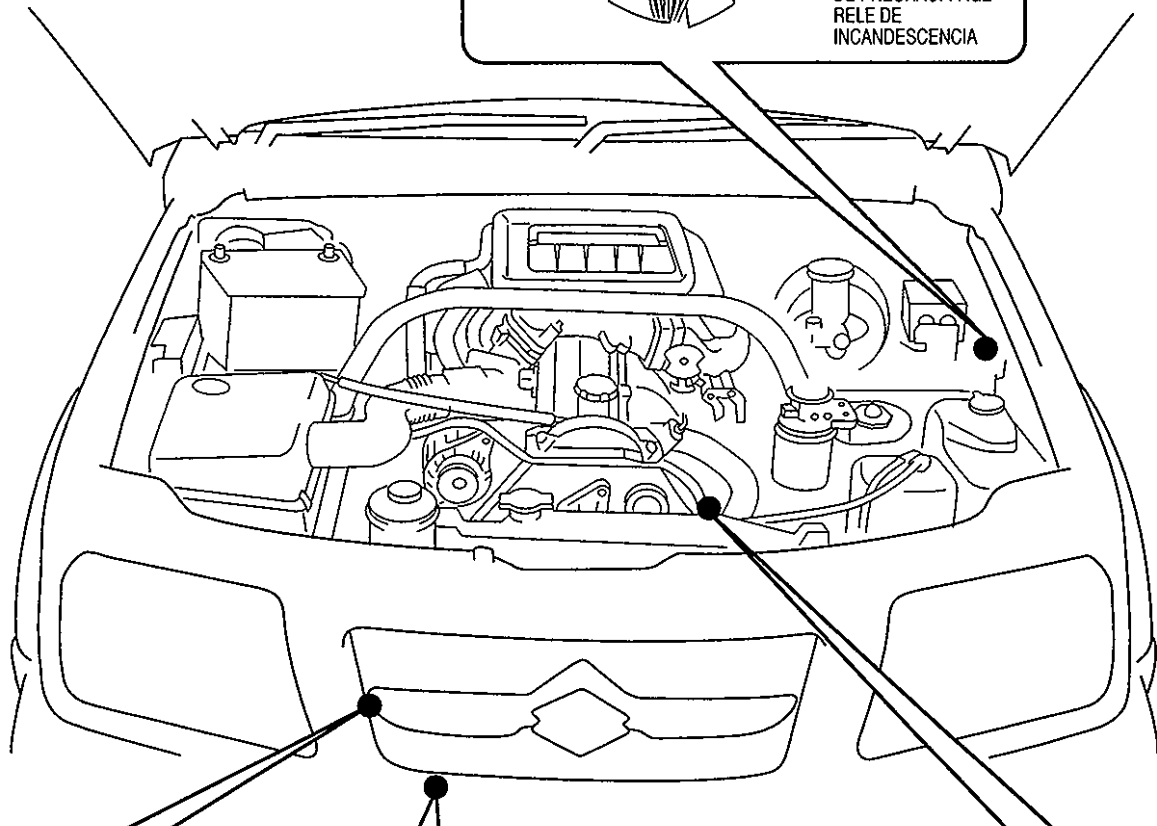
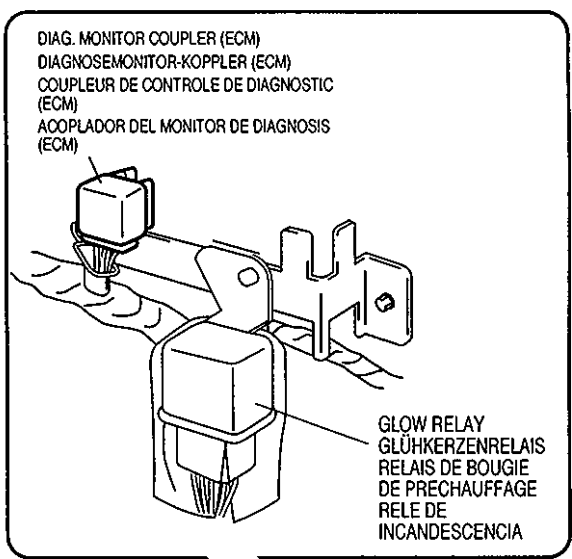

**INSTRUMENT PANEL (RIGHT HAND STEERING VEHICLE)**

**ARMATURENBRETT (FAHRZEUG MIT RECHTSLENKUNG)**

**PANNEAU D'INSTRUMENTS (VEHICULE A CONDUITE A DROITE)**

**TABLERO DE INSTRUMENTOS (VEHÍCULO CON DIRECCIÓN A LA DERECHA)**

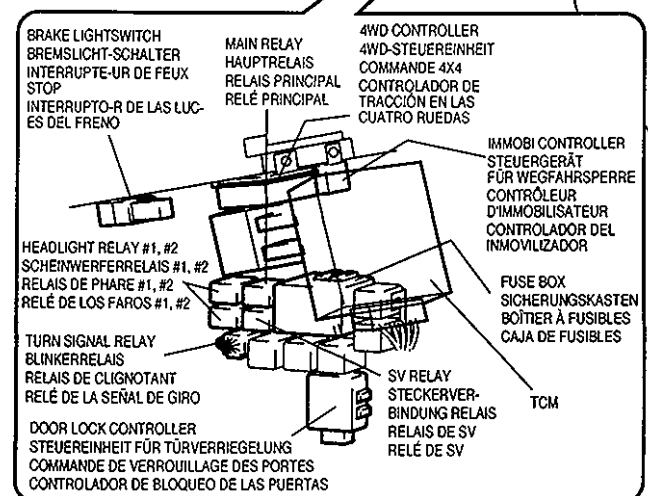
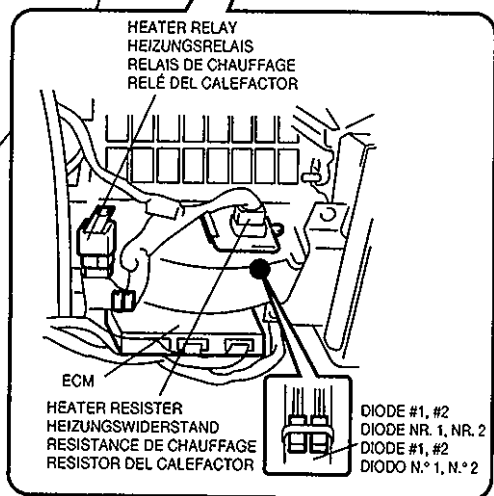
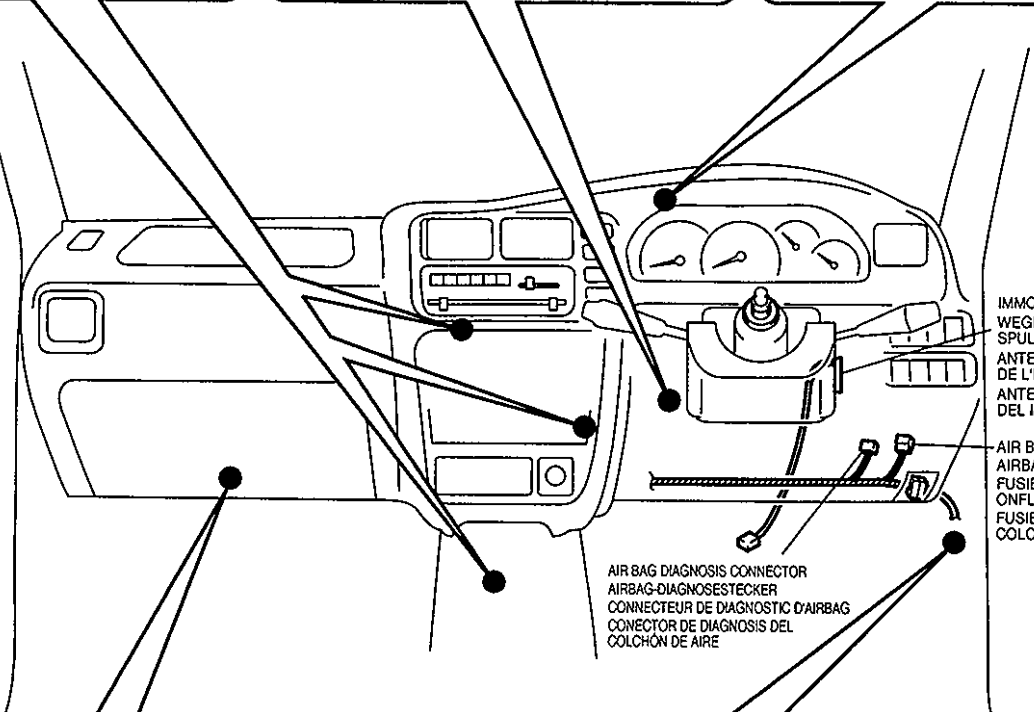
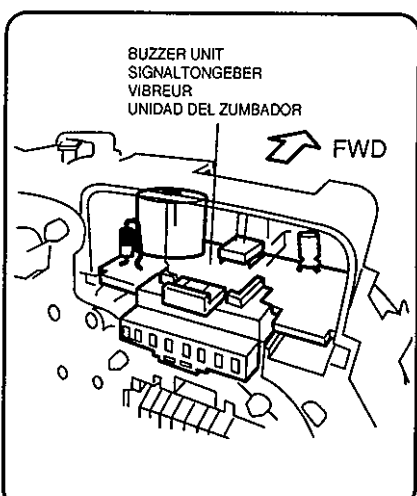
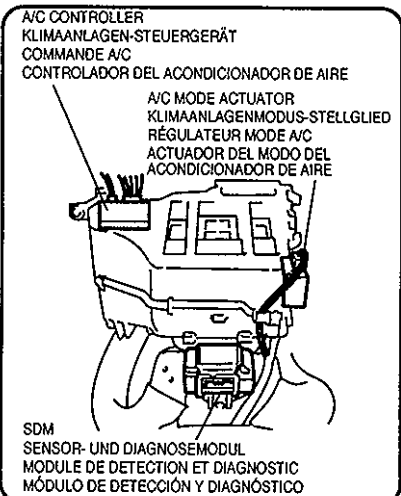

**INSTRUMENT PANEL (LEFT HAND STEERING VEHICLE)**  
**ARMATURENBRETT (FAHRZEUG MIT LINKSLENKUNG)**  
**PANNEAU D'INSTRUMENTS (VEHICULE A CONDUITE A GAUCHE)**  
**TABLERO DE INSTRUMENTOS (VEHÍCULO CON DIRECCIÓN A LA IZQUIERDA)**

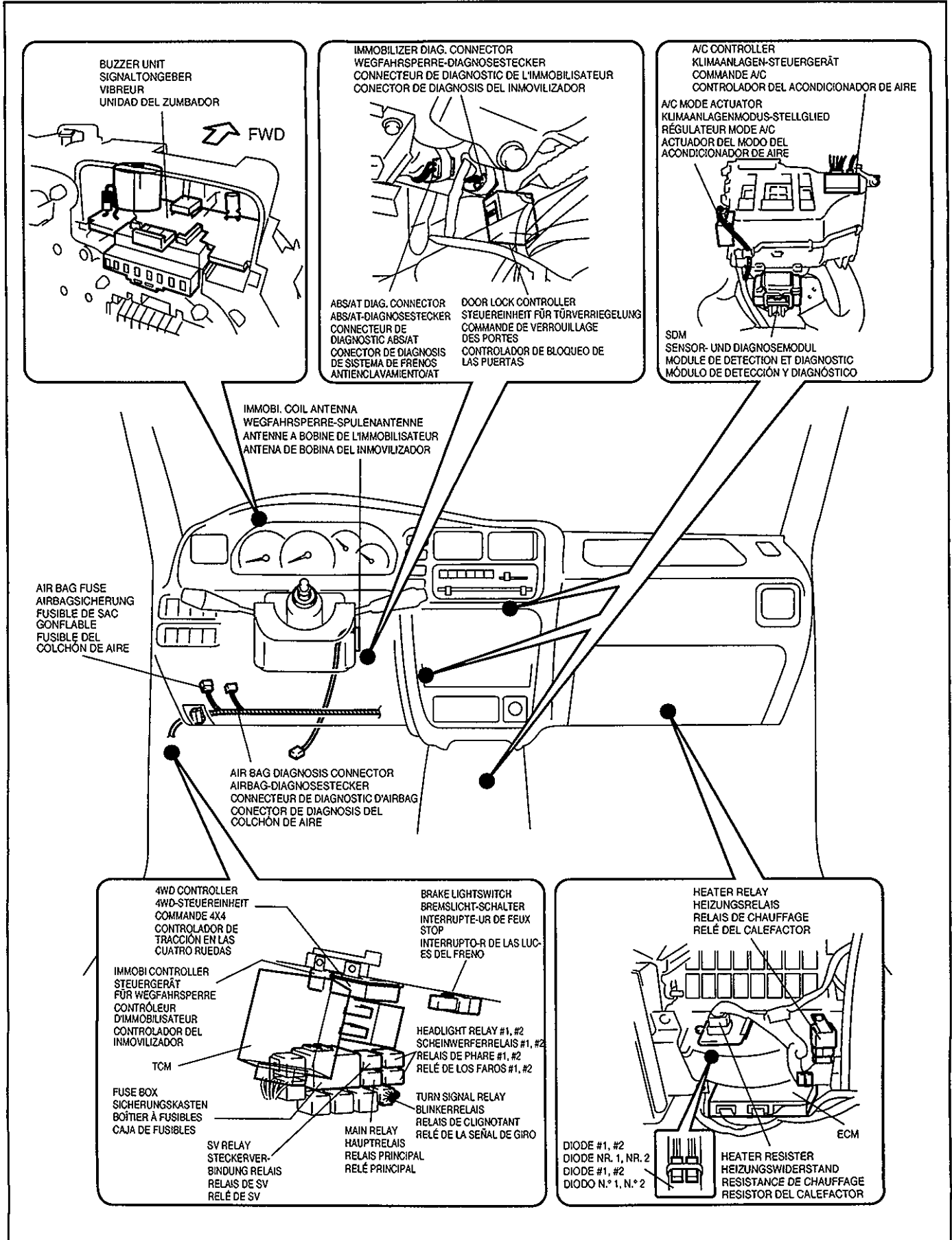

**SECTION 8A-5**  
**ABSCHNITT 8A-5**  
**SECTION 8A-5**  
**SECCIÓN 8A-5**

**GROUND POINT**  
**MASSEPUNKT**  
**POINTS DE MASSE**  
**POINTS DE MASA**

8A-5

**CONTENTS**  
**INHALT**  
**TABLE DES MATIÈRES**  
**ÍNDICE**

- ENGINE ROOM (RIGHT HAND STEERING VEHICLE).....8A-5-2
- ENGINE ROOM (LEFT HAND STEERING VEHICLE) .....8A-5-3
  
- MOTORRAUM (FAHRZEUG MIT RECHTSLENKUNG).....8A-5-2
- MOTORRAUM (FAHRZEUG MIT LINKSLENKUNG) .....8A-5-3
  
- COMPARTIMENT MOTEUR (VEHICULE A CONDUITE A DROITE).....8A-5-2
- COMPARTIMENT MOTEUR (VEHICULE A CONDUITE A GAUCHE) .....8A-5-3
  
- COMPARTIMIENTO DEL MOTOR (VEHÍCULO CON DIRECCIÓN A LA DERECHA) .....8A-5-2
- COMPARTIMIENTO DEL MOTOR (VEHÍCULO CON DIRECCIÓN A LA IZQUIERDA) .....8A-5-3

ENGINE ROOM (RIGHT HAND STEERING VEHICLE)

MOTORRAUM (FAHRZEUG MIT RECHTSLENKUNG)

COMPARTIMENT MOTEUR (VEHICULE A CONDUITE A DROITE)

COMPARTIMIENTO DEL MOTOR (VEHÍCULO CON DIRECCIÓN A LA DERECHA)

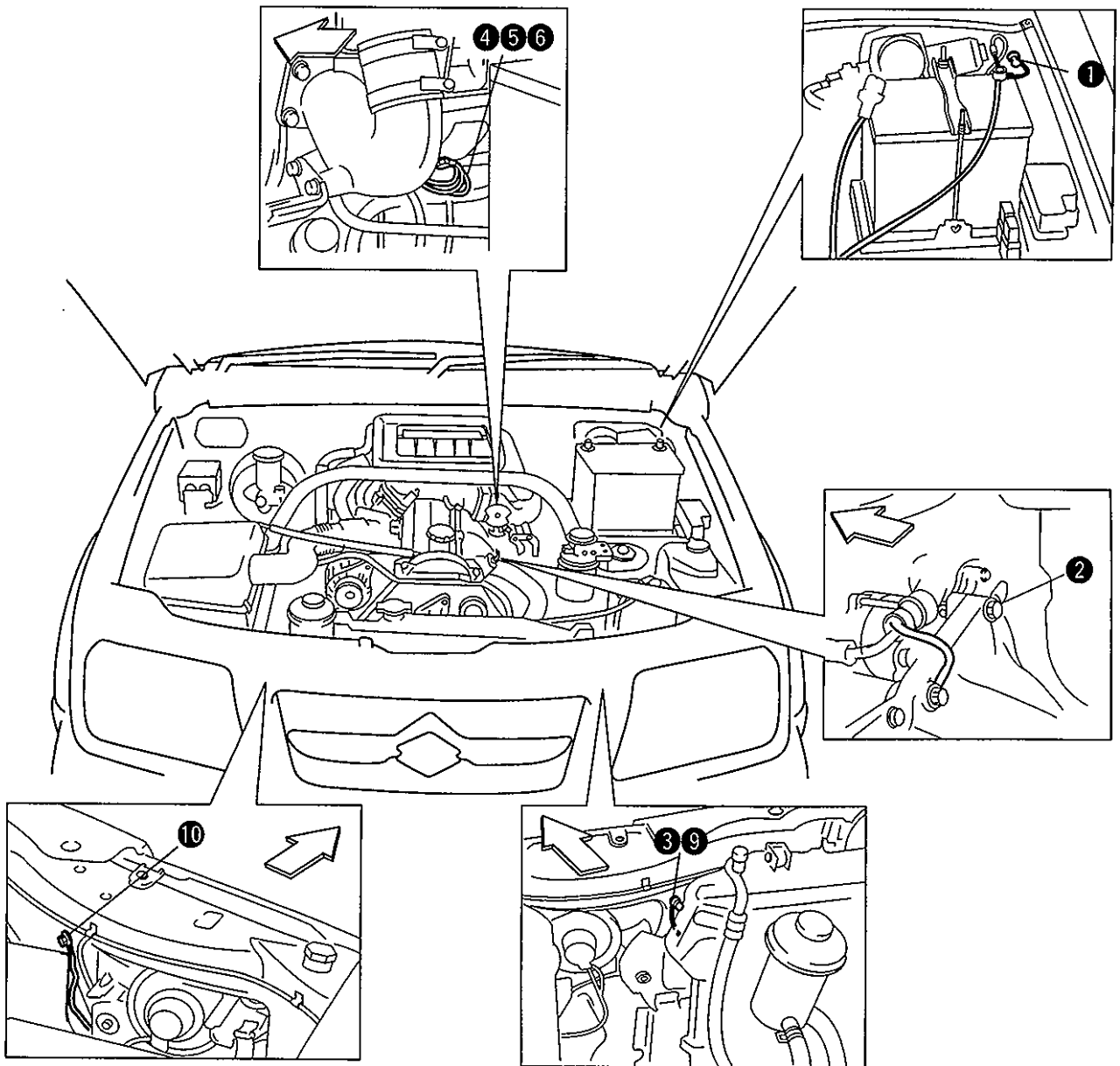

ENGINE ROOM (LEFT HAND STEERING VEHICLE)  
MOTORRAUM (FAHRZEUG MIT LINKSLENKUNG)  
COMPARTIMENT MOTEUR (VEHICULE A CONDUITE A GAUCHE)  
COMPARTIMIENTO DEL MOTOR (VEHÍCULO CON DIRECCIÓN A LA IZQUIERDA)

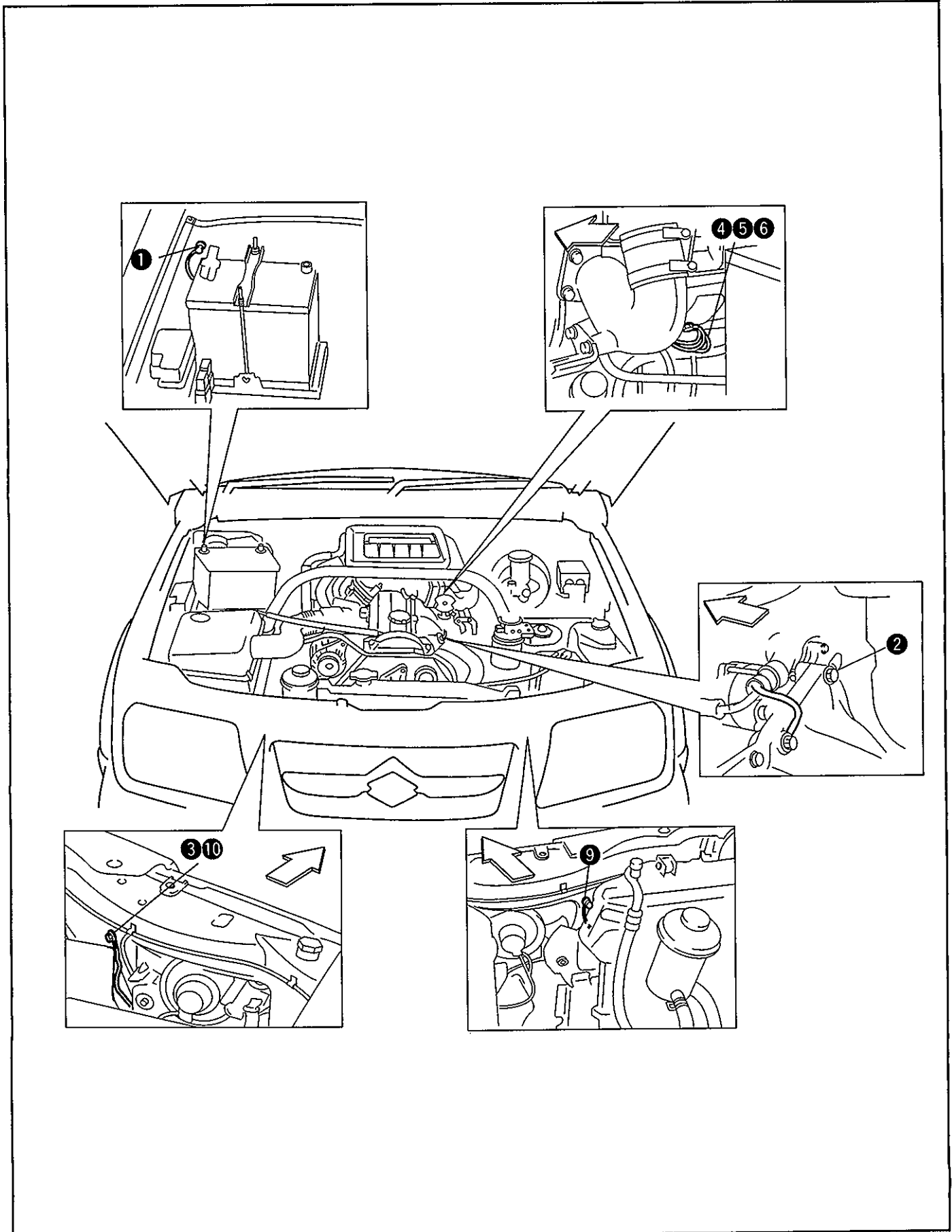

**SECTION 8A-6**  
**ABSCHNITT 8A-6**  
**SECTION 8A-6**  
**SECCIÓN 8A-6**

**POWER SUPPLY DIAGRAM**  
**STROMVERSORGUNGSDIAGRAMM**  
**SCHÉMA DU CIRCUIT D'ALIMENTATION**  
**DIAGRAMA DE ALIMENTACIÓN ELÉCTRICA**

**CONTENTS**  
**INHALT**  
**TABLE DES MATIÈRES**  
**ÍNDICE**

8A-6

• POWER SUPPLY DIAGRAM .....	8A-6-2
• MAIN FUSE .....	8A-6-3
• FUSE .....	8A-6-3
• STROMVERSORGUNGSDIAGRAMM .....	8A-6-2
• HAUPTSICHERUNG .....	8A-6-3
• SICHERUNG .....	8A-6-3
• SCHÉMA DU CIRCUIT D'ALIMENTATION .....	8A-6-2
• FUSIBLE PRINCIPAL .....	8A-6-3
• FUSIBLE .....	8A-6-3
• DIAGRAMA DE LA ALIMENTACIÓN ELÉCTRICA .....	8A-6-2
• FUSIBLE PRINCIPAL .....	8A-6-3
• FUSIBLE .....	8A-6-3

**POWER SUPPLY DIAGRAM**  
**STROMVERSORGUNGSDIAGRAMM**  
**SCHEMA DU CIRCUIT D'ALIMENTATION**  
**DIAGRAMA DE ALIMENTACIÓN ELÉCTRICA**

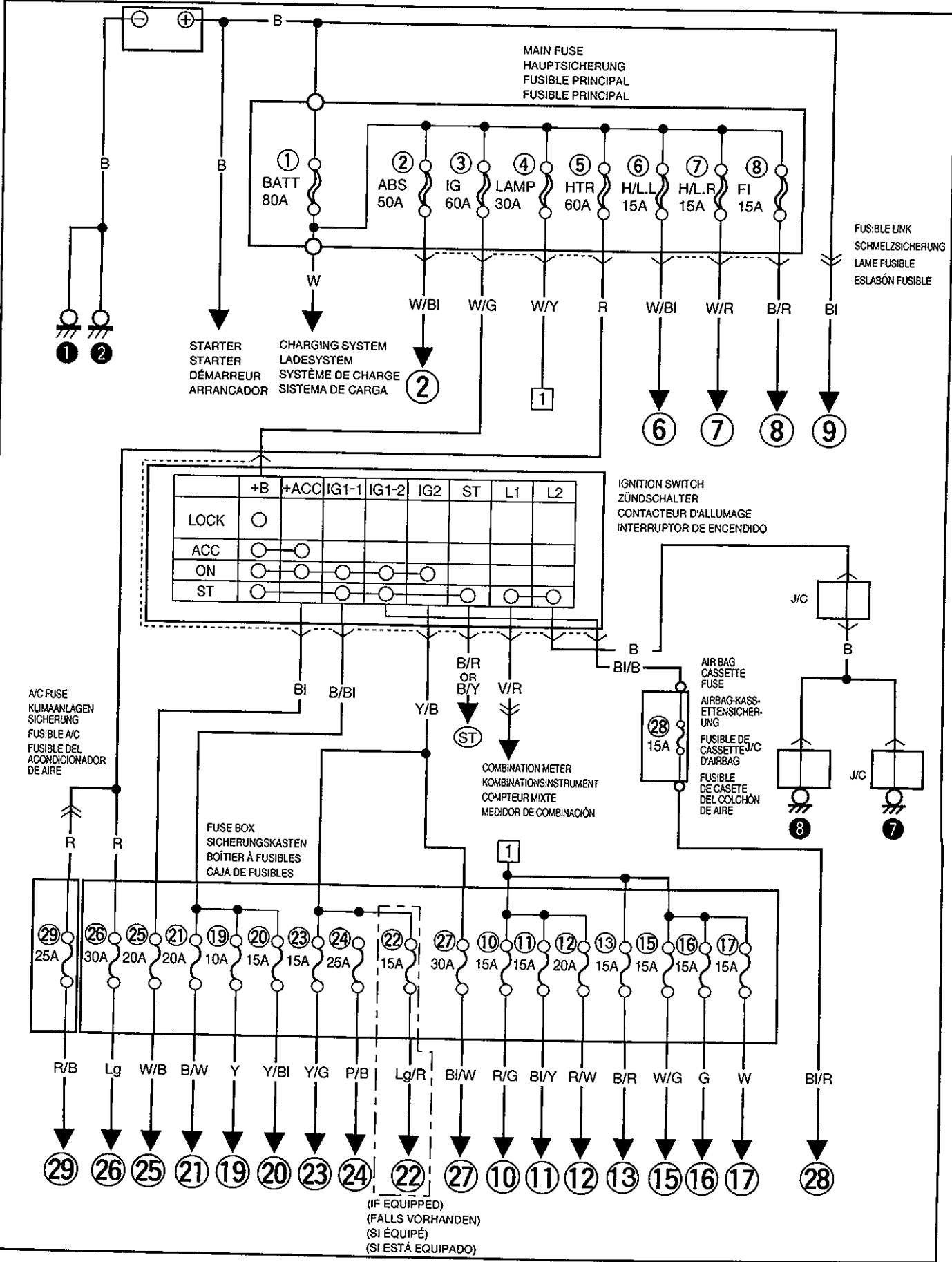

**MAIN FUSE  
 HAUPTSICHERUNG  
 FUSIBLE PRINCIPAL  
 FUSIBLE PRINCIPAL**

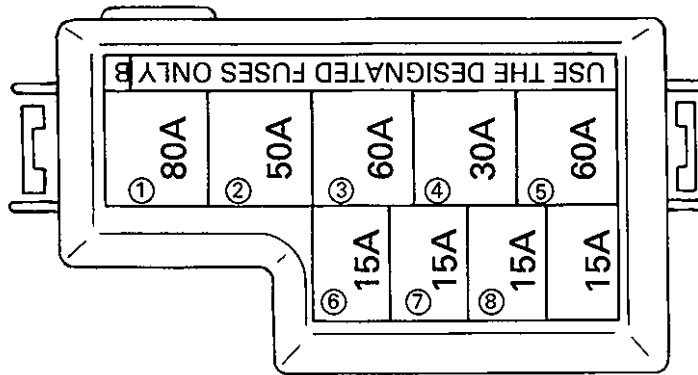

**FUSE  
 SICHERUNG  
 FUSIBLE  
 FUSIBLE**

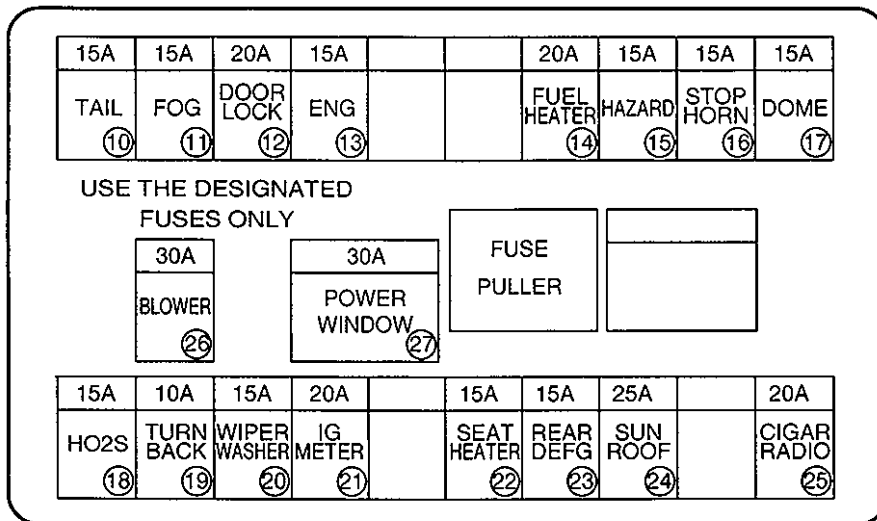

**NOTE :**  
 The number at each fuse corresponds to that of Power Supply Diagram (8A-6-6) or System Circuit Diagram (8A-7).

**HINWEIS:**  
 Die Nummer jeder Sicherung entspricht der jeweiligen Nummer auf dem Stromversorgungsdiagramm (8A-6-6) oder Systemschaltdiagramm (8A-7).

**REMARQUE:**  
 Le numéro de chaque fusible correspond à celui indiqué sur le schéma du circuit d'alimentation (8A-6-6) ou du schéma des circuits électriques (8A-7).

**NOTA:**  
 El número de cada fusible corresponde al del diagrama de alimentación eléctrica (8A-6-6) o diagrama del circuito del sistema (8A-7).

## SECTION 8A-7

## SYSTEM CIRCUIT DIAGRAM

## CONTENTS

CRANKING SYSTEM .....	8A-7-5
CHARGING SYSTEM .....	8A-7-6
IMMOBILIZER CONTROL SYSTEM .....	8A-7-7
IGNITION, ENGINE & EMISSION CONTROL SYSTEM .....	8A-7-8
4A/T CONTROL SYSTEM .....	8A-7-12
4WD CONTROL SYSTEM .....	8A-7-14
METER & GAUGE .....	8A-7-15
INDICATOR LAMP .....	8A-7-16
INDICATOR LAMP .....	8A-7-17
WARNING LAMP .....	8A-7-18
HEADLIGHT SYSTEM .....	8A-7-20
ILLUMINATION LAMP (RIGHT HAND STEERING VEHICLE) .....	8A-7-22
ILLUMINATION LAMP (LEFT HAND STEERING VEHICLE) .....	8A-7-24
BUCK-UP LIGHT .....	8A-7-26
HEATER AND AIR CONDITIONING .....	8A-7-28
ANTI-LOCK BRAKE SYSTEM .....	8A-7-32

**CRANKING SYSTEM**  
**KURBELSYSTEM**  
**SYSTÈME DE DÉMARRAGE**  
**SISTEMA DE ARRANQUE**

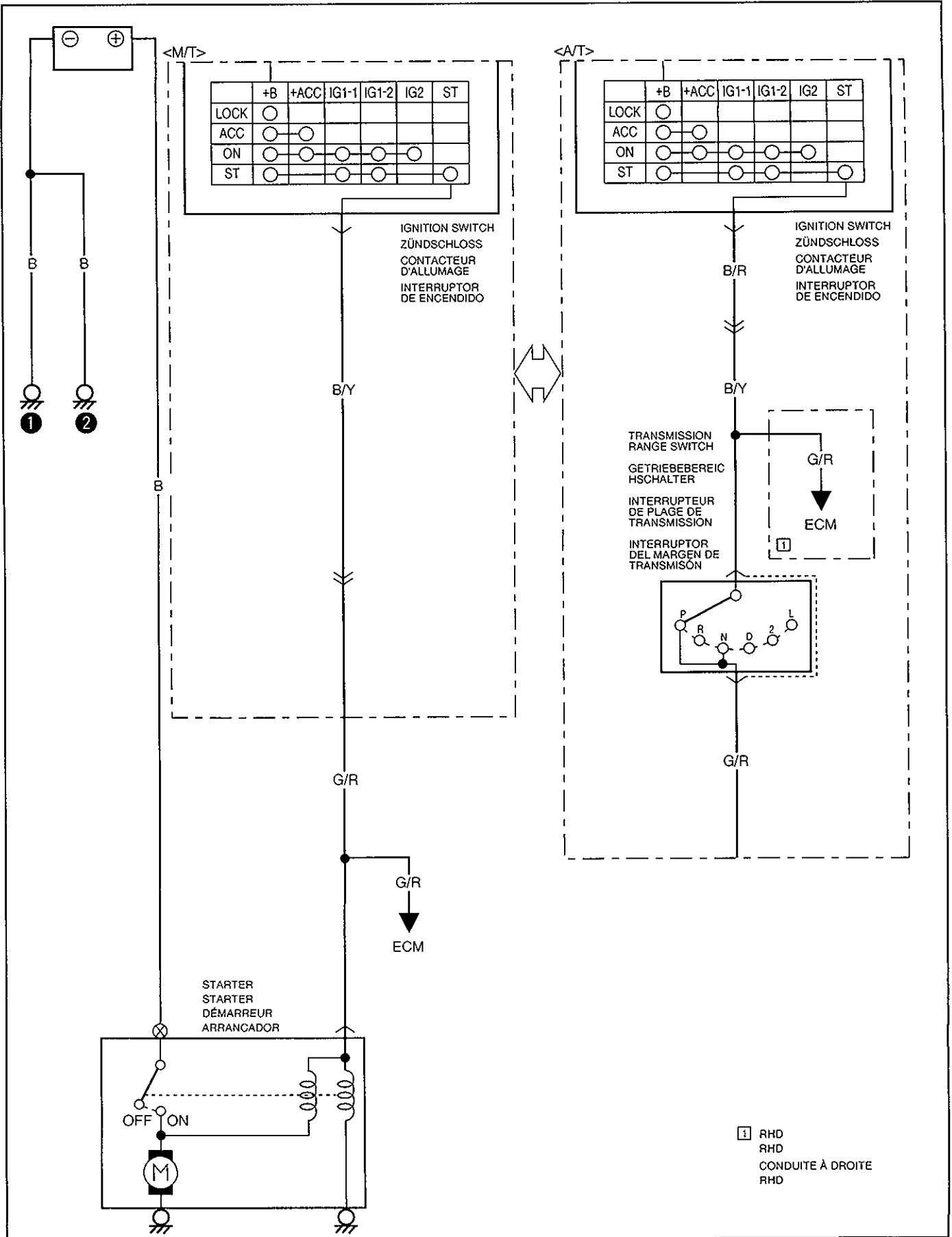

**CHARGING SYSTEM**  
**LADESYSTEM**  
**SYSTÈME DE CHARGE**  
**SISTEMA DE CARGA**

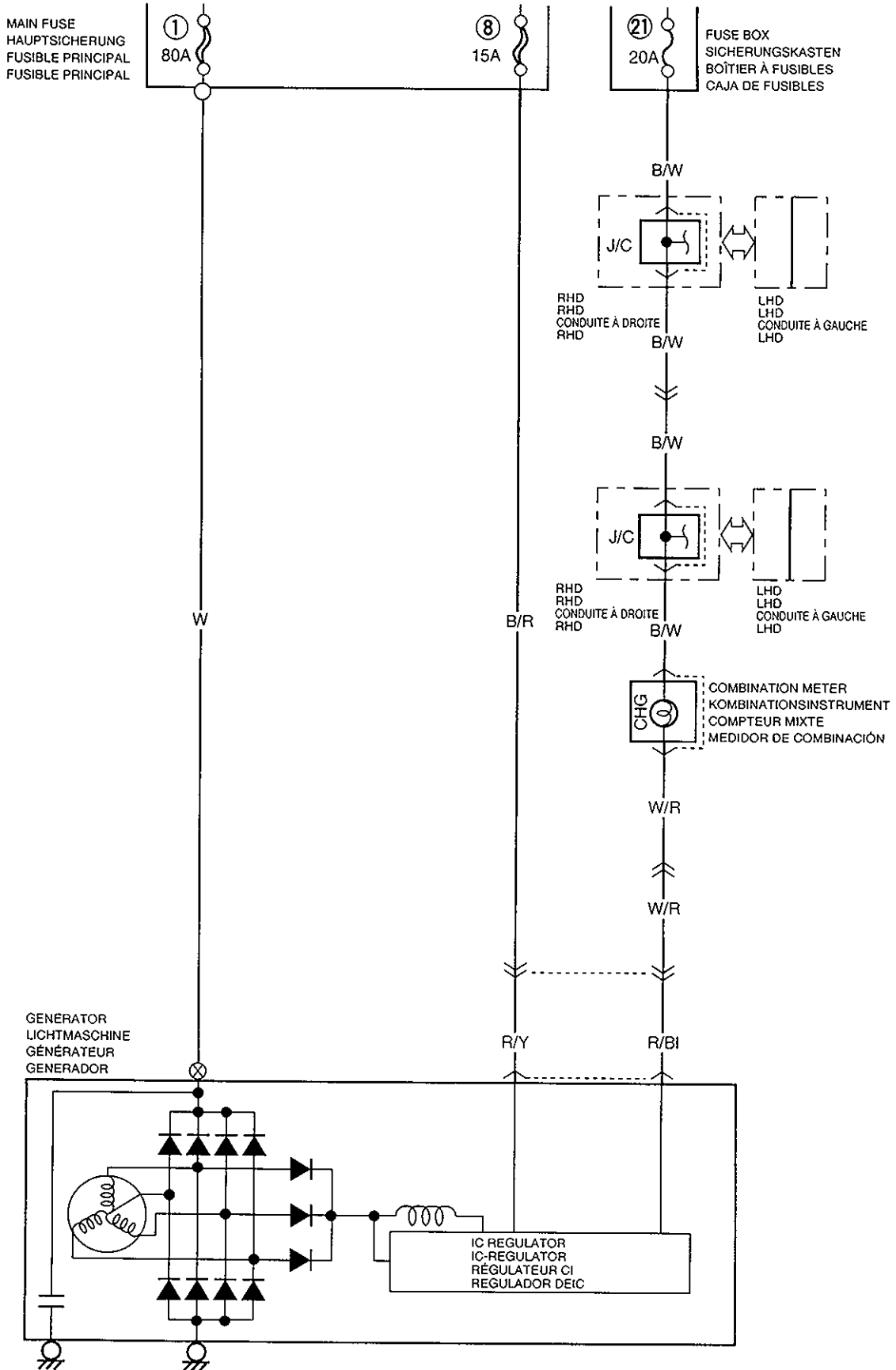

**IMMOBILIZER CONTROL SYSTEM**  
**WEGFAHRSPERRE-STEUERSYSTEM**  
**SYSTÈME DE COMMANDE DE L'IMMOBILISATEUR**  
**SISTEMA DE CONTROL DEL INMOVILIZADOR**

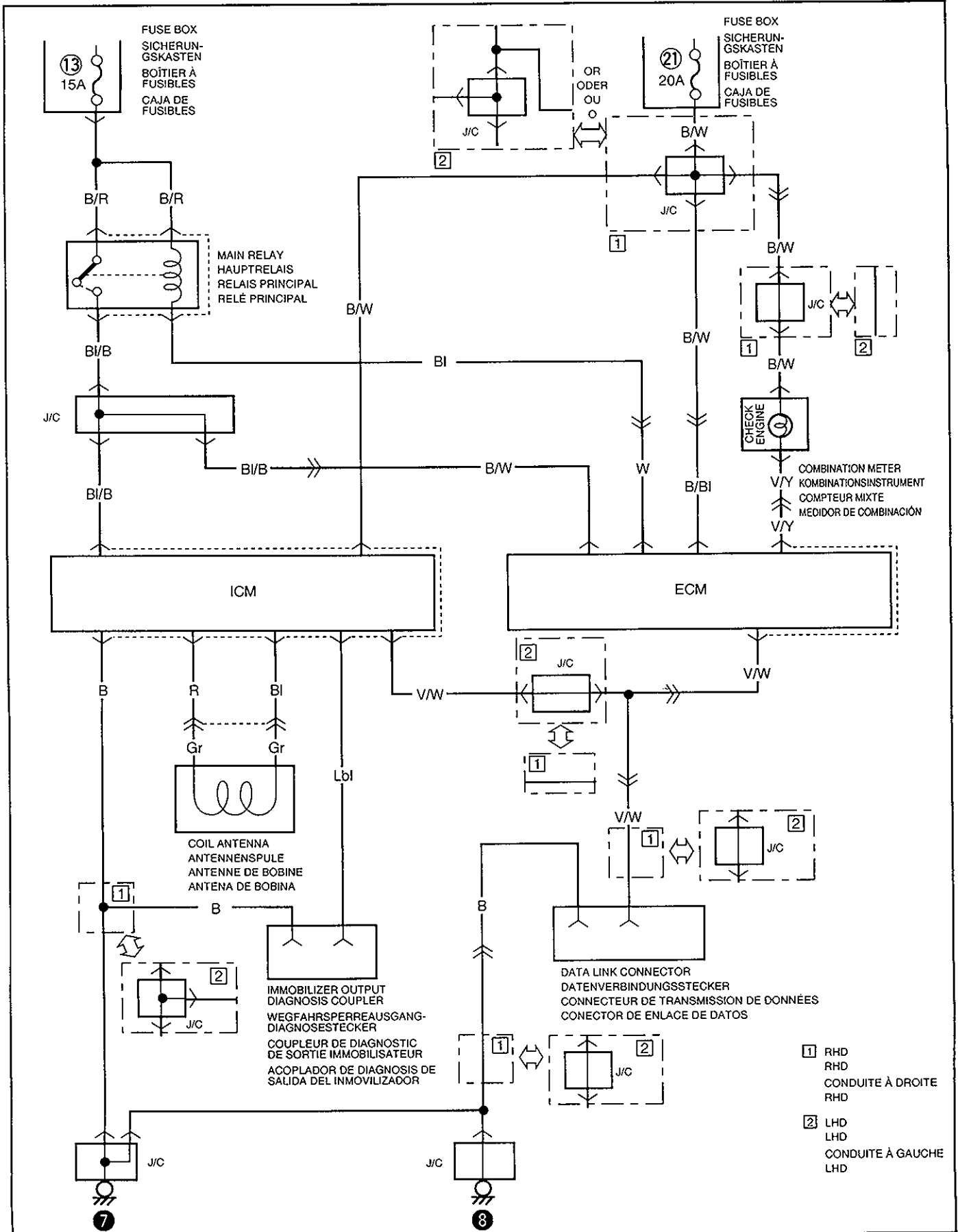



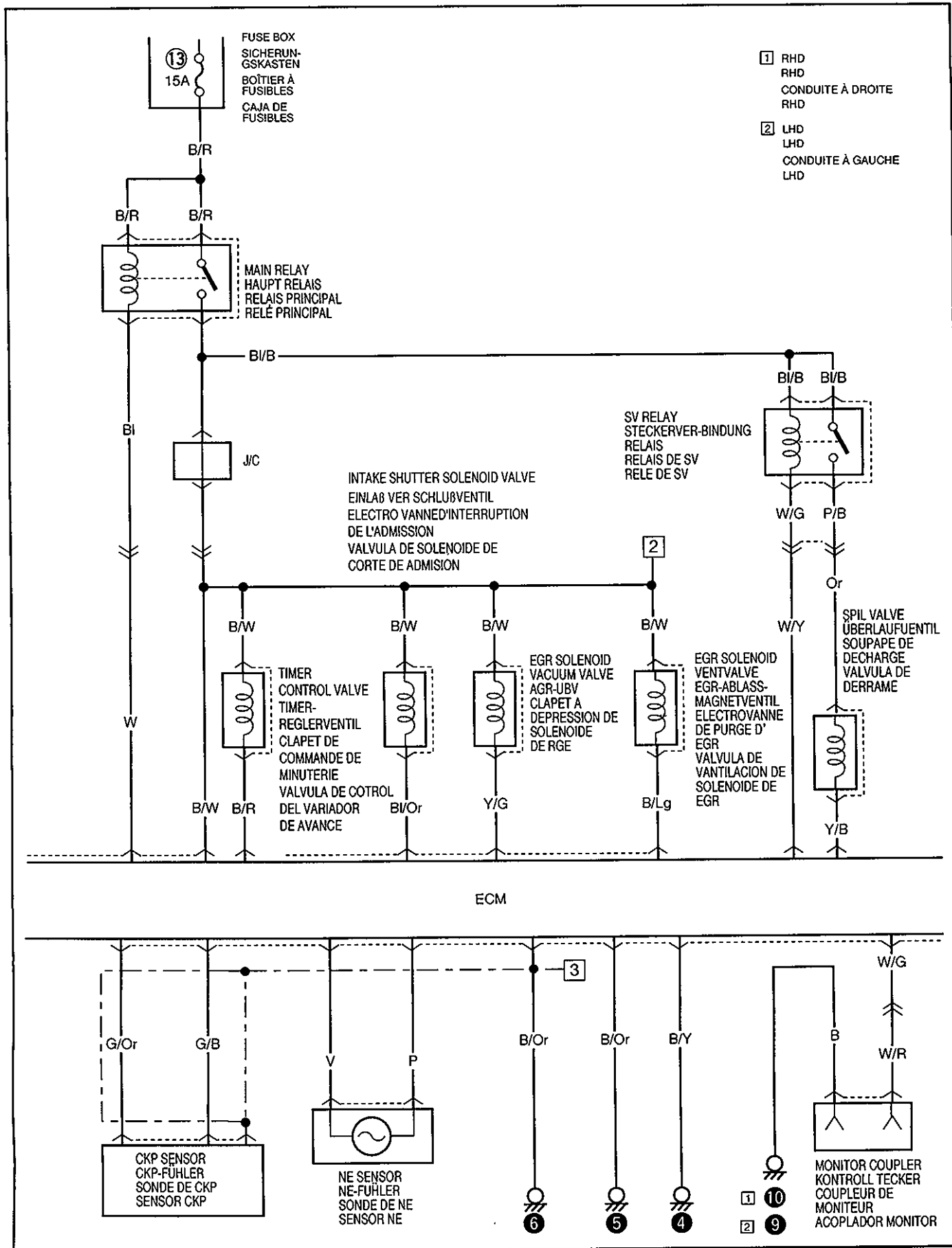

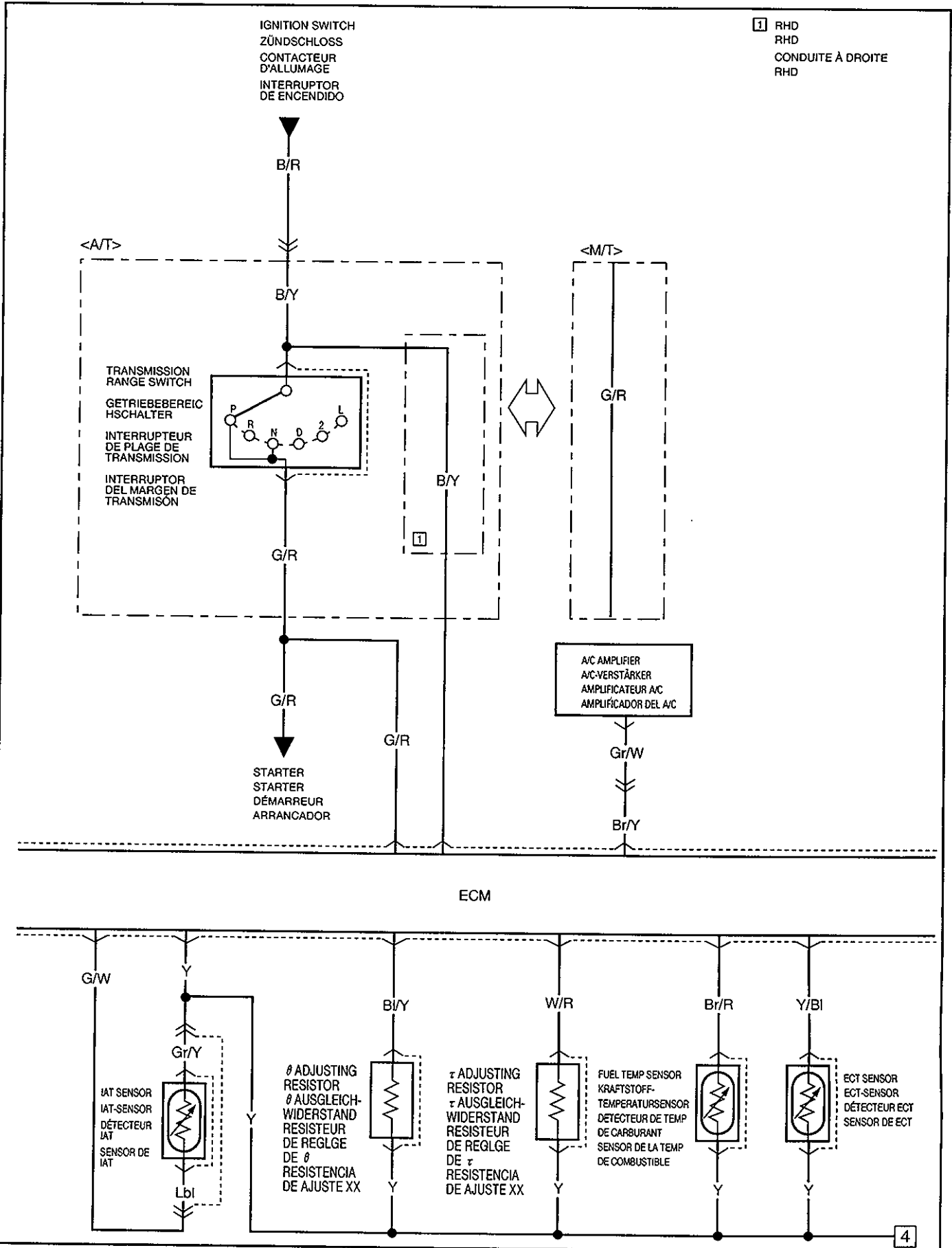

- 1 RHD  
RHD  
CONDUITE À DROITE  
RHD
- 2 LHD  
LHD  
CONDUITE À GAUCHE  
LHD

DATA LINK CONNECTOR  
 DATENVERBINDUNGSSTECKER  
 CONNECTEUR DE  
 TRANSMISSION DE DONNÉES  
 CONECTOR DE ENLACE DE  
 DATOS

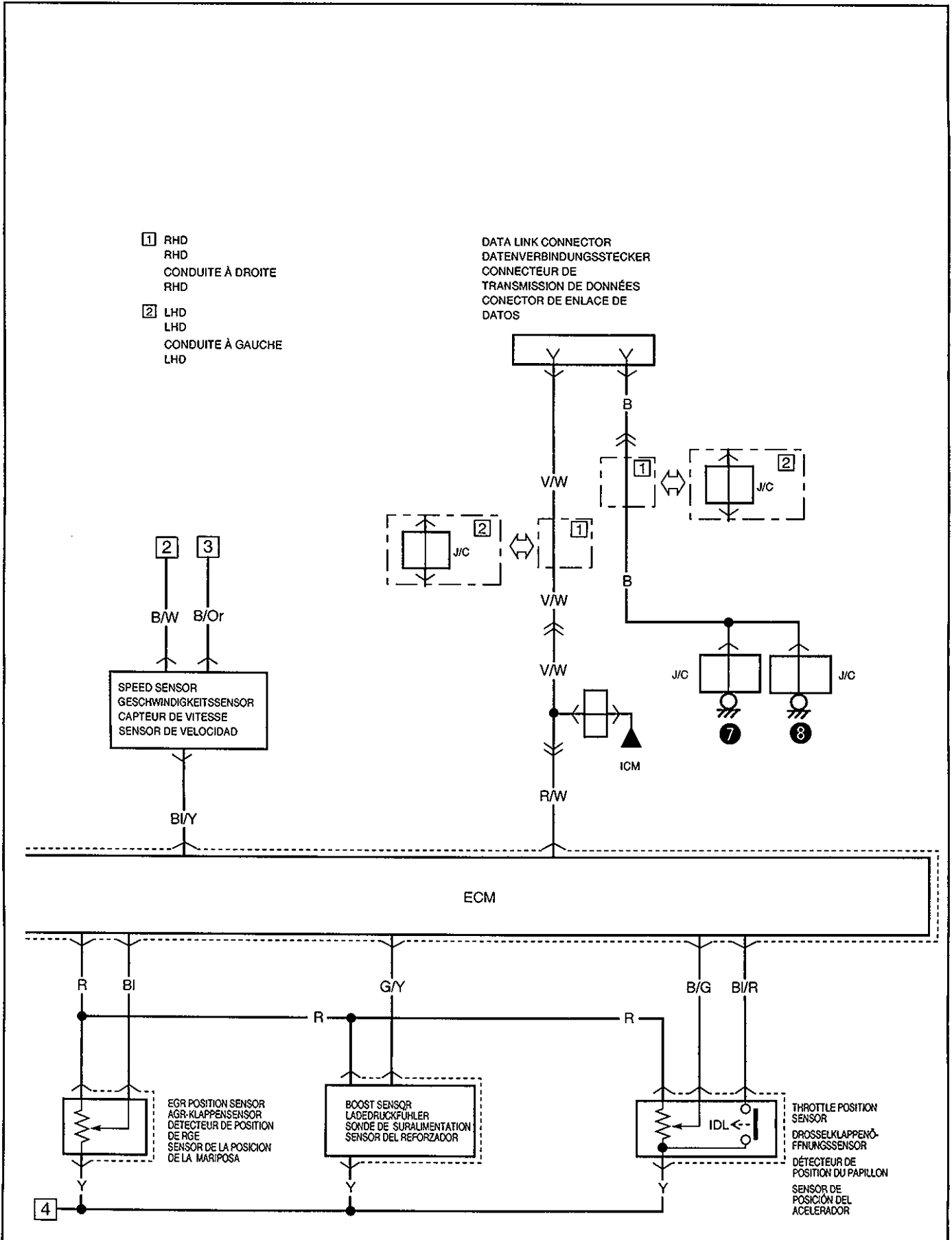

4A/T CONTROL SYSTEM

4A/T STEUERSYSTEM

SYSTEME DE COMMANDE 4A/T

SISTEMA DE CONTROL DE 4A/T

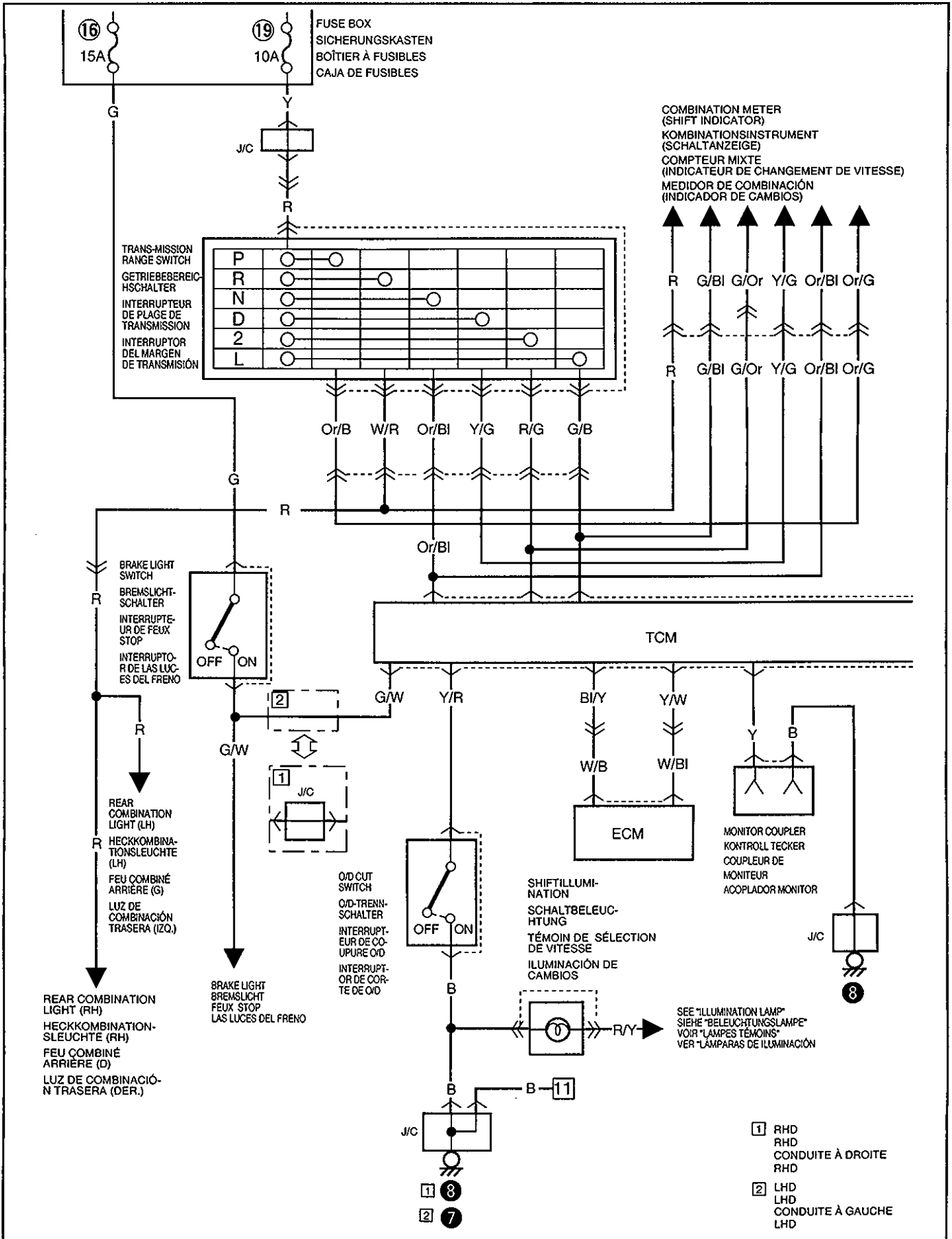

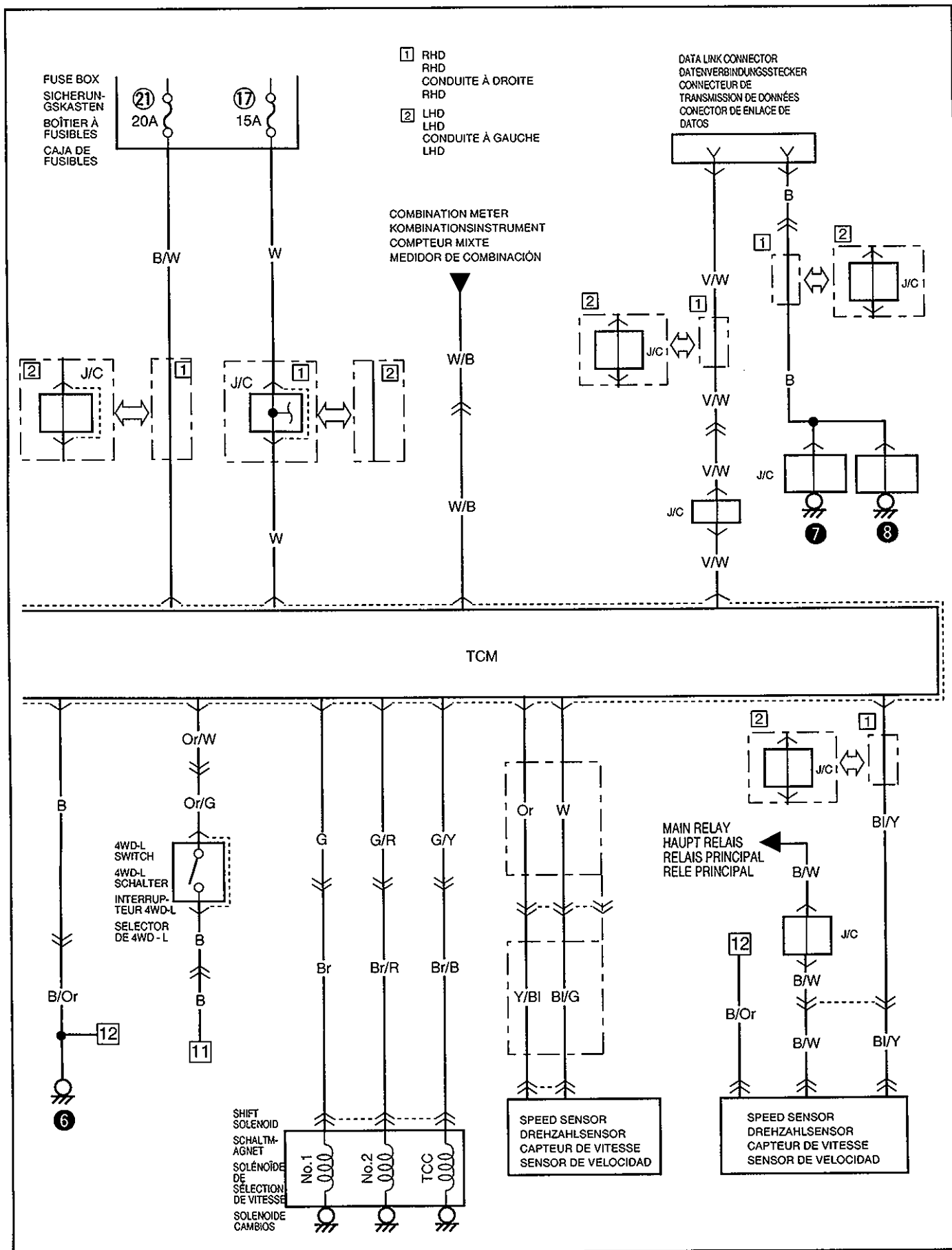

**4WD CONTROL SYSTEM**  
**4WD STEUERSYSTEM**  
**SYSTEME DE COMMANDE 4WD**  
**SISTEMA DE CONTROL DE TRACCIÓN EN LAS CUATRO RUEDAS**

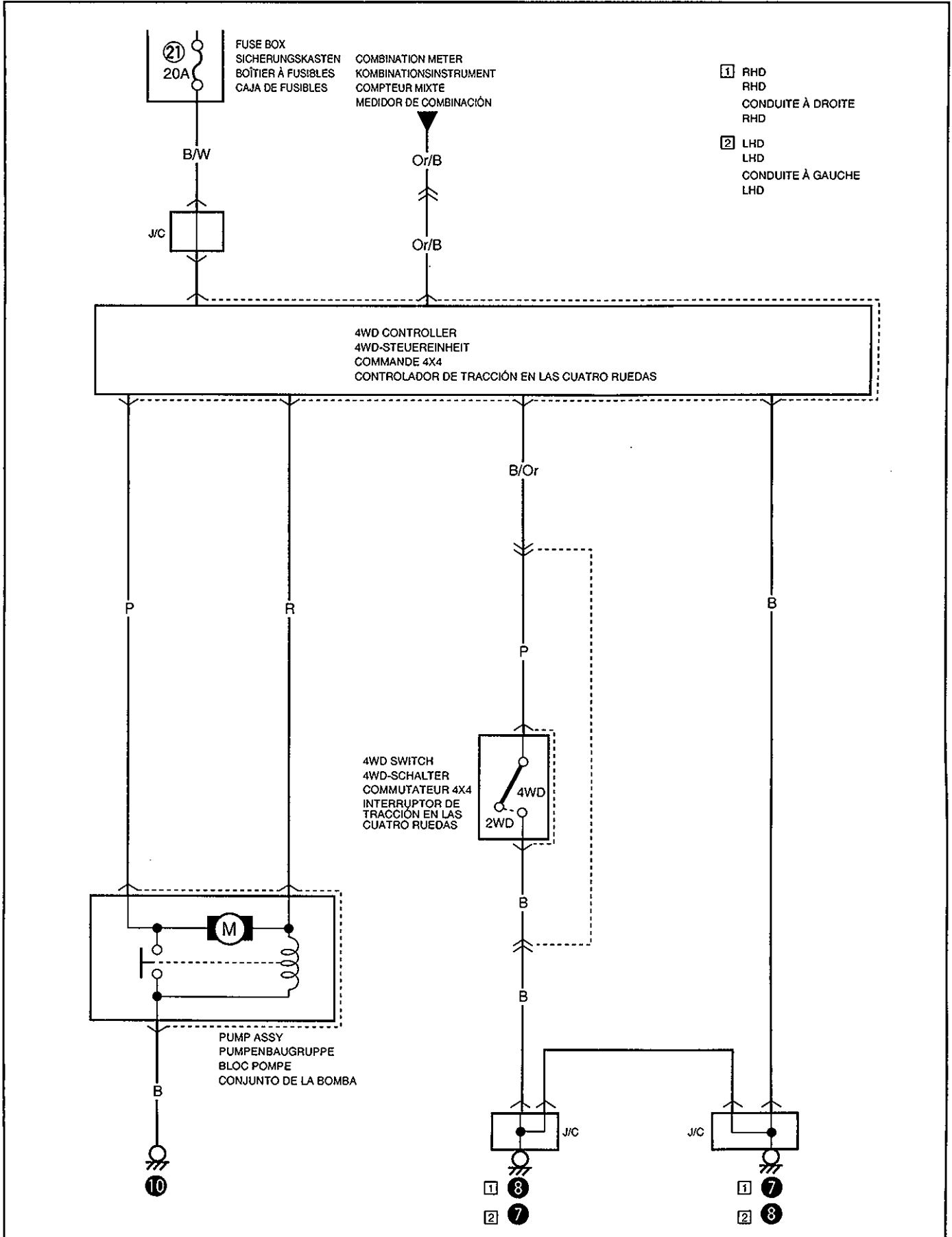





INDICATOR LAMP  
KONTROLLEUCHTE  
INDICATEURS TÉMOINS  
LÁMPARAS INDICADORAS

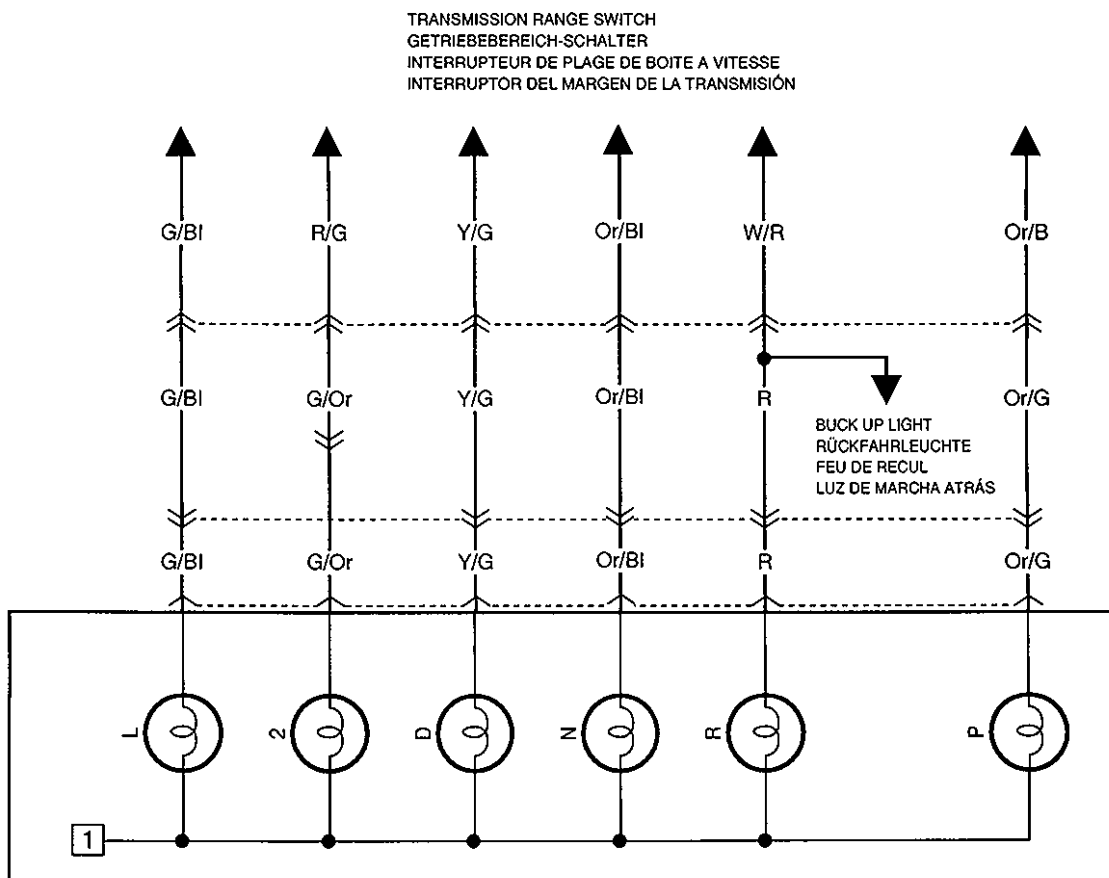

**WARNING LAMP**  
**WARNLEUCHTE**  
**TÉMOINS D'AVERTISSEMENT**  
**LÁMPARA DE ADVERTENCIA**

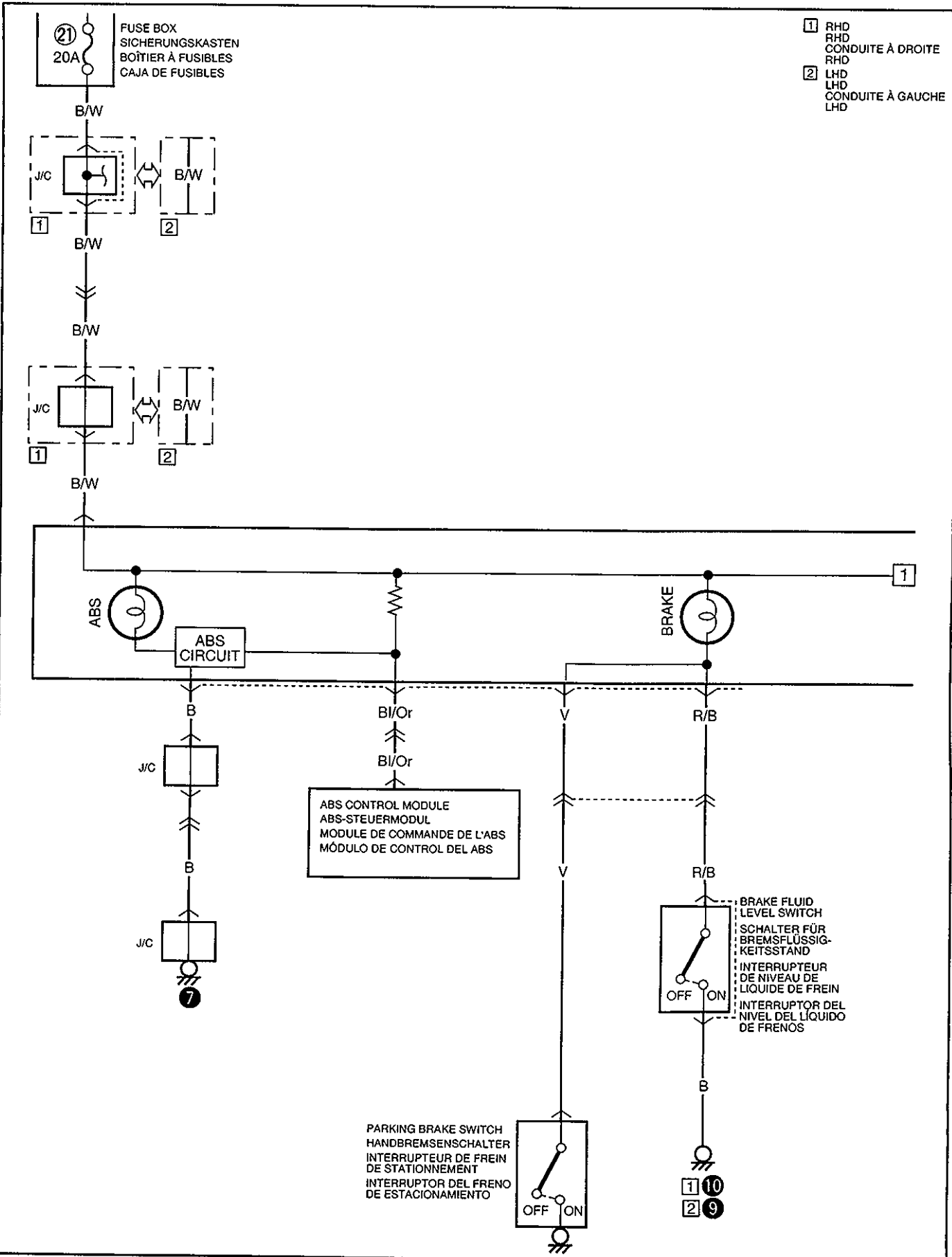

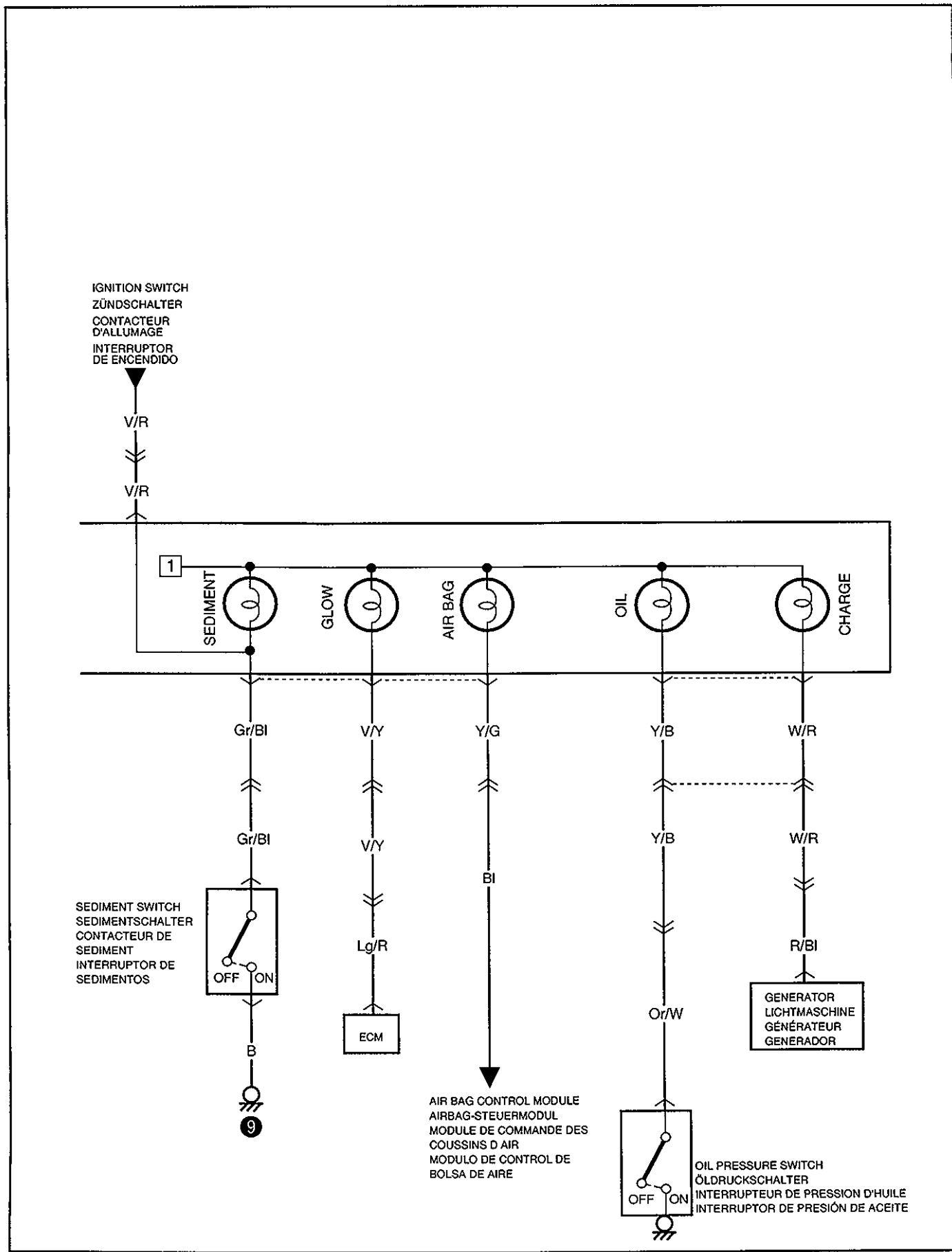

**HEADLIGHT SYSTEM**  
**SCHEINWERFERANLAGE**  
**SYSTÈME DES PHARES**  
**SISTEMA DE LOS FAROS**

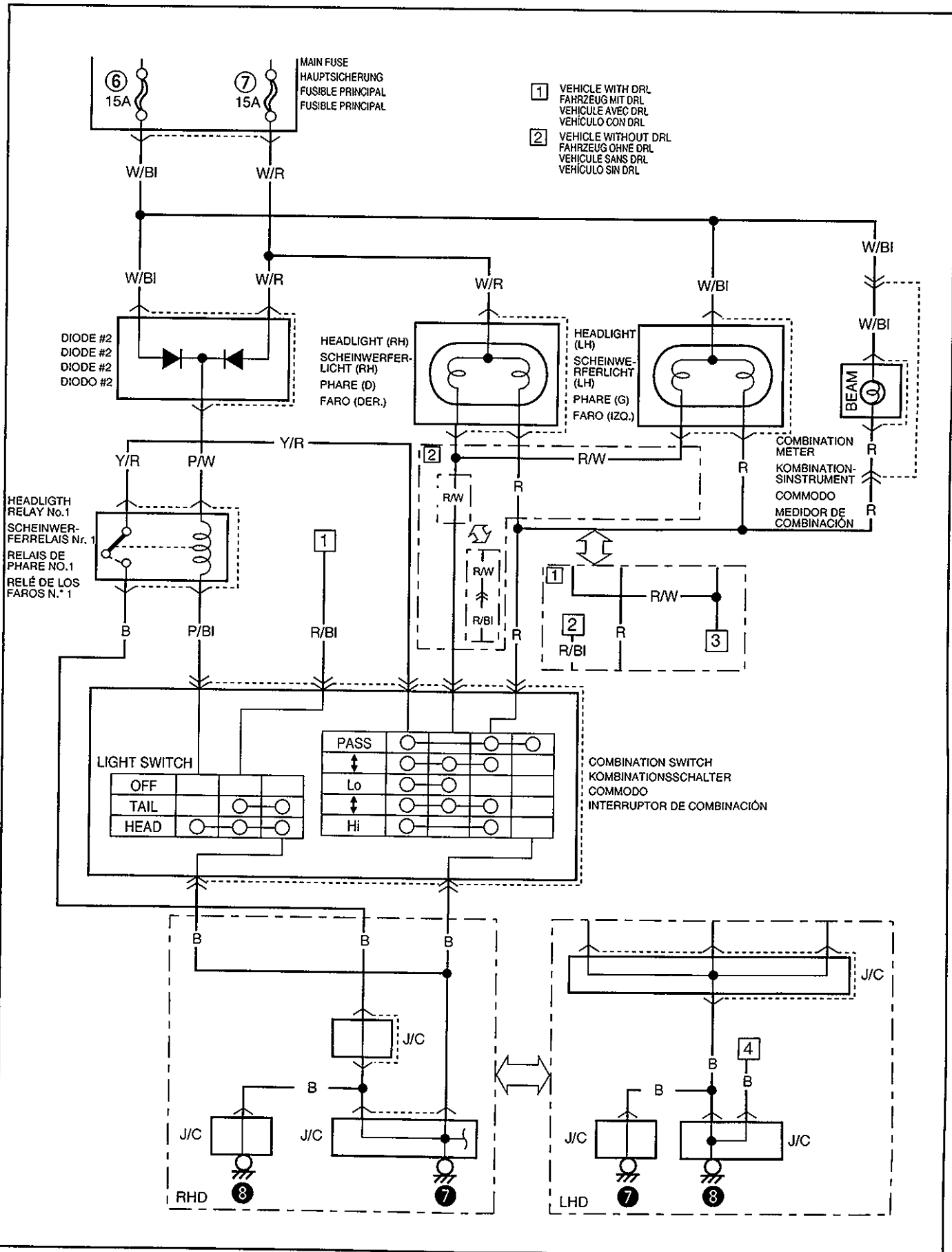

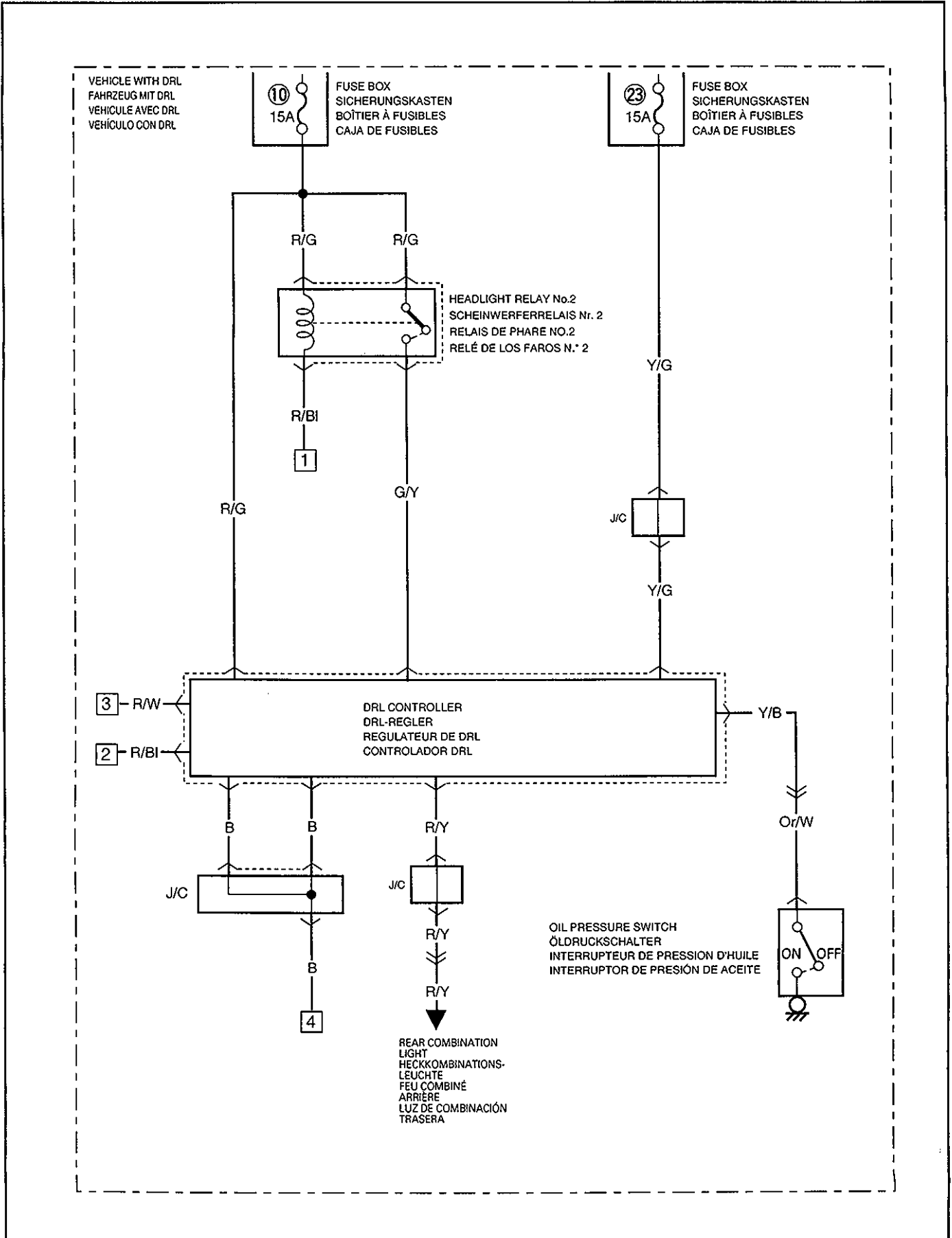

**ILLUMINATION LAMP (RIGHT HAND STEERING VEHICLE)**

**BELEUCHUNGSLAMPE (FAHRZEUG MIT RECHTSLENKUNG)**

**LAMPES TÉMOINS (VEHICULE A CONDUITE A DROITE)**

**LÁMPARAS DE ILUMINACIÓN (VEHÍCULO CON DIRECCIÓN A LA DERECHA)**

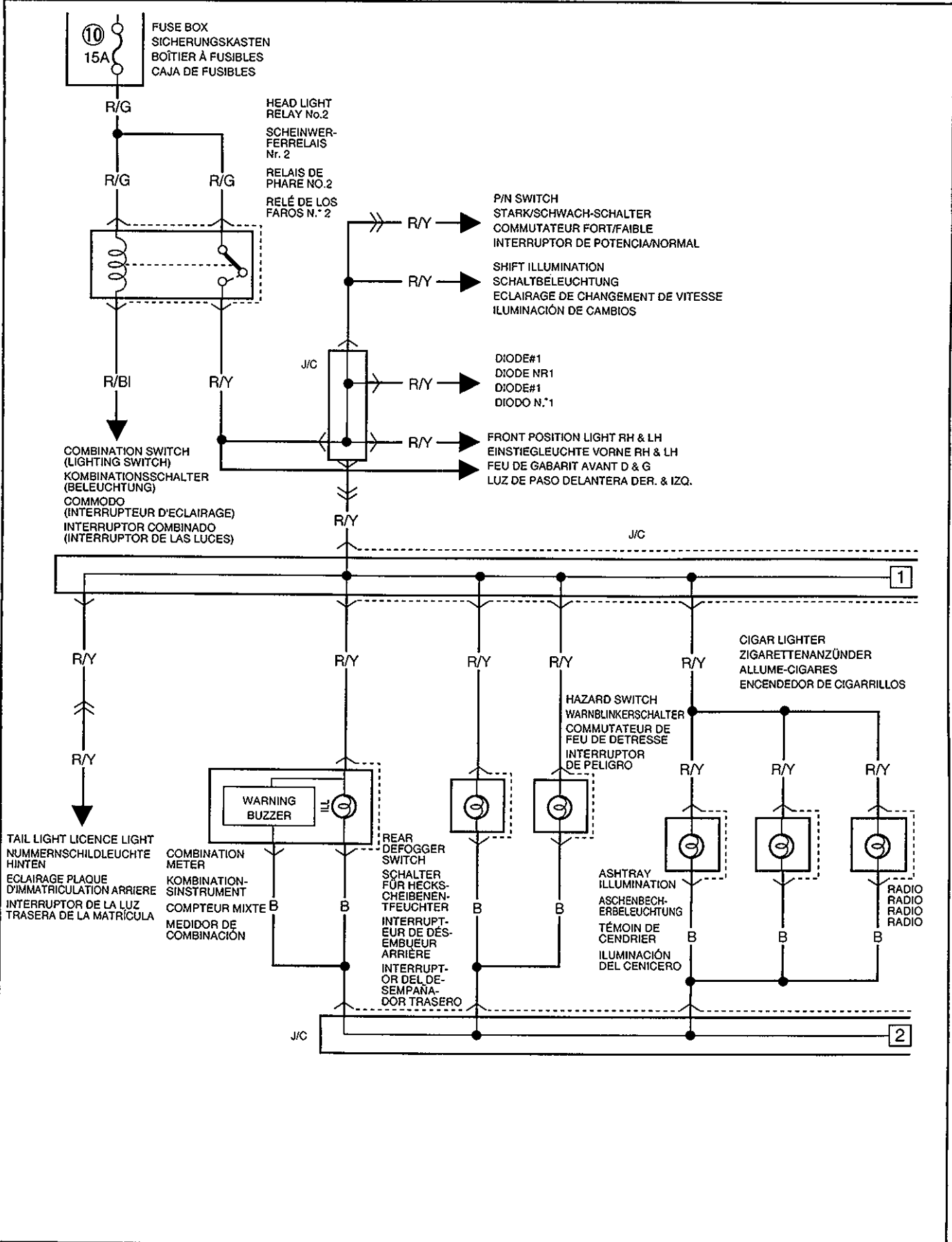

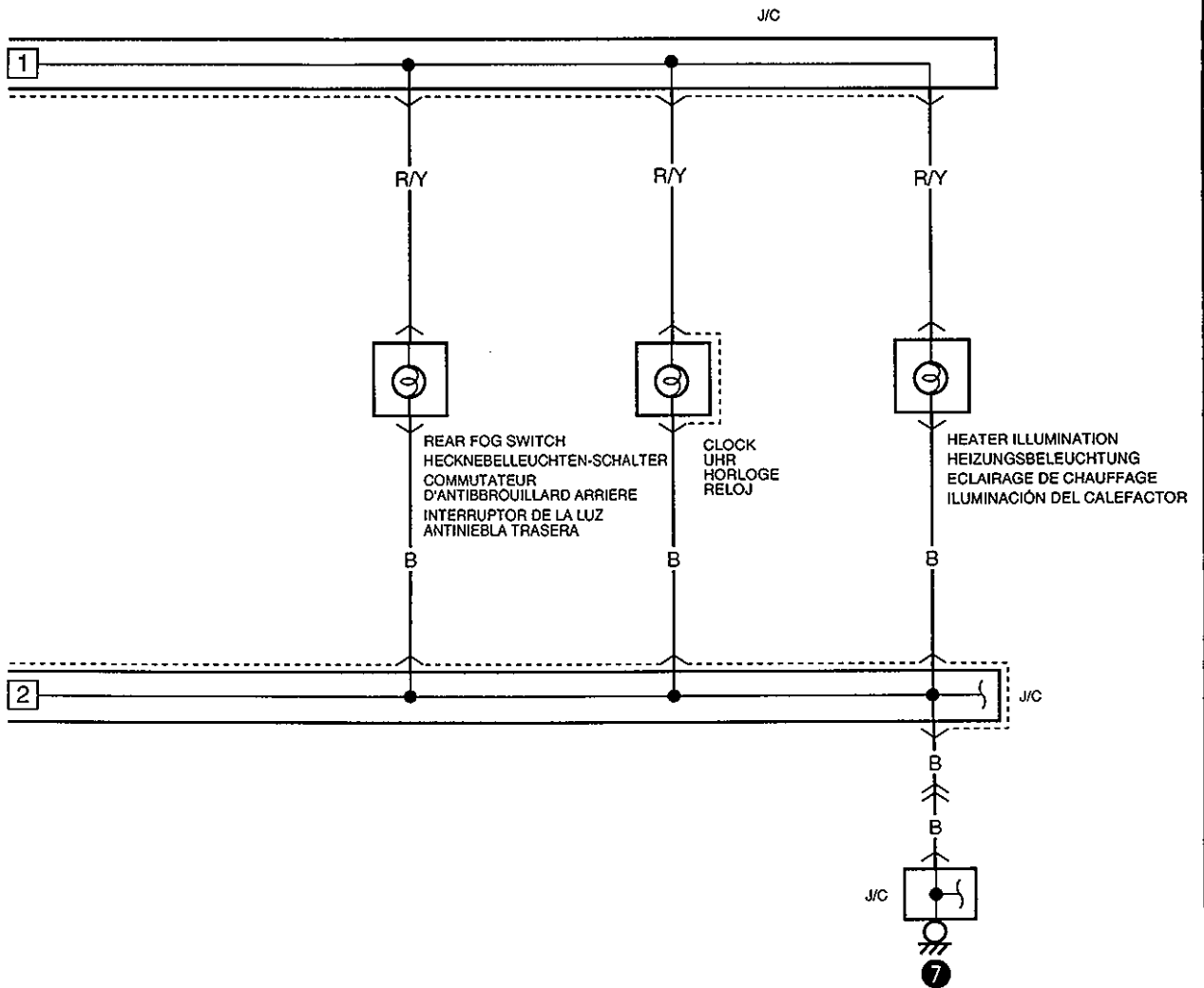

**ILLUMINATION LAMP (LEFT HAND STEERING VEHICLE)**  
**BELEUCHUNGSLAMPE (FAHRZEUG MIT LINKSLENKUNG)**  
**LAMPES TÉMOINS (VEHICULE A CONDUITE A GAUCHE)**  
**LÁMPARAS DE ILUMINACIÓN (VEHÍCULO CON DIRECCIÓN A LA IZQUIERDA)**

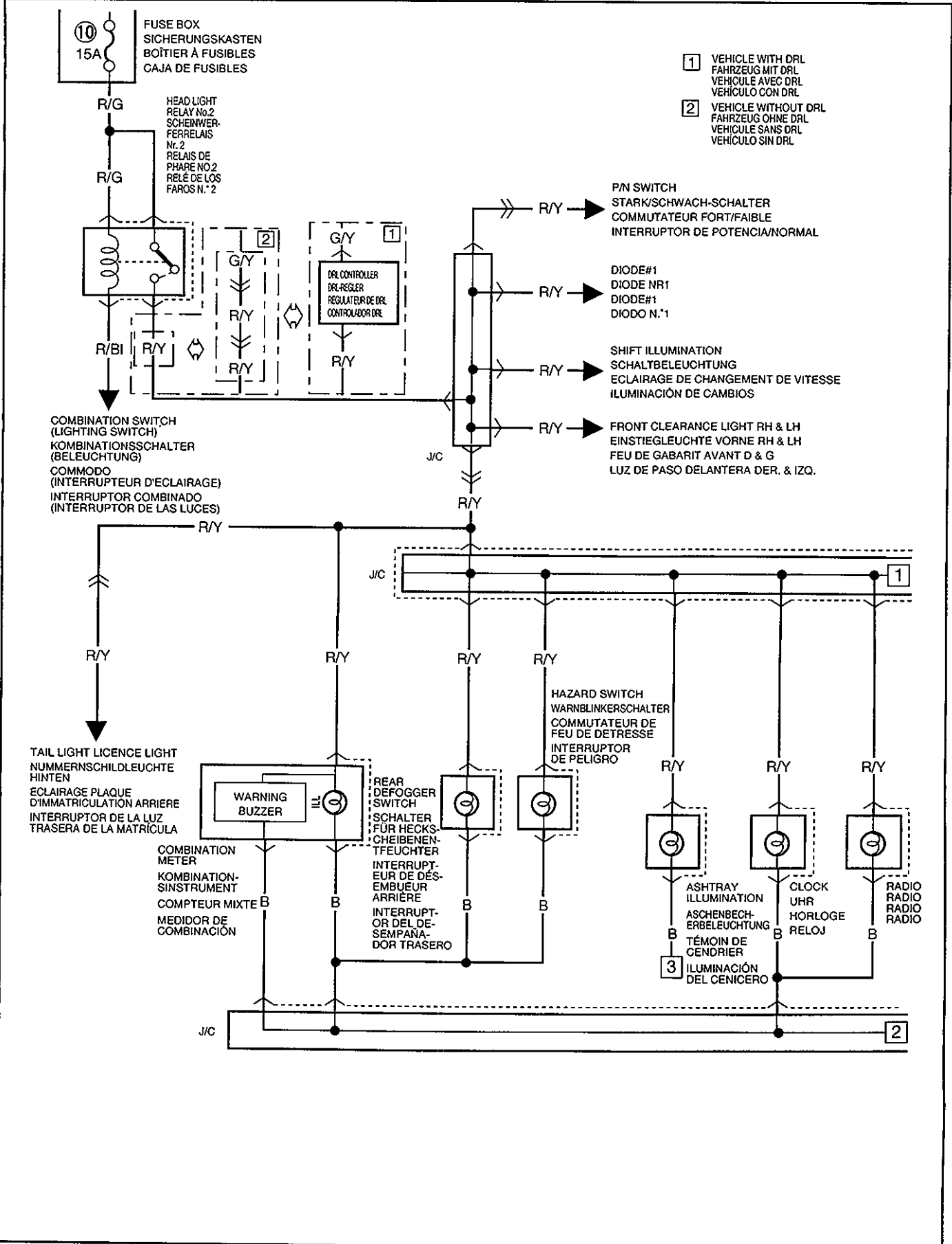

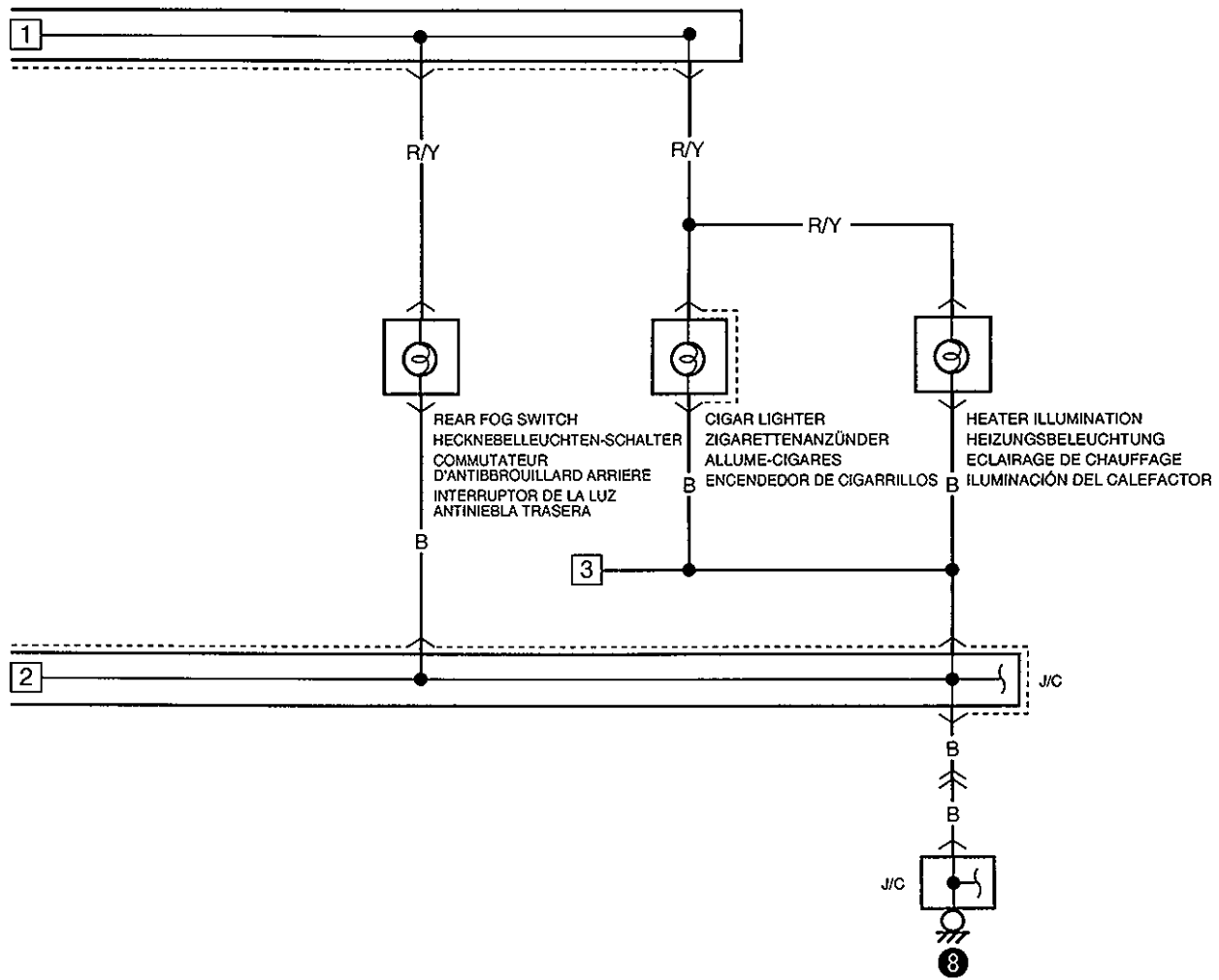

**BACK-UP LIGHT**  
**RÜCKFAHRLEUCHE**  
**FEUX DE MARCHE ARRIÈRE**  
**LUZ DE MARCHA ATRÁS**

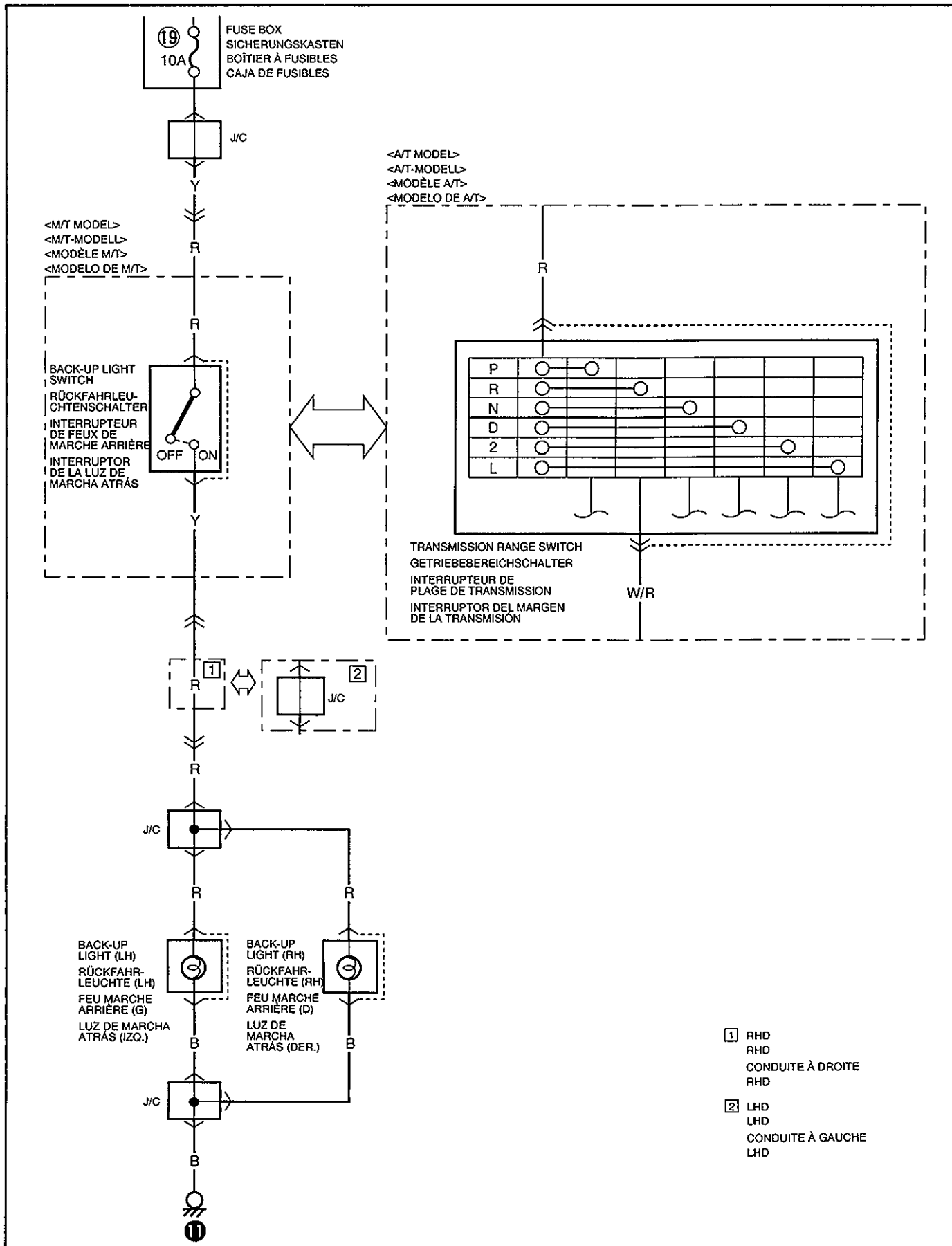

MEMO  
NOTIZEN  
NOTE  
NOTAS

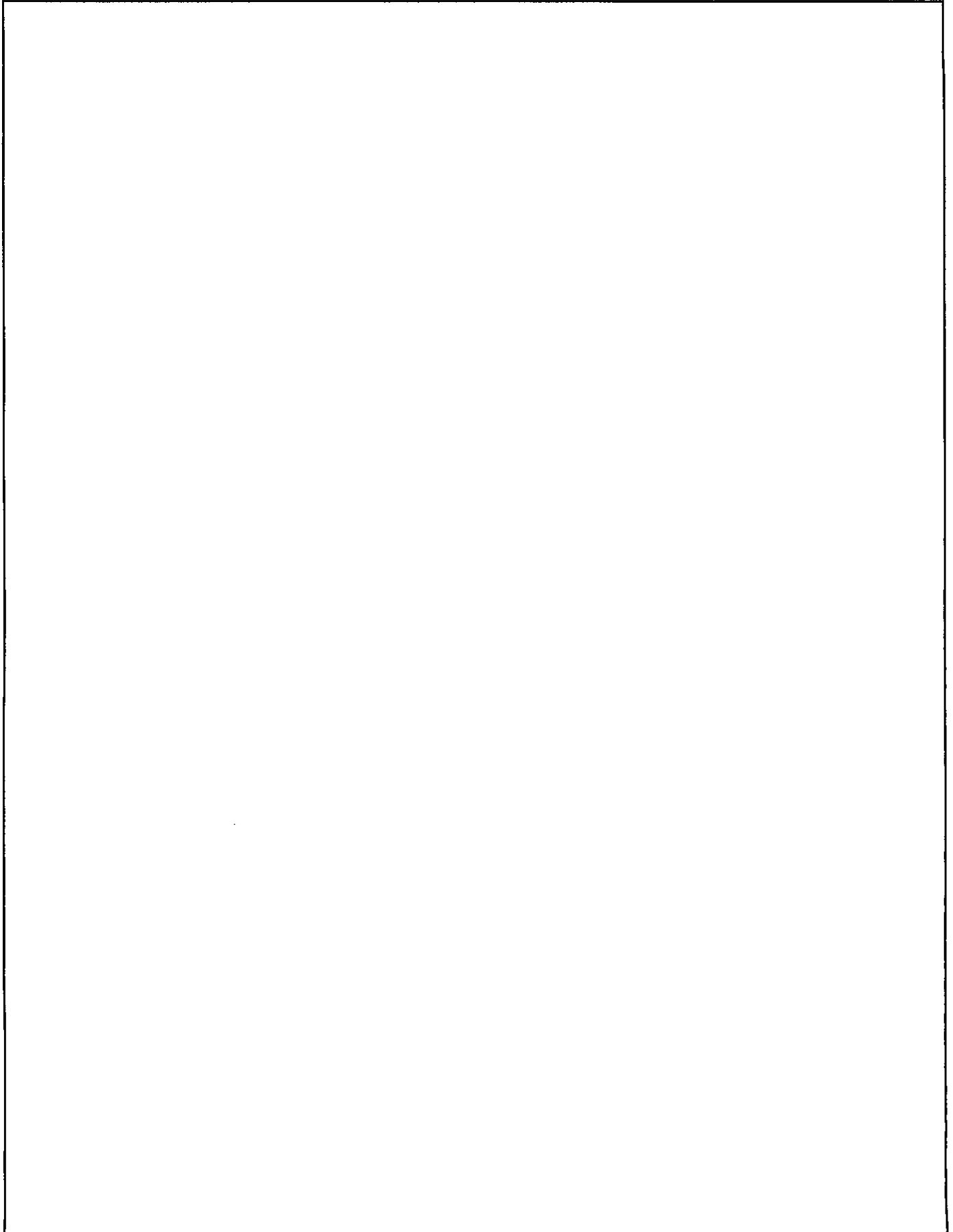

**HEATER AND AIR CONDITIONING**

**HEIZUNG UND KLIMAANLAGE**

**CHAUFFAGE ET CLIMATISATION**

**CALEFACTOR Y ACONDICIONADOR DE AIRE**

- 1 RHD  
RHD  
CONDUITE À DROITE  
RHD
- 2 LHD  
LHD  
CONDUITE À GAUCHE  
LHD

MODE ACTUATOR  
MODUS-STELLGLIED  
COMMANDE DE MODE  
ACTUADOR DE MODO

ACTUATING CIRCUIT  
REGELSCHALTUNG  
CIRCUIT DE COMMANDE  
CIRCUITO DE ACTUACIÓN

SEE "ILLUMINATION LAMP"  
SIEHE "BELEUCHTUNGSLAMPE"  
VOIR "LAMPES TÉMOINS"  
VER "LAMPARAS DE ILUMINACIÓN"

MODE CONTROL SWITCH  
MODUS-REGELSCHALTER  
INTERRUPTEUR DE COMMANDE DE MODE  
INTERRUPTOR DE CONTROL DE MODO

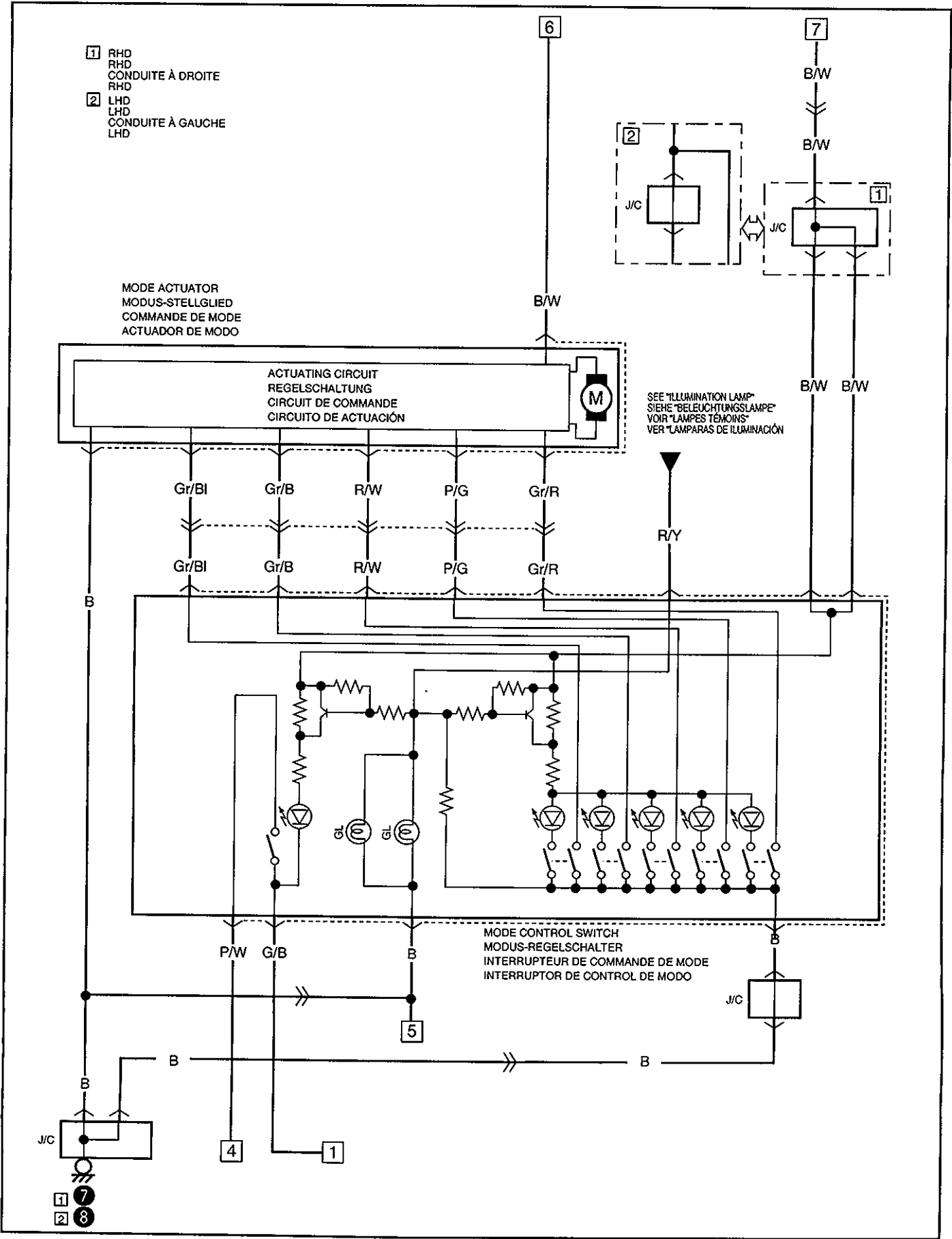

- 1 7
- 2 8

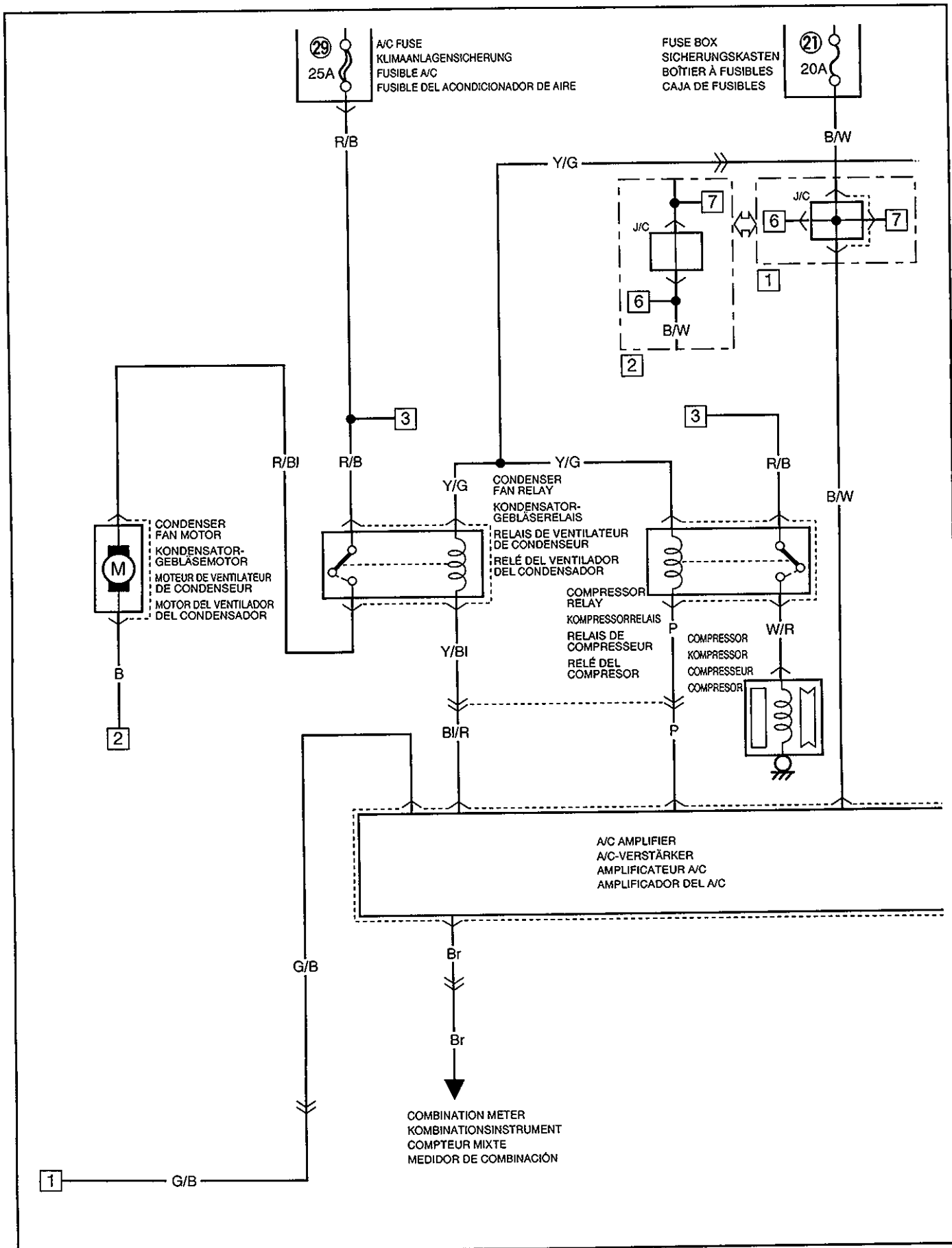

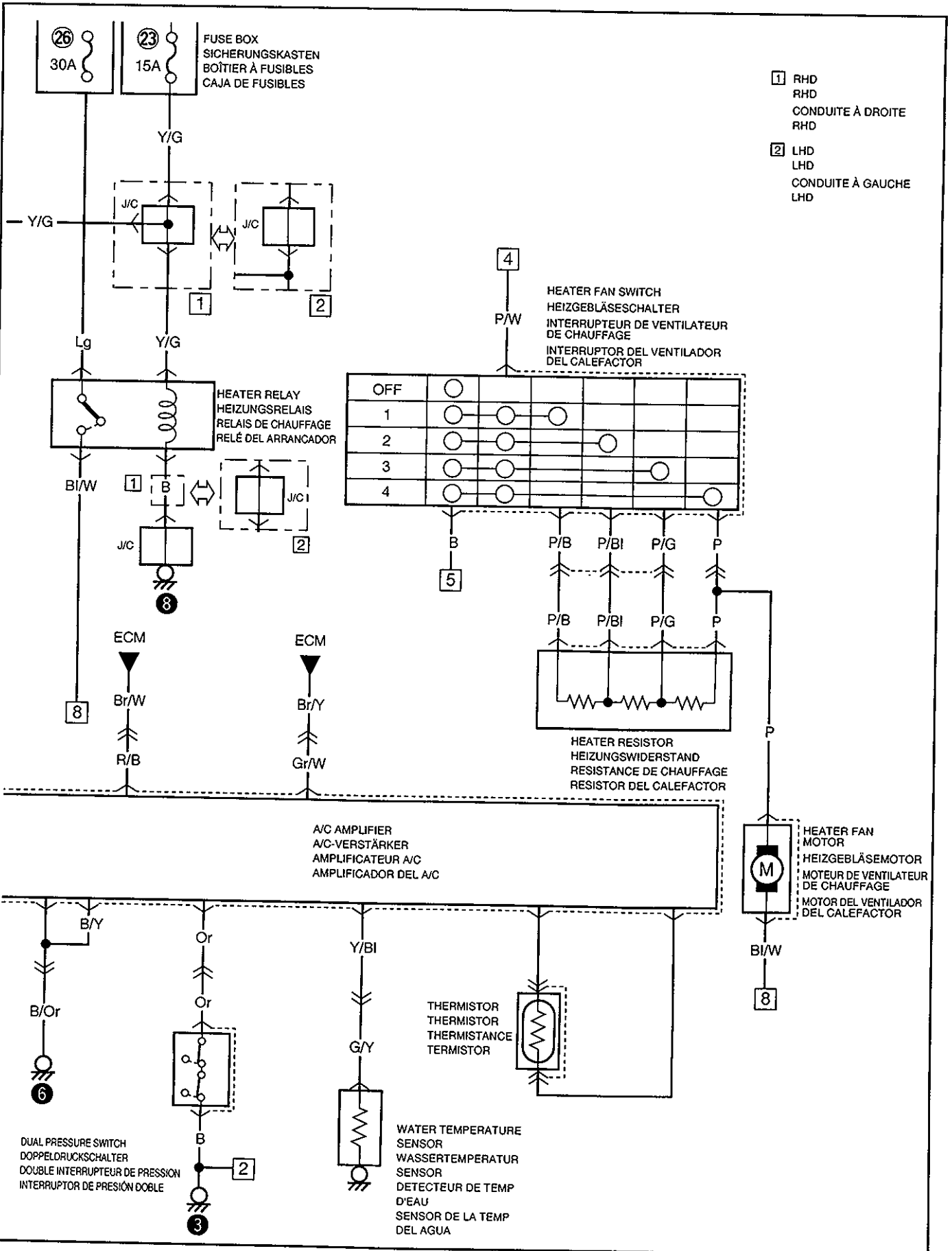

MEMO  
NOTIZEN  
NOTE  
NOTAS

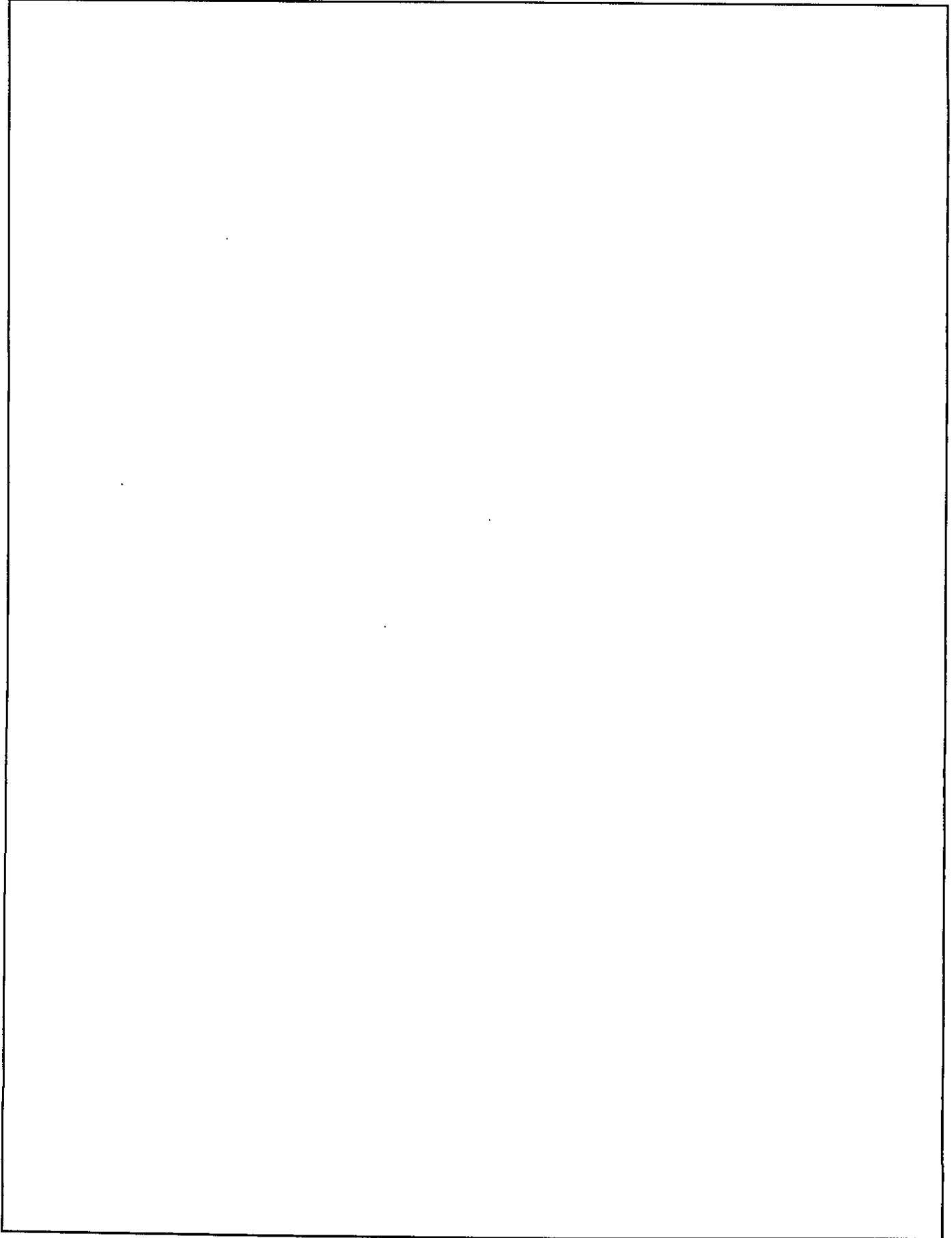

**ANTI-LOCK BRAKE SYSTEM**  
**ANTIBLOCKIERSYSTEM**  
**SYSTÈME D'ANTIBLOCAGE DES FREINS**  
**SISTEMA DE FRENOS ANTIENCLAVAMIENTO**

- 1 RHD  
RHD  
CONDUITE À DROITE  
RHD
- 2 LHD  
LHD  
CONDUITE À GAUCHE  
LHD

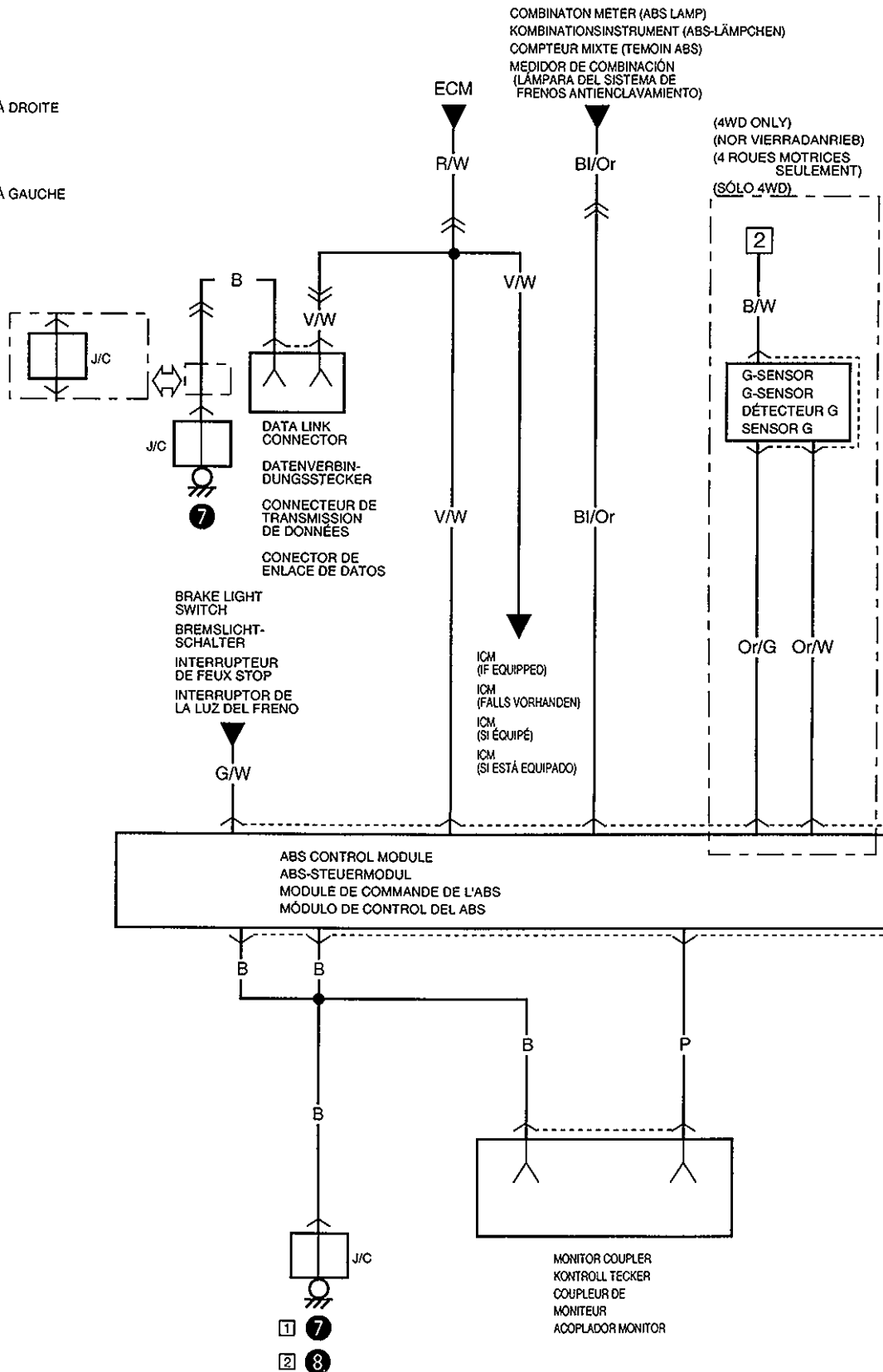

- 1 7
- 2 8

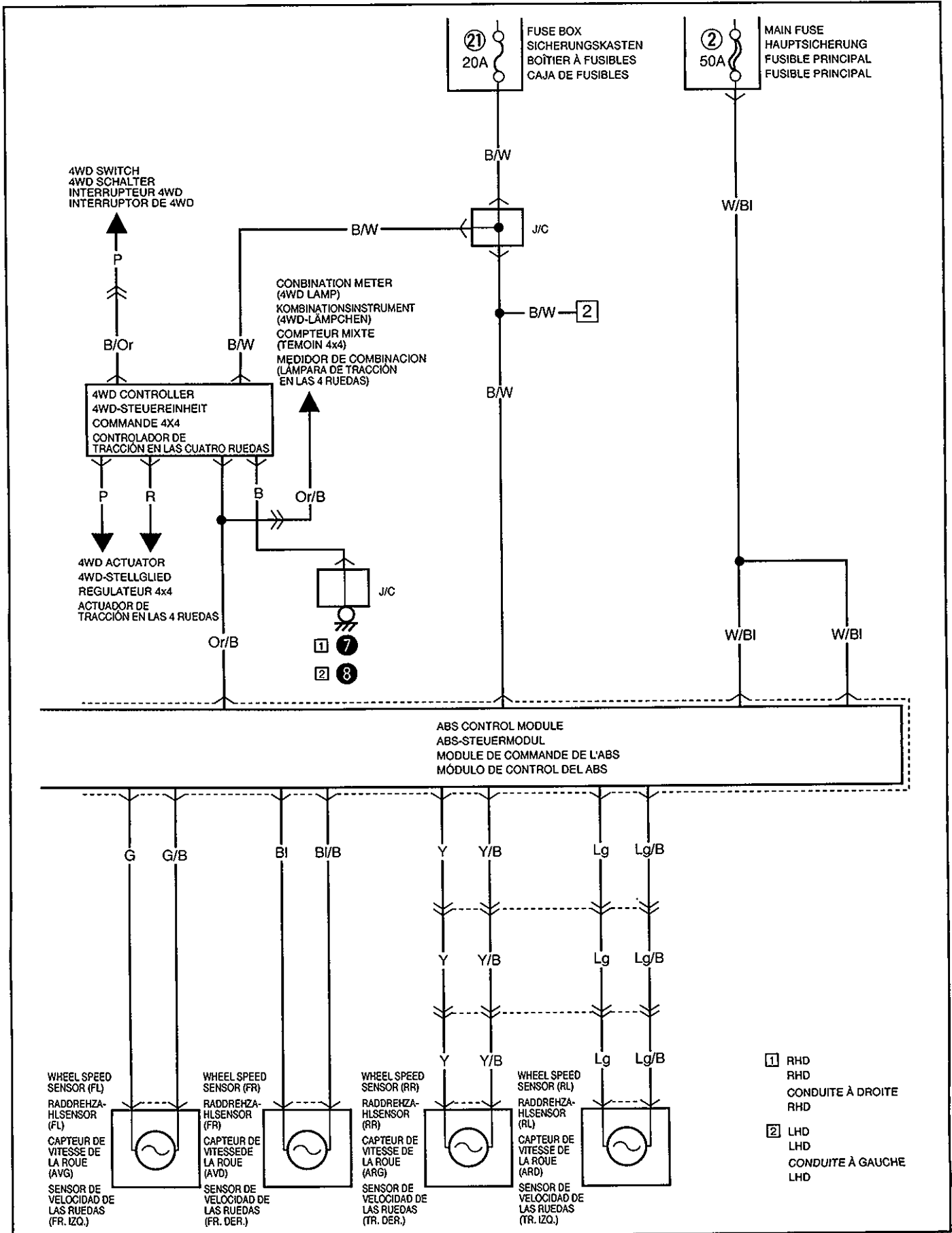

Prepared by  
**SUZUKI MOTOR CORPORATION**

Overseas Service Department

1st Ed. July, 1998

Printed in Japan

Printing: July, 1998

295